

BEFCO®

Operator's Manual

TORNADO

Medium Duty Rotary Cutter

RMD-360, RMD-372

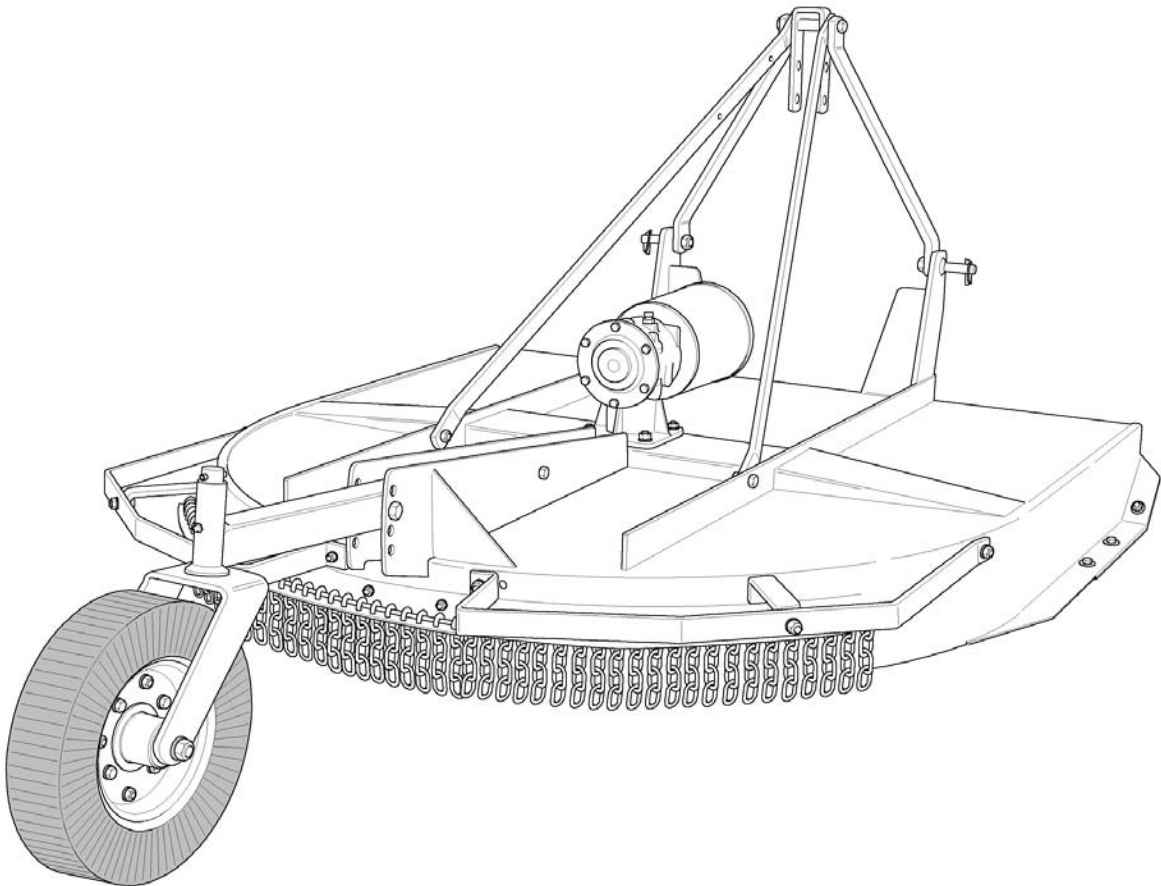

The operator's manual is a technical service guide and must always accompany the machine.

Manual 971-396B

June 2020

SAFETY

Take note! This safety alert symbol found throughout this manual is used to call your attention to instructions involving your personal safety and the safety of others. Failure to follow these instructions can result in injury or death.



*This symbol means:
ATTENTION!
BECOME ALERT!
YOUR SAFETY IS INVOLVED!*

Signal Words

Note the use of the signal words DANGER, WARNING and CAUTION with the safety messages. The appropriate signal words for each have been selected using the following guidelines:



DANGER: Indicates an imminently hazardous situation that, if not avoided, will result in death or serious injury.



WARNING: Indicates a potentially hazardous situation that, if not avoided, could result in death or serious injury, and includes hazards that are exposed when guards are removed. It may also be used to alert against unsafe practices.



CAUTION: Indicates a potentially hazardous situation that, if not avoided, may result in minor or moderate injury.

INDEX

1 - GENERAL INFORMATION	4
1.01 - General	4
1.02 - Warranty Information	4
1.03 - Model and Serial Number ID	5
2 - SAFETY PRECAUTIONS	6
2.01 - Preparation	6
2.02 - Starting and Stopping	7
2.03 - Messages and Signs	7
3 - OPERATION	10
3.01 - Operational Safety	10
3.02 - Setup	12
3.03 - Assembly Instructions	12
3.04 - Cutting Height Adjustment	13
3.05 - Pre-Operational Check	14
3.06 - Attaching to the Tractor	15
3.07 - Start Up	16
3.08 - Working Speed	17
3.09 - Uneven Terrain	18
3.10 - Removing Rotary Cutter from the Tractor	18
3.11 - Transport	18
4 - MAINTENANCE	20
4.01 - Maintenance Safety	20
4.02 - Service	21
4.03 - Blade Maintenance	23
4.04 - Rotor & Stump Jumper Assembly	24
4.05 - Driveline	25
4.06 - Safety Slip Clutch	27
5 - REPAIR PROCEDURES	29
5.01 - Gearbox	29
5.02 - Suggested Spare Parts	29
5.03 - Storage	29
6 - TROUBLESHOOTING	31
7 - PRE-DELIVERY CHECKLIST	32
8 - WARRANTY	33
PARTS MANUAL	37

1 - GENERAL INFORMATION

Thank you and congratulations for having chosen our implement. Your new rotary cutter is a technologically advanced machine constructed of high quality, sturdy components that will fulfill your working expectations. Read this manual carefully. It will instruct you on how to operate and service your mower safely and correctly. Failure to do so could result in personal injury and/or in equipment damage.

1.01 - General

The implement described in this manual is to be used with tractors with PTO at 540 rpm and clockwise rotation.



CAUTION: Always ensure that the coupling of the implement with the tractor is done at the same PTO speed and direction of rotation. Do not operate this implement at a PTO speed or direction of rotation other than that shown on the implement. Serious damage can occur to the machine and/or the operator.



CAUTION: Unless otherwise specified, all hardware is metric. Use only metric tools on metric hardware. Other tools that do not fit properly can slip and cause injury.



CAUTION: Right hand and left hand sides of the implement are determined by facing in the direction the implement will travel when going forward (see fig. 2).

1.02 - Warranty Information

Carefully read the Warranty section¹, detailing coverage and limitations of this warranty. **Warranty** is provided for customers who operate and maintain their equipment as described in this manual. Warranty registration is accomplished by the dealer by completing and forwarding the **Warranty Registration** form to the Company, along with a copy of the dealer's invoice. It is in your best interest to insure that this has been done.

Warranty does not cover the following:

1. Cleaning, transporting, mailing and service call charges.

¹ See Chapter 8 - Warranty.

2. Normal wear items such as blades, bearings, wheels, drivelines, shear pins, slip clutches, etc.
3. Depreciation or damage caused by normal wear, accidents, improper maintenance, improper protection or improper use.
4. The use of non-original spare parts and accessories.

Your Authorized Company Dealer has genuine parts in stock. Only these approved replacement parts should be used.

This limited warranty covers defective material and workmanship. The cost of normal maintenance or repairs for accidents or improper use and related labor will be borne by the owner.

1.03 - Model and Serial Number ID

Attached to the frame is an ID plate showing the model and the serial number. Record your implement model and serial number in the space provided below. Your dealer needs this information to give you prompt, efficient service when you order parts.

BEFCO	1781 S. Wesleyan Blvd. – P.O. Box 6036 Rocky Mount, N.C. 27802 – U.S.A. Tel: 1.252.977.9920 Fax: 1.252.977.9718
MODEL:	
SERIAL:	
VERSION:	

2 - SAFETY PRECAUTIONS

Safety is the primary concern in the design and manufacture of our products. Unfortunately our efforts to provide safe equipment can be wiped out by a single careless act of an operator.

In addition to the design and configuration of equipment, hazard control and accident prevention are dependent upon the awareness, concern, prudence and proper training of personnel involved in the operation, transport, maintenance and storage of equipment. It is the operator's responsibility to read and understand all safety and operating instructions in the manual and to follow these.

Allow only properly trained personnel to operate the mower. Working with unfamiliar equipment can lead to careless injuries. Read this manual, and the manual for your tractor, before assembly or operation, to acquaint yourself with the machines. It is the mower owner's responsibility, if this machine is used by any person other than yourself, is loaned or rented, to make certain that the operator, prior to operating, reads and understands the operator's manuals and is instructed in safe and proper use.



WARNING: Because of possible injury from thrown objects, all rotary cutters are potentially dangerous. Any rotary cutter intended for use along roadways or other locations where people may be present, must be used with safety shields in place.

2.01 - Preparation



1. Before operating equipment read and understand the operator's manual and the safety signs (**see fig. 2**).
2. Thoroughly inspect the implement before initial operation to assure that all packaging materials, i.e. wires, bands, and tape have been removed. Ensure that tape has been removed from blades prior to use.
3. Personal protection equipment including hard hat, safety glasses, safety shoes, and gloves are recommended during assembly, installation, operation, adjustment, maintaining and/or repairing the implement.
4. Operate the rotary cutter only with a tractor equipped with an approved Roll-Over-Protective-System (ROPS). Always wear your seat belt. Serious injury or even death could result from falling off the tractor.
5. Clear area to be cut of stones, branches or other debris that might be thrown, causing injury or damage.
6. Operate only in daylight or good artificial light.
7. Ensure rotary cutter is properly mounted, adjusted and in good operating condition.

8. Ensure that all safety shielding and safety signs are properly installed and in good condition.

2.02 - Starting and Stopping



1. Be sure that no one is near the machine prior to engaging or while the machine is working.
2. Be sure the tractor is in "Neutral" before starting engine.
3. Mower operating power is supplied from tractor PTO. Refer to your tractor manual for PTO engagement and disengagement instructions. Always operate PTO at 540 rpm. Know how to stop the tractor and mower quickly in case of an emergency.
4. When engaging PTO, the engine rpm should always be low. Once engaged and ready to start cutting, raise PTO speed to 540 rpm and maintain throughout cutting operation.
5. Check the tractor master shield over the PTO stub shaft. Make sure it is in good condition and fastened securely to the tractor. Purchase a new shield if old shield is damaged or missing.
6. Ensure that the shield provided for the driveline's slip clutch is properly mounted to the gearbox and in good condition.
7. After striking an obstacle, disengage the PTO, shut the tractor down and thoroughly inspect for damage before restarting.
8. Never engage the PTO until the cutter is in the down position and resting on the ground. Never raise the cutter until all blades have come to a complete stop.
9. To park the vehicle safely, stop vehicle on a level surface (not on a slope), disengage PTO, engage the parking brake, stop the engine, remove the key, and wait for engine and all moving parts to stop before leaving the operator's seat.
10. Stay clear of rotating drivelines. Entanglement in rotating driveline can cause serious injury or death. Wear close fitting clothing. Stop the engine and be sure PTO driveline is stopped before getting near it.

2.03 - Messages and Signs



1. Read and adhere to all safety and operating decals on this machine (**see fig. 2**).
2. Before dismounting tractor: Allow moving parts to stop, stop engine, set brake and remove the key of unattended equipment.
3. Keep away from rotating blades and driveline.
4. Keep guards and shields in place and in good condition.
5. Do not mow with bystanders in area.
6. Allow no riders on tractor or mower.
7. Allow moving parts to stop before repair.

8. Securely support cutter before working underneath.

Additional warning and operating decals are available at no extra charge. Please specify model and serial number when ordering.

Fig. 2 - Safety decals - implement; replace immediately if damaged.

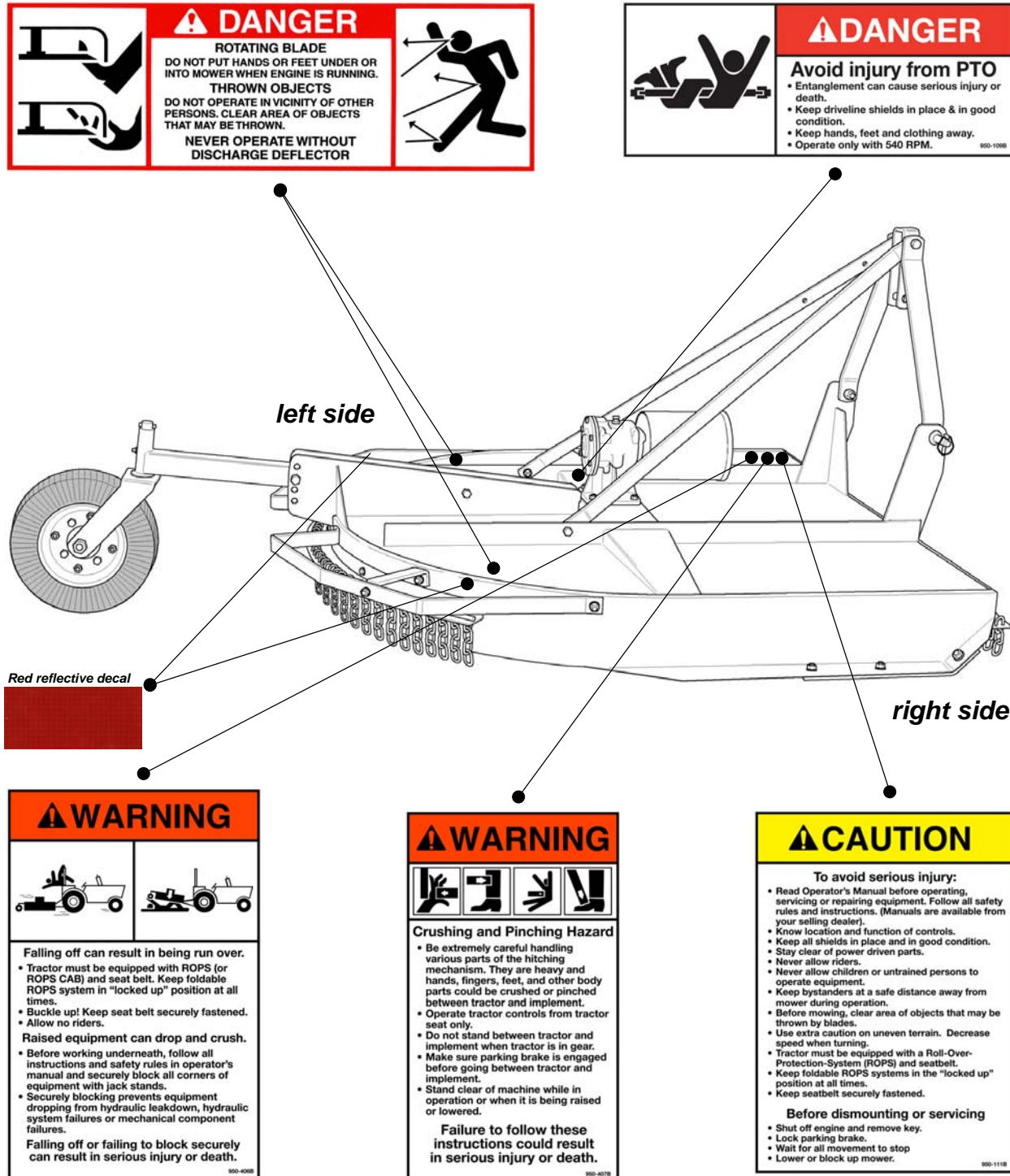

Safety decals - driveline; replace immediately if damaged.

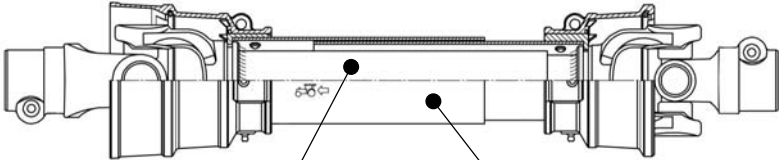

placed on outer tube



placed on outer shield

3 - OPERATION

You have purchased a rotary cutter which is solid, dependable, and built to last. Our rotary cutters are ideal for use in farms, industrial sites, airports, highways, hospital grounds and many other applications. The Tornado RMD handles the tallest grass and toughest mowing assignments; including light bushes with limbs of up to 2" in diameter. It can also be used for chopping wheat, cornstalks, sunflowers, artichokes and potatoes. The residue is pulverized for easy incorporation into the ground.

On the rotary cutter, the tractor PTO transmits its power through a driveline to a speed multiplier gearbox. The pinion gear shaft of the gearbox transmits the power to the blades holder always protected by a stump guard.

The Tornado RMD rotary cutters, for tractors up to 80 HP, are medium duty models with working widths of 60" and 72". The PTO runs at 540 rpm and the rotor turns at 855 rpm. The blades tip speed is 13,189 ft/min. on the 60" and 15,748 ft/min. on the 72".

The cutter is equipped with a heavy duty gearbox and an 8 gauge deck. The balanced rotor is equipped with 2, 4"x½" free swing spring steel blades. The implement comes with a cutting height control tail wheel and with a 4"x8"x15" laminated tire with tapered roller bearings. The cutting height varies from 1" to 9¼". The machine comes with a standard stump jumper to protect the blade holder rotor. The driveline is equipped with a multidisk slip clutch.

3.01 - Operational Safety



CAUTION: Our rotary cutters are designed considering safety as the most important aspect and are the safest available in today's market. Unfortunately, human carelessness can override the safety features built into our machines. Injury prevention and work safety, aside from the features on our cutters, are very much due to the responsible use of the equipment. It must always be operated prudently following with great care, the safety instructions laid out in this manual.



WARNING: Because of possible injury from thrown objects, all rotary cutters are potentially dangerous. Any rotary cutter intended for use along roadways or other locations where people may be present, must be used with safety shields in place.



1. The use of this equipment is subject to certain hazards which cannot be prevented by mechanical means or product design. All operators of this equipment must read

- and understand this entire manual, paying particular attention to safety and operating instructions, prior to using.
2. Do not operate the tractor and rotary cutter when you are tired, sick or when using medication.
 3. Keep all helpers and bystanders at least 300 feet from a rotary cutter. Only properly trained people should operate this machine.
 4. When this machine is operated in populated areas where thrown objects could injure persons or property, front and rear safety shields (which come standard on our rotary cutter and are designed to reduce the possibility of thrown objects) must be installed.
 5. The majority of accidents involve entanglements on the driveline, injury of bystanders by objects thrown by the rotating blades, and operators being knocked off the tractor by low hanging limbs and then being run over by the rotary cutter. Accidents are most likely to occur with machines that are loaned or rented to someone who has not read the operator's manual and is not familiar with a rotary cutter.
 6. Always stop the tractor, set brake, shut off the tractor engine, remove the ignition key, lower implement to the ground and allow rotary cutter blades to come to a complete stop before dismounting tractor. Never leave equipment unattended with the tractor running.
 7. Never place hands or feet under rotary cutter with tractor engine running or before you are sure all motion has stopped. Stay clear of all moving parts.
 8. Do not allow riders on the rotary cutter or tractor at any time. There is no safe place for riders.
 9. Do not operate unless all personnel, livestock and pets are at least 300 feet away to prevent injury by thrown objects.
 10. Before backing up, disengage the rotary cutter and look behind carefully.
 11. Install and secure all guards and shields before starting or operating.
 12. Keep hands, feet, hair and clothing away from moving parts.
 13. This rotary cutter is designed for use only on tractors with 540 rpm power take off.
 14. Never operate tractor and rotary cutter under trees with low hanging limbs. Operators can be knocked off the tractor and then run over by the rotating blades.
 15. The rotating parts of this machine have been designed and tested for rugged use. However, they could fail upon impact with heavy, solid objects such as steel guard rails and concrete abutments. Such impact could cause the broken objects to be thrown outward at very high velocities. To reduce the possibility of property damage, serious injury, or even death, never allow the cutting blades to contact such obstacles.
 16. Frequently check rotary cutter blades. They should be sharp, free of nicks and cracks and securely fastened.
 17. Stop rotary cutter immediately upon striking an obstruction. Turn engine off, remove key, inspect and repair any damage before resuming operation.
 18. Stay alert for holes, rocks and roots in the terrain and other hidden hazards. Keep away from drop-offs.

19. Use extreme care and maintain minimum ground speed when transporting on hillside, over rough ground and when operating close to ditches or fences. Be careful when turning sharp corners.
20. Reduce speed on slopes and sharp turns to minimize tipping or loss of control. Be careful when changing directions on slopes. Do not start or stop suddenly on slopes. Avoid operation on steep slopes.
21. When using a unit, a minimum 20% of tractor and equipment weight must be on tractor front wheels. Without this weight, tractor could tip over, causing personal injury or death. The weight may be attained with a front end loader, front wheel weights, ballast in tires or front tractor weights. When attaining a minimum 20% of tractor and equipment weight on the front wheels, you must not exceed the ROPS weight certification. Weigh the tractor and equipment. Do not guess or estimate!
22. Inspect the entire machine periodically². Look for loose fasteners, worn or broken parts, and leaky or loose fittings.
23. Use only the driveline supplied with the rotary cutter. Do not use it if it is missing any shield or safety protection.
24. Pass diagonally through sharp dips and avoid sharp drops to prevent "hanging up" tractor and implement.
25. Avoid sudden starts and stops while traveling up or downhill.
26. Always cut down slopes; never across the face. Avoid operation on steep slopes. Slow down on sharp turns and slopes to prevent tipping and/or loss of control.

3.02 - Setup

Notice to dealer: Pre-delivery setup and service including lubrication is the responsibility of the authorized dealer. It is up to him to assure that the machine is in perfect condition and ready to be used. It is his responsibility to ensure that the customer is aware of all safety aspects and operational procedures for the rotary cutter. He must also fill out the Pre-Delivery Checklist³ prior to delivering the rotary cutter.

3.03 - Assembly Instructions



WARNING: Secure rotary cutter with a hoist before removing the crate from the unit, carefully lower it to the ground after hardware and crating material has been removed. The implement is very heavy and a sudden fall could cause serious injury or death.

For transportation purposes the front chain guard is assembled backwards and the three point hitch of the rotary cutter is shipped unassembled. To assemble proceed as follows:

1. Unbolt the front chain guard and bolt it so the chains are to the outside.

² See Chapter 4 - Maintenance.

³ See Chapter 7 - Pre-Delivery Checklist.

2. Top hitch supports come installed, but are lowered on the frame. Loosen bolts to raise them and ensure they are installed to the **inside** of the front support plates welded on the front of the cutter frame.
3. Install the top hitch arms to the **inside** of the rear cutter frame using the M14x35 bolts and the M14 nuts provided. Bolt loosely at first.
4. Disassemble top hitch plate in order to position top hitch arms. Reassemble as follows: M16x150 bolt, top hitch support, top hitch arm, top hitch plate, spacer, top hitch plate, top hitch arm, top hitch support, nut M16. **Be sure the top hitch plate swings freely.**
5. Install driveline and ensure it has at least 2" from bottoming out in its shortest working position and has the minimum 6" overlap in its longest working position. Refer to **Section 4.05⁴** of this manual, if it is determined that the driveline is too long and needs to be shortened. Contact your local dealer if it is determined that the driveline is too short for your tractor.
6. Bolt up the tail wheel (in larger models it may be unassembled) and insert the rear bolt in the desired cutting height position.
7. Grease the wheel yoke, the wheel hub, the PTO shaft and check the gearbox for oil. It should be approximately half full.
8. Ensure all hardware is properly tightened.



CAUTION: Stand clear of bands when cutting as they could be under sufficient tension to cause them to fly loose. Take care in removing bands and wire. They often have extremely sharp edges and cut very easily.

3.04 - Cutting Height Adjustment



WARNING: Keep hands and feet away from moving blades.

Be sure tractor engine is off, parking brake is locked, and key is removed before making any adjustments.

Never rely on the tractor lift system. Install blocks or stands under the rotary cutter deck to prevent it from falling.

The cutting height is the distance from the blades to the ground which is determined by the position of the tail wheel.

The cutting height is adjustable from 1" to 9¼".

To adjust the cutting height, do the following (**see fig. 3**):

1. Remove the bolt holding the wheel arm.

⁴ See Section 4.05 - Driveline, for instructions on how to determine correct driveline length and procedures for shortening the driveline.

2. Position the wheel to the desired height and replace the bolt in the appropriate hole. The wheel arm holder has four hole positions. Of the four holes, the upper hole is for the lowest cutting height, and the lower hole, the one closest to the ground, is for the highest.
3. Properly tighten the bolt.

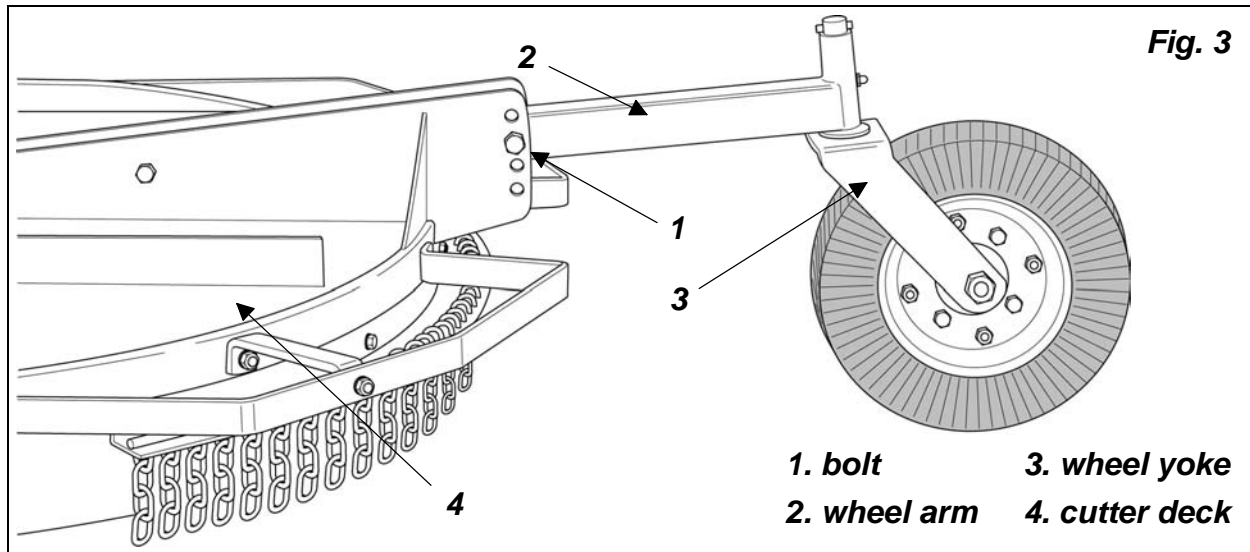

IMPORTANT: Very low cutting heights should be avoided. Damaging shock loads occur when the blades strike the ground repeatedly. This can cause damage to the cutter.

3.05 - Pre-Operational Check

IMPORTANT: Check each of the following, carefully, prior to engaging the equipment:

1. The oil level in gearbox. Using a flashlight, check inside the gearbox to verify that it's approximately half full.
2. The wheel arm and wheel bearing have been greased.
3. The driveline cross and bearings and the inner and outer locking rings have been greased.
4. No wrappings or foreign objects are around the blades, rotor or driveline.
5. The blades are properly installed and the blade bolts properly torqued⁵.
6. All hardware is tight⁶.
7. The tractor, to ensure correct direction of PTO and rpm speed.
8. All safety shields and guards are in place and tightly attached.
9. No people or animals are in the work area.

⁵ See Removing or Installing Blades in section 4.03 - Blade Maintenance, for details.

⁶ See Table 1 - Torque Specifications, page 28.



DANGER: Stay clear of rotating driveline. Entanglement in rotating driveline can cause serious injury. Disengage PTO, engage parking brake or place transmission in “Park”, shut off the tractor and remove the key before working around hitch, attaching or detaching driveline, making adjustments, servicing or cleaning the machine.

3.06 - Attaching to the Tractor

Unit may be used on tractors ranging from 35 to 80 HP equipped with a standard rear PTO and category 1 three point hitch⁷. **Never use this rotary cutter with tractors over 80 HP.**



CAUTION: Check the tractor PTO rpm and its direction of rotation to ensure that they correspond to what is indicated on the machine.



WARNING: Disengage PTO, wait for all movement from the implement and tractor to stop, engage parking brake or place transmission in “Park”, shut off the tractor and remove the key before attaching the implement to the tractor.



DANGER: Tractor-implement combinations can create unstable unions with a chance of rollover. If necessary, front weights need to be added to the tractor in order to maintain balance. Always ensure that the tractor tire pressure is correct according to the tractor operator's manual.

To attach the rotary cutter to the tractor do the following:

1. Back the tractor up to the rotary cutter in order to slip the tractor hitch arms over the hitch pins bolted to the rotary cutter hitch arms. **Turn off the tractor engine.** Secure them in place with the lynch pins. **Failure to ensure a secure coupling of the implement to the tractor can cause injury and damage to the implement or tractor.**
2. Adjust the tractor sway blocks or chains to remove all side movement.
3. Attach the top link. Adjust tractor top link to allow the rotary cutter to follow the ground contour. In this position the top hitch plate is able to float.
4. Install the shielded driveline to the tractor by first lining up the splines and depressing the snap pin. Push the yoke onto the PTO shaft as far as it will go. Release the pin and pull back slowly until the pin clicks in place. Repeat this operation on the implement end.

⁷ See Table 2 - Technical Features, page 28.

5. Attach the driveline chains to the tractor and to the rotary cutter to keep the driveline protection from turning. The chains should not be too tight.

3.07 - Start Up



DANGER: The rotary cutter must always be lowered to the ground before starting tractor engine or engaging PTO lever. Lower the implement with the tractor rockshaft control lever until the deck is horizontal to the ground or slightly tilted so that the front of the deck is lower than the rear. In normal working conditions it is generally recommended to tilt the deck forward by 1" to 2" so that the blades cut material only at the front of the deck. This cutting position will prolong the life of the blades and to use less horsepower throughout the operation.

If, instead, a better shredding of the material is desired, level the deck horizontal or slightly raise the front of the deck so that the front is higher than the rear.

If the cutting height is not correct, change the setting using the tail wheel⁸.

With the engine idling, slowly engage the PTO drive. Move the throttle lever until the PTO speed indicated on the cutter is obtained. The machine is normally set for a PTO speed of 540 rpm.

Shift the transmission to a slow speed gear and start forward, increase the ground speed by shifting upward until the desired speed is obtained.

Do not mow in reverse unless absolutely necessary and only after careful observation of the area behind the rotary cutter.



CAUTION: Do not operate this rotary cutter at a PTO speed or direction of rotation other than that shown on the rotary cutter. Serious damage can occur to the machine and/or the operator.

Before starting to mow, never forget that the **operator is responsible** for the following:

1. Safe and correct driving of the tractor and rotary cutter.
2. To learn precise safe operating procedures for both the tractor and the rotary cutter.
3. To ensure all maintenance and lubrication has been performed on the rotary cutter.
4. To have read and understood all safety aspects for the rotary cutter in the operator's manual.
5. To have read and understood all safety decals on the rotary cutter.
6. Checking the condition of the blades. Worn or damaged blades should be changed before starting⁹.
7. Checking to ensure that the cutting edge is the leading edge of the blade.

⁸ See Section 3.04 - Cutting Height Adjustment.

⁹ See Section 4.03 - Blade Maintenance.

8. Checking that there is no wire, weed, grass or other material wrapped around blades.
9. Checking to see if front weights need to be added to the tractor in order to maintain balance.
10. Checking the tractor tires for the proper pressure in accordance with the tractor operator's manual.
- 11. Checking that the driveline guard, the front and rear shields and all other shielding are on the machine and securely in place.**
12. Making sure the proper attire is worn. Avoiding loose fitting clothing which can become entangled. Wearing sturdy, tough-soled work shoes and protective equipment for eyes, hands, ears and head. Never operate tractor or implement barefoot, or wearing sandals or sneakers.
13. Checking area for stones, branches and other debris that might be thrown.
14. Ensuring proper lighting is available, sunlight or good artificial lighting.

3.08 - Working Speed

The mowing speed depends on ground conditions, tractor HP, mowing height and grass thickness. Only a test run will enable you to gauge the optimal working speed for your conditions. Under most conditions a 2 to 6 mph ground speed is best. In order to obtain the best cut possible, always keep the tractor rpm up to the speed indicated on the rotary cutter. When increasing or decreasing mowing ground speed, always use gear selection, not engine speed. This will maintain the constant maximum blade speed necessary for a clean cut.



WARNING: Never operate without all shields on the machine and securely in place. The cutter blades can throw objects hundreds of feet which could result in personal or property damage. Pick up all rocks and other debris before mowing. Enter new areas carefully. Cut grass higher at first, allowing the machine to clear hidden objects.



CAUTION: For emergency reasons learn how to stop the tractor and cutter quickly. On the rotary cutter always disengage the PTO, lock parking brake, stop engine and allow the blades to come to a complete stop before dismounting the tractor.

3.09 - Uneven Terrain



DANGER: Be careful of rollover when operating tractor and rotary cutter over uneven ground.

The following precautions should always be observed when working on uneven terrain:

1. In extremely uneven terrain rear wheel weights, front tractor weights, and/or tire ballast should be used to improve stability.
2. Observe the type of terrain and develop a safe working pattern.
3. Whenever traction or stability is doubtful, first test drive over the terrain with the PTO disengaged.
4. Operate the implement up and down steep slopes, not across slopes, to prevent the tractor from tipping. Avoid sudden stops and starts, and slow down before changing directions on a slope.
5. Pass diagonally through sharp dips and avoid sharp drops to prevent hanging up the tractor and implement.
6. Slow down on sharp turns and slopes to prevent tipping or loss of control.
7. Avoid tipping the mower while cutting.
8. Watch for holes, roots or other hidden objects. Do not use near the edge of a gully, ditch or stream bank.

3.10 - Removing Rotary Cutter from the Tractor



CAUTION: Disengage tractor PTO. Set parking brake. Stop engine and remove key from ignition. Disconnect rotary cutter driveline from tractor PTO shaft. Collapse driveline and store in appropriate place. Disconnect three point linkage and carefully drive tractor away from rotary cutter.

3.11 - Transport

Before raising the rotary cutter for transport, the tractor top link must be adjusted so when lifted, the rear of the machine is higher than the front. To do this, shorten the tractor top link until the top hitch plate is locked forward and no longer able to pivot. This will keep the rotary cutter locked in position and minimize the shaking and bouncing during transport which can damage the hitch or frame.



CAUTION: Make sure PTO is disengaged and blades have stopped turning before raising rotary cutter to full transport position. Do not tow tractor and rotary cutter

behind other vehicles. Use a properly equipped trailer with heavy tie-downs for towing operations.

Before transporting:

1. Always select a safe ground speed that is appropriate for the terrain.
2. Beware of traffic on public roads. Install a SMV (Slow Moving Vehicle) sign when traveling on roads or streets. Comply with all federal, state and local laws.
3. Reduce ground speed when turning and take care that the implement does not strike obstacles such as trees, fences or buildings.
4. Always disengage PTO before raising the implement to transport position.
5. When raising the mower be sure the PTO driveline does not hit either the mower or the tractor.
6. During transport the mower should not be lifted over 14"-16" from the ground.

4 - MAINTENANCE



DANGER: Stop engine, lock parking brake and remove key before performing any service or maintenance.

Never rely on the tractor lift system. Install blocks or stands under the rotary cutter deck to prevent it from falling.

Always use personal protection devices, such as glasses or gloves when performing maintenance. Keep fingers out of slots to prevent injury.

4.01 - Maintenance Safety



1. Good maintenance is your responsibility.
2. Keep service area clean and dry. Be sure electrical outlets and tools are properly grounded. Use adequate light for the job at hand.
3. Make sure there is plenty of ventilation. Never operate the engine of the towing vehicle in a closed building. The exhaust fumes may cause asphyxiation.
4. Make no repair or adjustments with the tractor engine running. Before working on the machine, disengage the PTO, shut off the engine, set the brakes, and remove the ignition key.
5. Be certain all moving parts on attachment have come to a complete stop before attempting to perform maintenance.
6. Never work under equipment unless it is blocked securely.
7. Always use personal protection devices such as eye, hand and hearing protectors, when performing any service or maintenance.
8. Frequently check rotary cutter blades. They should be sharp, free of nicks and cracks and securely fastened.
9. Periodically tighten all bolts, nuts and screws and check that all cotter pins are properly installed to ensure unit is in a safe condition.
10. When completing a maintenance or service function, make sure all safety shields and devices are installed before placing unit in service.
11. After servicing, be sure all tools, parts and service equipment are removed.
12. Never replace hex bolts with less than grade five bolts unless otherwise specified, i.e. shear bolts¹⁰.
13. Where replacement parts are necessary for periodic maintenance and servicing, genuine replacement parts must be used to restore your equipment to original specifications. The company will not claim responsibility for use of unapproved parts and/or accessories and other damages as a result of their use.

¹⁰ Refer to Table 1 - Torque Specifications, page 28.

14. Unauthorized modifications to the machine may impair the function and/or safety of the machine and reduce its life. If equipment has been altered in any way from original design, the manufacturer does not accept any liability for injury or warranty.

4.02 - Service

The accompanying illustrations show lubrication points. The chart gives the frequency of lubrication in hours, based on normal operating conditions. Severe or unusual conditions may require more frequent lubrication.

Use a good quality SAE multipurpose type grease for all locations shown. Be sure to clean fittings thoroughly before using grease gun.

Use 90 wt gear oil in gearbox.

Hourly:

1. Check the condition of cutter blades for nicks or dull edges.
2. Sharpen if necessary. Replace bent or damaged blades¹¹.
3. Also check blades for damage after hitting an obstruction.
4. Clean foreign material from the deck.

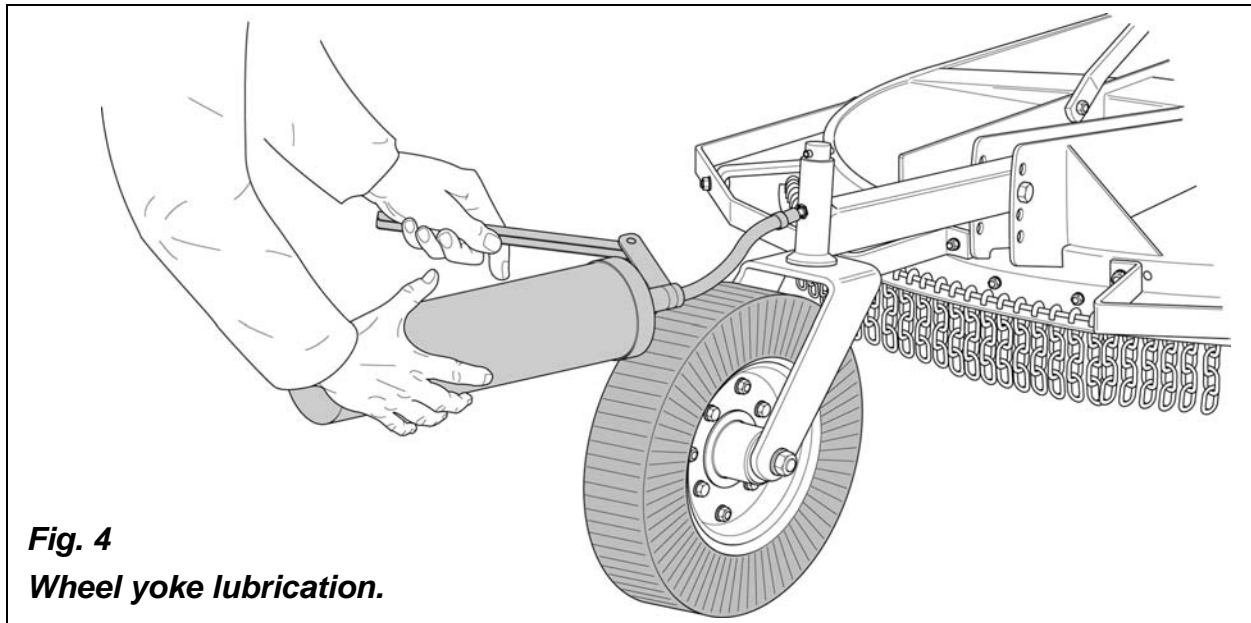

Fig. 4
Wheel yoke lubrication.

Every 8 hours:

1. **Lubricate driveline, lubricate caster wheel and tail wheel yoke (see fig. 4, 5 & 6):** Apply two or three shots of grease to the driveline cross and bearings and to the inner and outer locking rings (see fig. 6); apply the same amount to the wheel yoke (see fig. 4) grease fittings and the wheel grease fittings (see fig. 5). (See the driveline manufacturer operator's manual for further information on the driveline.)
2. **Gearbox oil level:** Check gearbox oil level by removing the breather plug. Using a flashlight, check inside the gearbox to verify that it is approximately half full. When

¹¹ See Removing Blades in section 4.03 - Blade Maintenance, for details.

filled correctly the oil level should be approximately halfway on the input shaft. When fully drained gearbox requires approximately 44 fl. oz. (1.4 qt.) of oil. If needed add SAE 90W gear oil.

Note: Never overfill gearbox. Oil will expand when hot. Overfilling will likely cause excess oil to blow out of breather cap.

Fig. 5
Tail wheel lubrication.

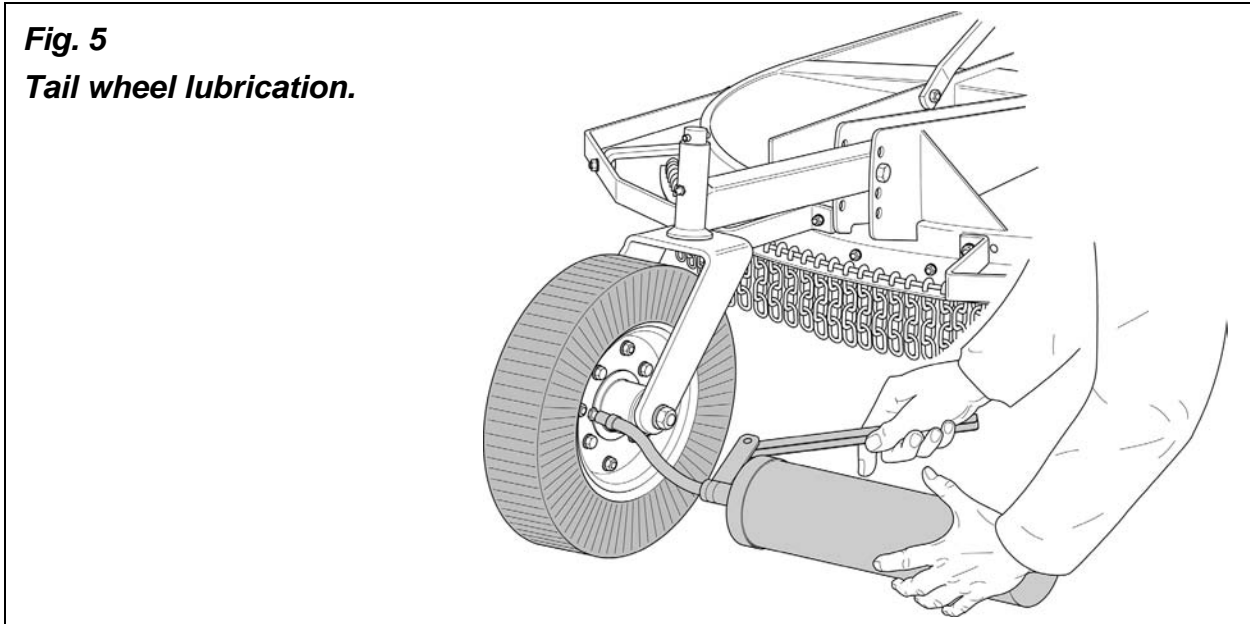

Every 20 hours: Lubricate the driveline telescoping shafts: Apply a thin film of grease on the inner tube of the driveline (see fig. 6).

Fig. 6 - Driveline lubrication points.

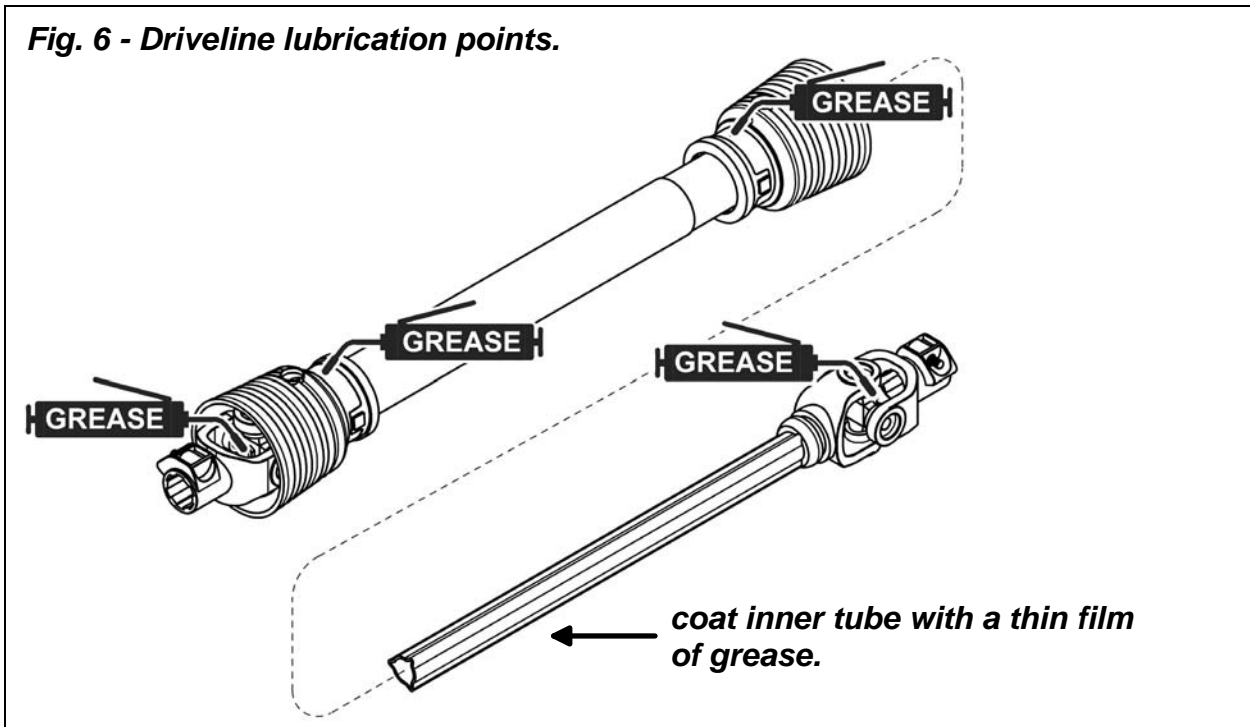

Every 25 hours: Check hardware tightness; rotary cutter vibrations can loosen bolts. Check tightness of the hardware periodically, using **Table 1** as a guide¹².

4.03 - Blade Maintenance



WARNING: To avoid possible injury, wear proper eye and hand protection when servicing cutter blades.

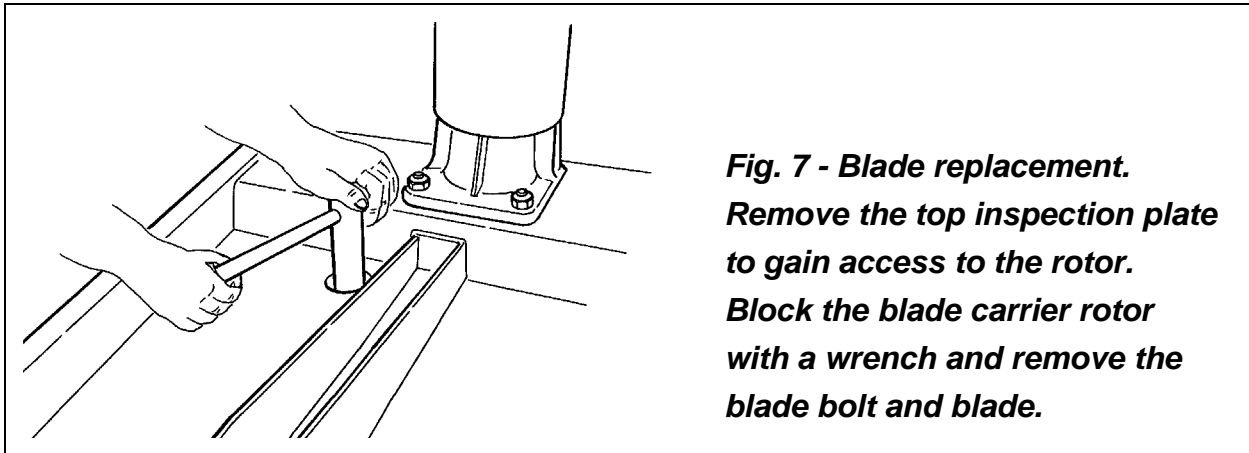

Fig. 7 - Blade replacement.
Remove the top inspection plate to gain access to the rotor.
Block the blade carrier rotor with a wrench and remove the blade bolt and blade.

Proper blade maintenance is important in order for the cutter to work properly, to always obtain a precision cut and to lower HP requirements thus keeping costs down. Blades must be kept sharp, at their original length and with corners intact. A blade must be replaced if, due to wear or damage, its original shape has been distorted. Blade sharpening is extremely important in order to get the best cutting results.

Removing or installing blades

Never rely on the tractor lift system to support the machine while working underneath. Install blocks or stands under the cutter deck to prevent it from falling.

To replace the blades, proceed as follows:

1. Remove the top inspection plate to gain access to the rotor (**see fig. 7**).
2. Block the blade carrier rotor with a wrench and remove the blade bolt nut.
3. Remove the blade bolt and blade (**see fig. 9**).
4. Check the bolt for wear. Replace if necessary.
5. Place the new blade making sure that the cutting edge is towards the direction of rotation. The blade turns in a clockwise direction when viewed from the bottom of the deck (**see fig. 8**).
6. Insert the blade bolt into the new blade and install into blade carrier rotor.
7. Properly torque the nut M27-2.00 class 6.8 to **265 lb.ft.**

¹² See Table 1, Torque Specifications, page 28.

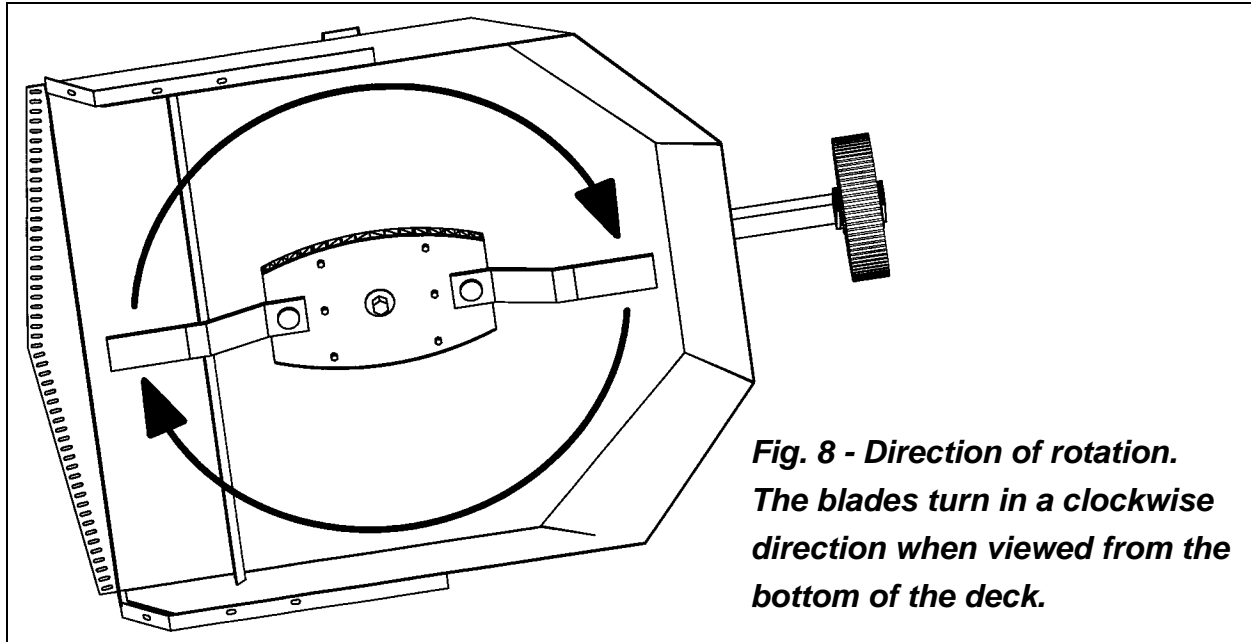

Fig. 8 - Direction of rotation.
The blades turn in a clockwise direction when viewed from the bottom of the deck.

IMPORTANT: Check blade bolt torque every 8 hours. Ensure the blades are able to free-swing. This is extremely important to prevent damage to the cutter.

IMPORTANT: When installing new blades, it is important that they be the same type and the same weight to ensure balance. An unbalanced rotor blade carrier can damage the cutter.



WARNING: Do not substitute blades or the blade retaining bolt with non original parts. Company blades and blade retaining bolts are specially made for this application. Using non original parts can affect the quality of cut and may also cause damage to the rotary cutter.



DANGER: Proper torque must be used when tightening the blade retaining bolt. If these safety precautions are not followed, the blade could come off during operation and be thrown hundreds of feet from the rotary cutter.

4.04 - Rotor & Stump Jumper Assembly

To assemble the stump jumper to the rotor on the **60" model** do the following:

1. Position the rotor bar on the stump jumper so the holes line up.
2. Attach the rotor to the stump jumper with the bolts provided (2 bolts M16-2.00x50) and nuts (**see fig. 9**). Torque to proper setting.

To assemble the stump jumper to the rotor on the **72" model** do the following:

1. Position the rotor bar on the stump jumper so the holes line up.
2. Attach the two support plates to the rotor with the bolts provided (2 bolts M16-2.00x55 & 4 bolts M16-2.00x30) and nuts (**see fig. 9**). Torque to proper setting.

To assemble the rotor/stump jumper assembly on the rotary cutter do the following:

1. Insert the rotor/stump jumper assembly on the pinion shaft.
2. Bolt on the castle nut M30-2.00 class 5.8 (**see #7, fig. 9**) and torque to **738 lb.ft.**
3. Insert the castle nut cotter pin (**see #8, fig. 9**) and ensure it is seated into the rotor properly.

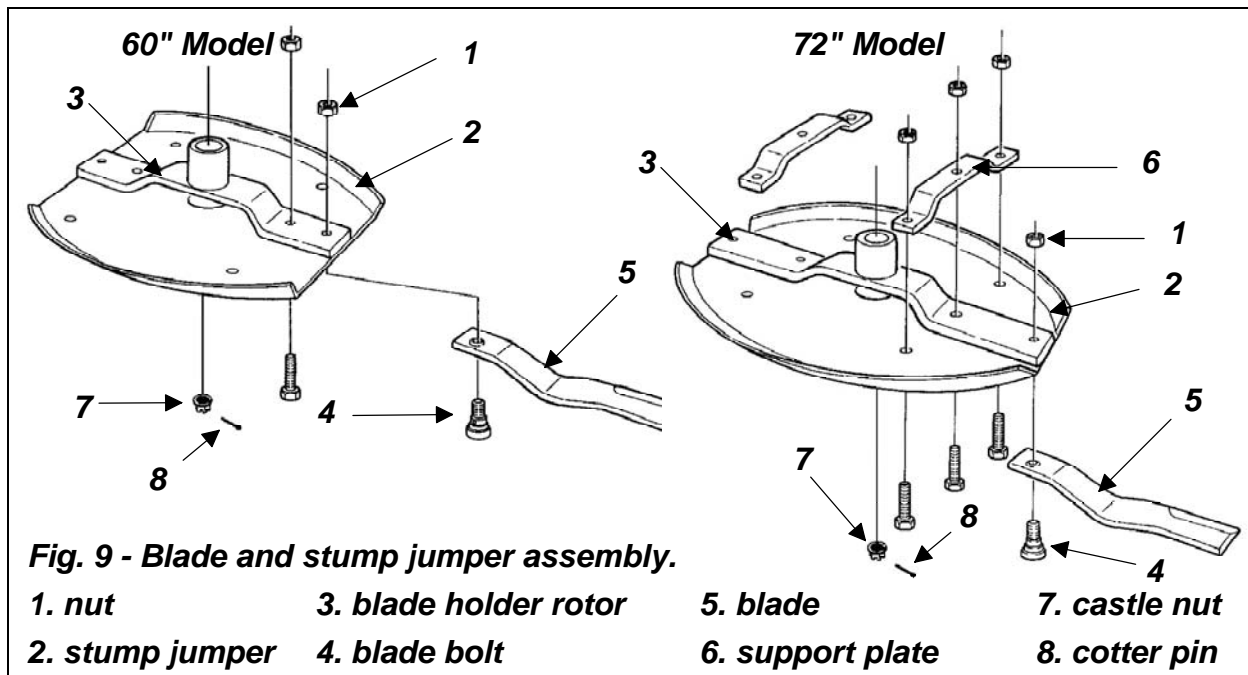

4.05 - Driveline



DANGER: Only use the original driveline supplied with this machine and always with the safety shielding. Carefully read and file away the driveline operator's manual supplied by the manufacturer. The following does not substitute the information found in the driveline manual.

IMPORTANT: Always check driveline length during initial setup and when connecting to a different tractor.

In the collapsed position the driveline should be approximately 2" from bottoming out to prevent possible damage to the tractor or implement. When the driveline is in the

maximum extended position, the ideal minimum overlap of the two halves should be approximately 6" (see fig. 10).

Fig. 10

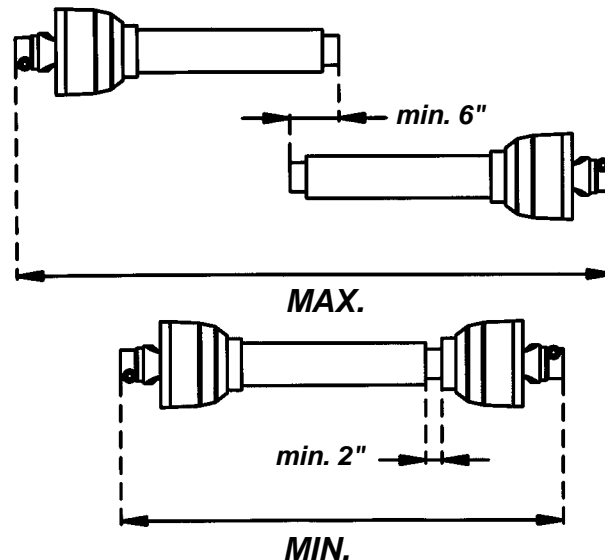

If determined that the driveline is too long, follow these procedures to adjust the length:

1. Separate the two driveline halves. Connect one half to the tractor PTO and the other half to the rotary cutter.
2. Raise and lower the rotary cutter with the 3 point hitch to find the position where the driveline is shortest. Hold the half shafts side by side and mark the desired length on the outer female tube guard leaving a 2" gap between the end of the guard tube and bell guard.
3. Cut off both guard tubes the same amount as marked in step 2.
4. Shorten both drive tubes the same amount as guard tubes.
5. De-burr and clean filings from drive tubes and apply grease to outside of inner telescoping tube.
6. Reassemble the driveline halves and connect to tractor and rotary cutter. Raise and lower rotary cutter again to be sure driveline does not bottom out in its shortest position and has a minimum overlap of 6" in the longest position.
7. Install both driveline safety chains. One should be hooked in a hole on the outer driveline yoke shield and to the tractor to restrict outer shield rotation. The second one should be hooked in a hole on the inner driveline yoke shield and to the rotary cutter to restrict inner shield rotation.

If determined that the driveline is too short for your tractor, contact your local dealer.



CAUTION: Always work with the driveline as straight as possible. This will prolong its life and that of its components. It is advised not to work at an angle greater than 15 degrees.

4.06 - Safety Slip Clutch

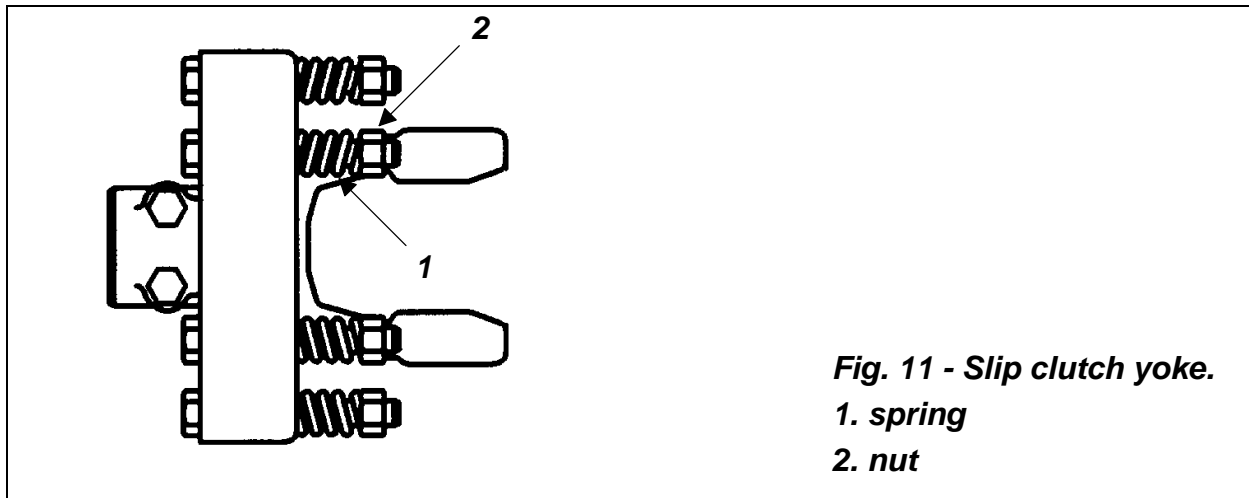







The driveline is supplied with a safety slip clutch, it is important to ensure it is working properly. The slip clutch delivered with your machine is set at a specific torque for normal working conditions.

While working, if the clutch slips frequently for no apparent reason, the spring nuts need to be tightened by $\frac{1}{2}$ turn. Check the clutch after 600-800 ft., if necessary repeat the operation. If, after tightening the nuts down, the clutch continues to slip, the discs will have to be replaced (**see fig. 11**). Follow the instructions in reverse, if while working under normal conditions the clutch does not slip at all.



CAUTION: Check the tractor master shield over the PTO stub shaft. Make sure it is in good condition and fastened securely to the tractor. Purchase a new shield if old shield is damaged or missing. When you are using a driveline equipped with a slip clutch, ensure that the slip clutch shield is properly mounted to the gearbox and in good condition.

TABLE 1 - TORQUE SPECIFICATIONS

Metric (ISO) treaded bolts head marking							Inch (SAE) treaded bolts head marking								
	Class 5.8		Class 8.8		Class 10.9			Grade 2		Grade 5		Grade 8			
Bolt size mm	Thread mm	N.m	ft-lb	N.m	ft-lb	N.m	ft-lb	Bolt size inch	Thread inch tpi	N.m	ft-lb	N.m	ft-lb	N.m	ft-lb
M5	0.8	4	3	6	4	9	7	1/4"	20	7	5	11	8	16	12
M6	1	6	4	10	7	15	11	1/4"	28	8	6	13	10	19	14
M8	1.25	16	12	25	18	36	27	5/16"	18	15	11	24	17	33	25
M8	1	17	13	26	19	38	28	5/16"	24	17	13	26	19	37	27
M10	1.5	31	23	48	35	71	52	3/8"	16	27	20	42	31	59	44
M10	1.25	33	24	51	38	75	55	3/8"	24	31	23	47	35	67	49
M10	1	35	26	53	39	78	58	7/16"	14	43	32	67	49	95	70
M12	1.75	54	40	84	62	123	91	7/16"	20	48	36	75	55	106	78
M12	1.5	56	41	87	64	128	94	1/2"	13	66	48	102	75	144	106
M12	1.25	59	44	90	66	133	98	1/2"	20	75	55	115	85	163	120
M14	2	84	62	133	98	195	144	9/16"	12	95	70	147	109	208	154
M14	1.5	94	69	142	105	209	154	9/16"	18	106	79	164	121	232	171
M16	2	131	97	206	152	302	223	5/8"	11	132	97	203	150	287	212
M16	1.5	141	104	218	161	320	236	5/8"	18	149	110	230	170	325	240
M18	2.5	181	133	295	218	421	310	3/4"	10	233	172	361	266	509	376
M18	2	196	145	311	229	443	327	3/4"	16	261	192	403	297	569	420
M18	1.5	203	150	327	241	465	343	7/8"	9	226	167	582	430	822	606
M20	2.5	256	189	415	306	592	437	7/8"	14	249	184	642	473	906	668
M20	1.5	288	212	454	335	646	476	1"	8	339	250	873	644	1232	909
M22	2.5	344	254	567	418	807	595	1"	12	371	273	955	704	1348	995
M22	1.5	381	281	613	452	873	644	1-1/8"	7	480	354	1077	794	1746	1288
M24	3	444	327	714	526	1017	750	1-1/8"	12	539	397	1208	891	1958	1445
M24	2	488	360	769	567	1095	808	1-1/4"	7	677	500	1519	1120	2463	1817
M27	3	656	484	1050	774	1496	1103	1-1/4"	12	750	553	1682	1241	2728	2012
M27	2	719	530	1119	825	1594	1176	1-3/8"	6	888	655	1992	1469	3230	2382
M30	3.5	906	668	1420	1047	2033	1499	1-3/8"	12	1011	746	2268	1673	3677	2712
M30	2	1000	738	1600	1180	2250	1659	1-1/2"	6	1179	869	2643	1949	4286	3161
M36	4	1534	1131	2482	1830	3535	2607	1-1/2"	12	1326	978	2974	2194	4823	3557

When using lock washers with nuts, increase torque values by 5%.

TABLE 2 - RMD ROTARY CUTTERS - TECHNICAL FEATURES

Series RMD, for tractors up to 80 HP, PTO 540 rpm, 3 point hitch cat. 1*											
Model	HP	Working width	Overall width	Weight lb.	Deck	Rotor rpm/min	Blades tip speed ft/min	# of blades & size	Cutting height	Laminated wheel size	Driveline 1 3/8" ASAE Cat. 4
RMD-360	35-80	60"	68"	695	round	855	13189	2 - 1/2"x4"	1"-9 1/4"	4"x8"x15"	w/slip clutch
RMD-372	40-80	72"	80"	785	round	855	15748	2 - 1/2"x4"	1"-9 1/4"	4"x8"x15"	w/slip clutch

*Because of possible injury from thrown objects, all rotary cutters are potentially dangerous. Any rotary cutter intended for use along roadways or other locations where people may be present must be used with safety shielding in place.

5 - REPAIR PROCEDURES



CAUTION: All repair procedures must be done by authorized dealerships. It is not recommended that untrained individuals perform any repair work. The following operations are detailed for qualified personnel only.

5.01 - Gearbox

To remove the gearbox from the frame do the following:

1. Never rely on the tractor lift system. Install blocks or stands under the cutter deck to prevent it from falling.
2. Remove the castle nut cotter pin (**see #8, fig. 9**).
3. Remove the castle nut (**see #7, fig. 9**) securing the blade carrier rotor to the pinion shaft. Remove the rotor. Be sure to leave the washer on the pinion shaft.
4. Remove the bolts holding the gearbox to the frame and remove the gearbox.

If it is necessary to open the gearbox and replace internal parts, be sure to replace any oil seals or gaskets to ensure a tight fit when reassembling.

To replace the gearbox, reverse the above operations, making sure the castle nut (**see #7, fig. 9**) securing the blade carrier rotor is torqued to **738 lb.ft.** and that the cotter pin (**see #8, fig. 9**) is installed properly.

5.02 - Suggested Spare Parts

It is suggested that the following spare parts be kept on hand for the rotary cutter at all times to prevent a minor problem from delaying work.

Description	Quantity
Blades	2
Blade bolts	2

5.03 - Storage

After seasonal use it is important to perform the following for prolonged storage:

1. Wash the rotary cutter carefully.
2. Inspect the rotary cutter and replace worn or damaged parts.
3. Tighten all hardware.
4. Grease all areas indicated under Maintenance¹³.

¹³ See Chapter 4 - Maintenance.

5. Touch up scratches by sanding the area and applying a light coat of primer and paint to prevent rust from forming.
6. Cover the rotary cutter from the elements in order to have it in perfect condition for the start of the next season.
7. Store driveline in dry area. A slip clutch can become inoperative if the discs stick together. Be sure to check the clutch before using the rotary cutter after prolonged storage.
8. Make sure all parked machines are on a hard, level surface, and engage all safety devices.
9. Do not permit children to play on or around the stored unit.

Touch up paint available:	
Part #	Description
7300007	Primer, gray - aerosol spray can
7300008	Paint, Befco orange - aerosol spray can
7300010	Paint, Befco black - aerosol spray can



WARNING: Be sure to store the implement on a hard level surface and away from people especially children.

Note: The machine demolition operations should be carried out in compliance with all federal, state and local environment protection laws.

6 - TROUBLESHOOTING



WARNING: Be sure tractor engine is off, parking brake is locked, and key is removed before making any adjustments.

PROBLEM	POSSIBLE CAUSE	SOLUTION
Irregular cut.	Cutter is not hooked up level. Blades are worn or bent.	Adjust three point hitch to level out the cutter. Replace blades.
Material not cut or laid over.	Wrappings around rotor. Cutter is not hooked up level. Tractor PTO speed too slow. Slip clutch slipping.	Remove wrappings. Adjust three point hitch to level out the cutter. Check tractor PTO speed. Check slip clutch.
Cutter is noisy.	Loose hardware. Gearbox oil level is low.	Tighten hardware. Add oil to gearbox.
High wear on blades.	Blades hitting ground.	Raise cutting height.
High wear on blade mounting holes (blade bolts).	Cutter is not working at the proper PTO rpm speed.	Check tractor PTO speed.
Vibrations.	Wrappings around blades. Improper tractor PTO speed. Unbalanced blades.	Remove wrappings. Check tractor PTO speed. Replace blades with identical pairs (the same weight).
Material bunching.	Material is too wet. Material is too high.	Allow material to dry. Raise cutting height. Reduce ground speed. Make two passes to cut.
Machine smells hot or begins to smoke.	Slip clutch slipping. Gearbox oil low.	Check slip clutch. Check oil level in gearbox.
Oil blowing out of gearbox breather cap.	Gearbox overfilled.	Use a siphon pump to drain excess oil out of gearbox.

7 - PRE-DELIVERY CHECKLIST

To the dealer: Inspect the machine thoroughly after assembly to assure it is functioning properly before delivering it to the customer. The following checklist is a reminder of points to cover. Check off each item as it is found satisfactory or after proper adjustment is made.

- Gearbox oil level.
- Guards and shield properly fastened.
- Lubrication of grease fittings.
- All hardware properly tightened.
- All decals properly located and readable (**see fig. 2**).
- Blades properly installed, blade bolts and nuts tightened.
- Overall condition (touch up scratches, clean and polish).
- Test run, check for excessive vibration or overheating of bearings.
- Operator's Manual.

Review the Operator's Manual with the customer. Explain the following:

- Warranty.
- Safe operation and service.
- Correct machine installation and operation.
- Daily and periodic lubrication, maintenance and inspections.
- Troubleshooting.
- Operational procedures and storage.
- Parts and service.
- Fill out the Pre-Delivery Checklist and Warranty Registration form.
- Give customer the Operator's Manual and encourage the customer to read the manual carefully.

IMPORTANT: Warranty is not valid unless Pre-Delivery Checklist and Warranty Registration form in Operator's Manual is completed in detail and mailed to the Company.

Model Number: _____

Serial Number: _____

Delivery Date: _____

Dealer's Signature: _____

8 - WARRANTY

BEFCO's responsibility will be limited to substitution of the acknowledged defective merchandise to the same place of delivery as the previous one was supplied.

1. LIMITED WARRANTY

BEFCO, Inc. herein referred to as the Company, warrants its machines and related accessories, hereafter referred to as the Machine, to be free from defects in material and workmanship, for a period of twelve (12) months from the date of invoice to the first registered owner; this limited warranty does not apply to common wear items and excludes belts, shear pins, oil, grease, tires, tubes, hydraulic hoses, knives and PTO shafts.

Labor will be reimbursed at \$40.00 per hour based on BEFCO's time schedule.

Cost of transport to the servicing dealer is the responsibility of the customer.

Warranty coverage shall not be transferable from the first owner to any subsequent owner.

2. DISCLAIMER OF ALL OTHER WARRANTIES AND REMEDIES

Neither the Company nor any company affiliated with the Company makes any warranties, representations or promises, expressed or implied, as to the quality, performance or application of its products other than those set forth herein and does not make any implied warranty of merchantability or fitness.

The only remedies the purchaser has in connection with the breach, or performance of any warranty on the Company's Machine are those set forth herein. In no event will the dealer, the Company, or any company affiliated with the Company, be liable for:

- a. Injuries or damages of any kind or nature, direct, consequential or contingent to person or property.
- b. Any expenses incurred by the owner to repair, replace or rework any allegedly defective item.
- c. Any loss, cost, forfeiture or damages (including loss of profits; loss of crops; loss because of delay in field operations; any expenses or loss incurred for labor, supplies, substitute machine rental; liabilities of the owner to its customers or third persons; and all other consequential damages, losses, liabilities or damages for any other reasons) whether direct or indirect, and whether or not resulting from or contributed to by the default or negligence of the Company, its agents, employees and subcontractors which might be claimed as a result of the use or failure of the equipment delivered.

The Company's liability based on this limited warranty or any other applicable laws shall be limited to replacement or refund of the purchase price of the product.

The limited warranty extended herein gives you specific rights and you may also have other rights which vary from state to state. Neither the dealer nor the Company personnel has the authority to make any representation or to modify the terms and limitations of this warranty in any way.

Other than the limited warranty extended hereby there is no other expressed warranty in connection with the design, safety or use of any of the Company's products except as to title. All implied warranties are expressly disclaimed pursuant to the terms of this warranty.

3. CUSTOM WORK

If the Machine is used for commercial purposes such as custom work, the period warranted for the Machine is limited to six (6) months from the date of delivery to the first registered owner and does not cover any labor charges incurred.

4. RENTAL

If the Machine is used for rental purposes the period warranted for the Machine is limited to thirty (30) days from the date of delivery to the first registered owner and does not cover any labor charges incurred.

5. REGISTRATION

In order to qualify for coverage on this limited warranty, the product and name of the original purchaser must be registered with the Company by a completed Machine Pre-Delivery Checklist and Warranty Registration along with a copy of the dealer's invoice to the first registered owner to the Company within fourteen (14) days after the date of delivery to the original purchaser.

6. WARRANTY SERVICE

Warranty Service must be performed by a dealer authorized by BEFCO. If the warranty service requested is approved, the owner shall pay only for labor beyond the rate allowed, for overtime labor, and for any mileage charge for transporting the equipment to and from the dealer's shop. It is assumed that the dealer has the appropriate general and special tools to service the Machine. Time required for replacement of knives, oil, grease and to remove excessive dirt from the Machine is not subject to reimbursement by the Company. The owner is required to clean the Machine before presenting it to the dealer for service work. The Machine must be delivered within thirty (30) days after failure date by the owner to the dealer to be eligible for warranty consideration.

7. UNAPPROVED SERVICE OR MODIFICATION

All obligations of the Company under this limited warranty shall be terminated if:

- a. Proper service and operation instructions as outlined in the Operator's Manual and on the instruction sticker on the Machine, are not followed.
- b. The Machine is modified or altered in any way not approved by the Company.
- c. The Company does not receive a copy of the dealer's invoice to the first registered owner within fourteen (14) days from the date of delivery.
- d. The Company has not been paid in full, by the dealer, for the Machine.

8. ACCIDENTS AND NORMAL MAINTENANCE

This limited warranty covers defective material and workmanship. It does not cover depreciation or damage caused by normal wear, accidents, improper maintenance, improper protection or improper use. The costs of normal maintenance or repairs for accidents or improper use, and related labor will be borne by the owner.

9. REPLACEMENT PARTS

BEFCO, Inc. warrants replacement parts to be free from defect in material and workmanship for a period of thirty (30) days from the date of delivery to the original purchaser.

WARRANTY REGISTRATION

BEFCO, Inc.
P.O. Box 6036
Rocky Mount, NC 27802-6036

Tel: (252) 977.9920 - Fax: (252) 977.9718

Dealer _____ Acct. # _____	Retail Customer _____
Street _____ Country _____	Street _____
Town _____ State _____ Zip _____	Town _____ State _____ Zip _____
Date of delivery _____ Invoice # _____	Phone _____
Model # _____ Serial # _____	
<p>Pre-Delivery Checklist:</p> <p><input type="checkbox"/> Oil in gearbox.</p> <p><input type="checkbox"/> Greased fittings.</p> <p><input type="checkbox"/> Safety guards in place.</p> <p><input type="checkbox"/> All hardware tight.</p> <p><input type="checkbox"/> Bolts torqued correctly.</p> <p><input type="checkbox"/> Attached unit to tractor. Yes/No.</p> <p><input type="checkbox"/> Field adjusted. Yes/No.</p> <p><input type="checkbox"/> Test run. Dry/Infield.</p> <p><input type="checkbox"/> Safety decals.</p> <p><input type="checkbox"/> Operator's Manual.</p> <p>The machine described above, had been prepared for delivery according to the Pre-Delivery Checklist and the Customer has been instructed in its care and operation and the condition of warranty.</p>	<p>Tractor make: _____</p> <p>Model: _____; HP _____</p> <p>Type of operation: Private homeowner, Landscaping, Commercial maintenance, Golf Course, Municipality, Turf Farm, others: _____</p> <p>Approximate number of acres machine will be used on annually: _____</p> <p>I hereby acknowledge that: I have received and accepted delivery of the machine described. The equipment was checked thoroughly for loose or missing parts and has been adjusted in accordance with the Pre-Delivery Checklist. I have read and understand the nature and extent of the warranty and understand clearly that there were and are no other representations of warranties either expressed or implied, made by anyone. I have been advised on proper operation, maintenance and lubrication procedure of this equipment. I have been instructed on and do understand the application, limitation and capacities this equipment was designed and recommended for, all as described in the Operator's Manual and literature published by the Company.</p>
Inspected by: _____	
Date: _____	Date: _____
Dealer's Signature: _____	Customer's Signature: _____

This registration along with a copy of the invoice must be sent to BEFCO, Inc. within 14 days of date of purchase.

Sender:

Fold here

*Place stamp
here*

BEFCO, Inc.

Warranty Department

P.O. Box 6036

Rocky Mount, NC 27802-6036

Cut along this line



BEFCO®

Parts Manual

TORNADO

Medium Duty Rotary Cutter

RMD-360, RMD-372

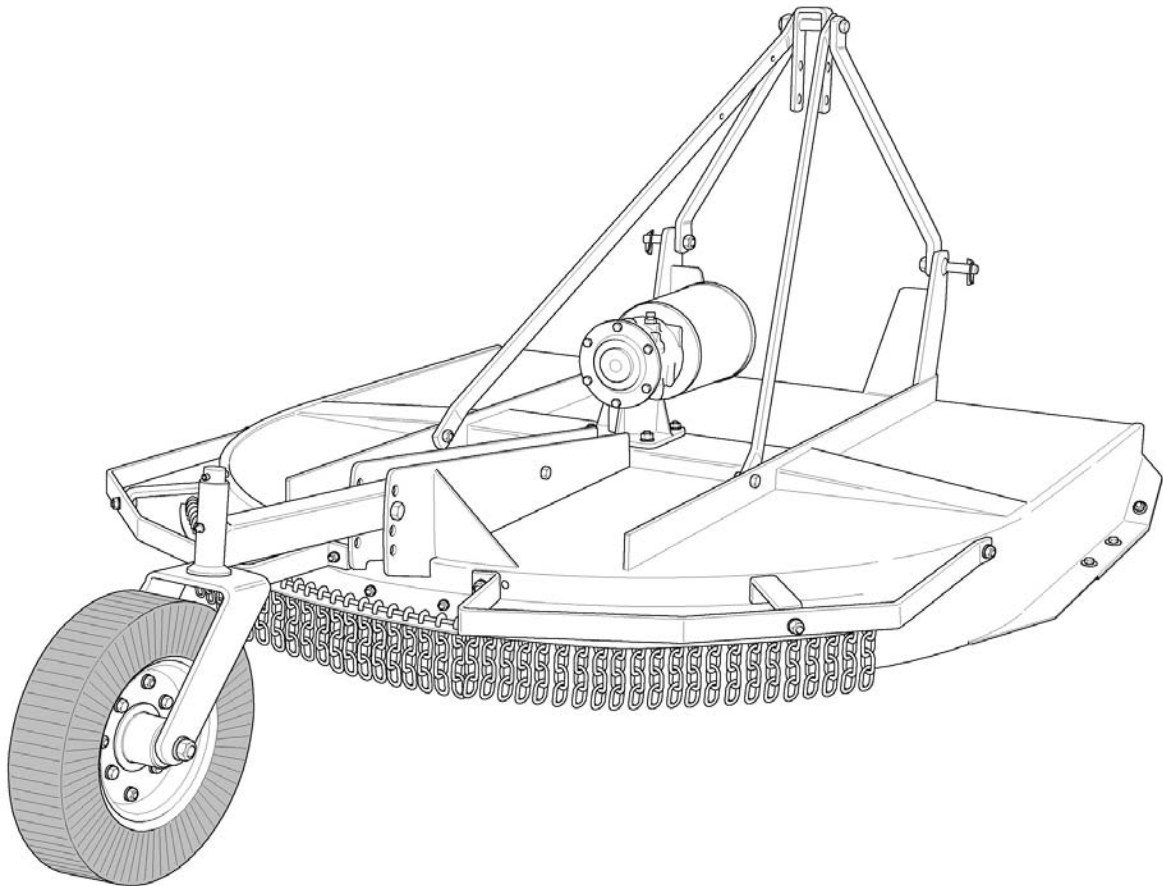

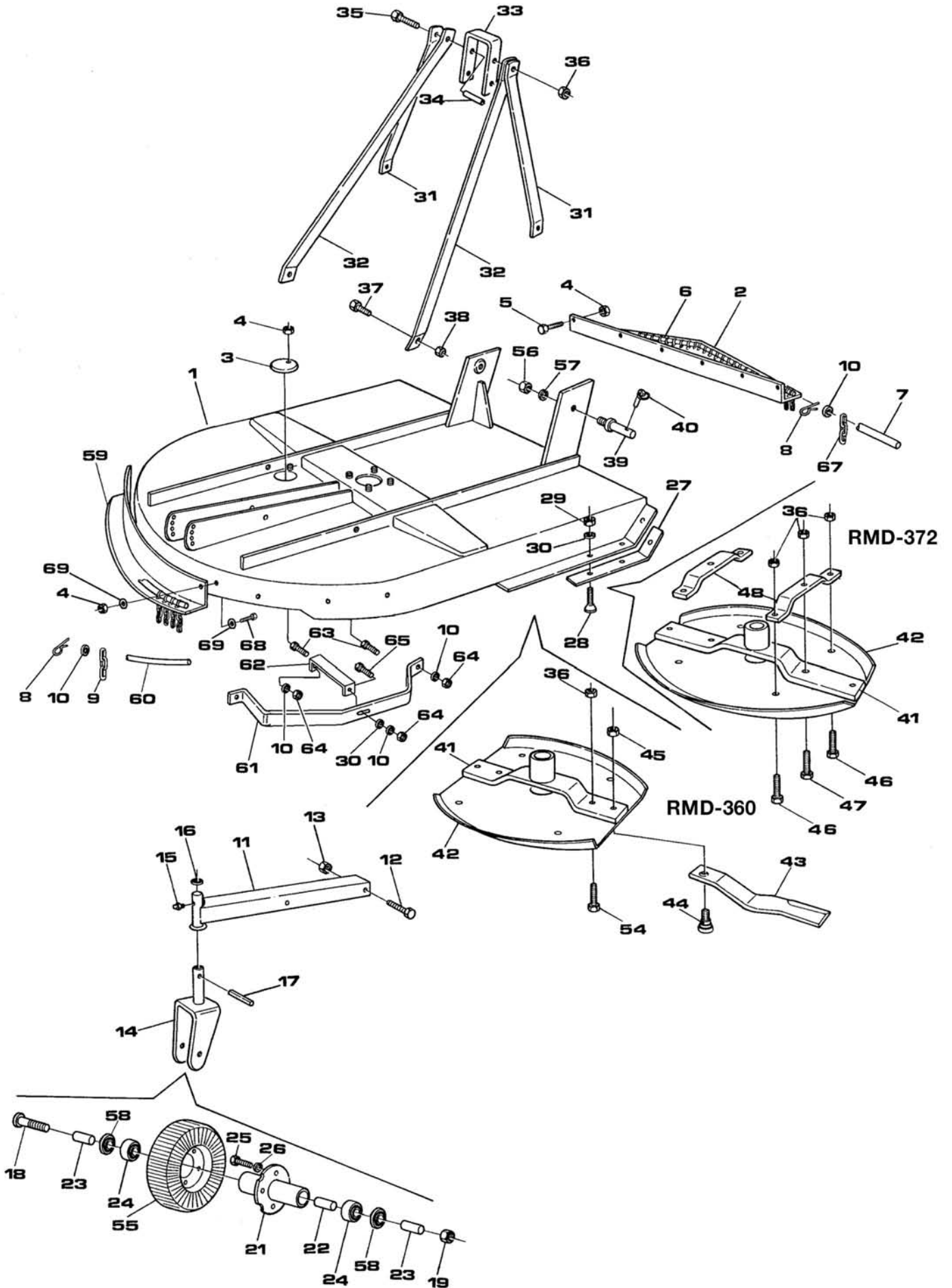

Ref.	Part #	Description	Qty.
1	016-0510	Frame 60"; RMD-360	1
	026-0510	Frame 72"; RMD-372	1
2	015-2715	Front shield; RMD-360	1
	026-0550	Front shield; RMD-372	1
3	000-5512	Cover	1
4	003-0156	Nut PT M10-1.50 C6 TK Z	-
5	000-6349	Bolt HH M10-1.50x20 C8.8 Z F	-
6	015-2718	Chain rod, short; RMD-360	1
	025-2718	Chain rod, short; RMD-372	1
7	015-2719	Chain rod, long; RMD-360	1
	025-2719	Chain rod, long; RMD-372	1
8	004-4156	Cotter pin Ø4x25	3
9	004-4158	Chain	-
10	000-1077	Washer lock Ø12 Z	14
11	000-5523	Wheel arm	1
12	000-6566	Bolt HH M16-2.00x100 C8.8 Z P	2
13	004-1165	Nut ES M16-2.00 Z TN	2
14	000-5531	Wheel yoke	1
15	000-1065	Grease fitting M10-1.00	1
16	004-4128	Shim Ø32	1
17	000-5521	Roll pin Ø10x45	1
18	000-5506	Bolt HH M20-2.50x180 C8.8 Z P	1
19	000-5508	Nut HH M20-2.50 C6 Z MD	1
21	005-2882	Hub, wheel; #296499 & below ¹⁴	1
	7900429	Hub, wheel; #296500 & above	1
22	005-2886	Wheel spacer, inner	1
23	005-2887	Wheel spacer, outer; #296499 & below	2
	7900428	Wheel spacer, outer; #296500 & above	2
24	005-2889	Bearing L44643-10	2
25	005-2891	Bolt HH 1/2"-20x1.00" G5 Z F	4
26	005-2892	Washer lock 1/2" Z	4
27	005-2709	Side skid	2
28	004-4023	Bolt CS M12-1.75x30 C10.9 Z F	6
29	003-0064	Nut PT M12-1.75 C6 TK Z	6
30	000-2265	Washer flat Ø12 W	6
31	006-0620	Top hitch support	2
32	016-0622	Top hitch arm; RMD-360	2
	026-0622	Top hitch arm; RMD-372	2
33	000-6828	Top hitch plate	1
34	000-6829	Spacer	1
35	000-6834	Bolt HH M16-2.00x150 C8.8 Z P	1
36	000-5581	Nut PT M16-2.00 C6 Z TK	-
37	000-1526	Bolt HH M14-2.00x35 C8.8 Z F	2
38	003-0358	Nut PT M14-2.00 C6 Z TK	2
39	006-0610	Hitch pin	2
40	001-8266	Lynch pin Ø11x45	2
41	015-2846	Rotor; RMD-360	1
	025-2846	Rotor; RMD-372	1

¹⁴ Interchangeable with wheel hub #7900429 provided outer wheel spacers #7900428 (qty. 2) are also ordered.

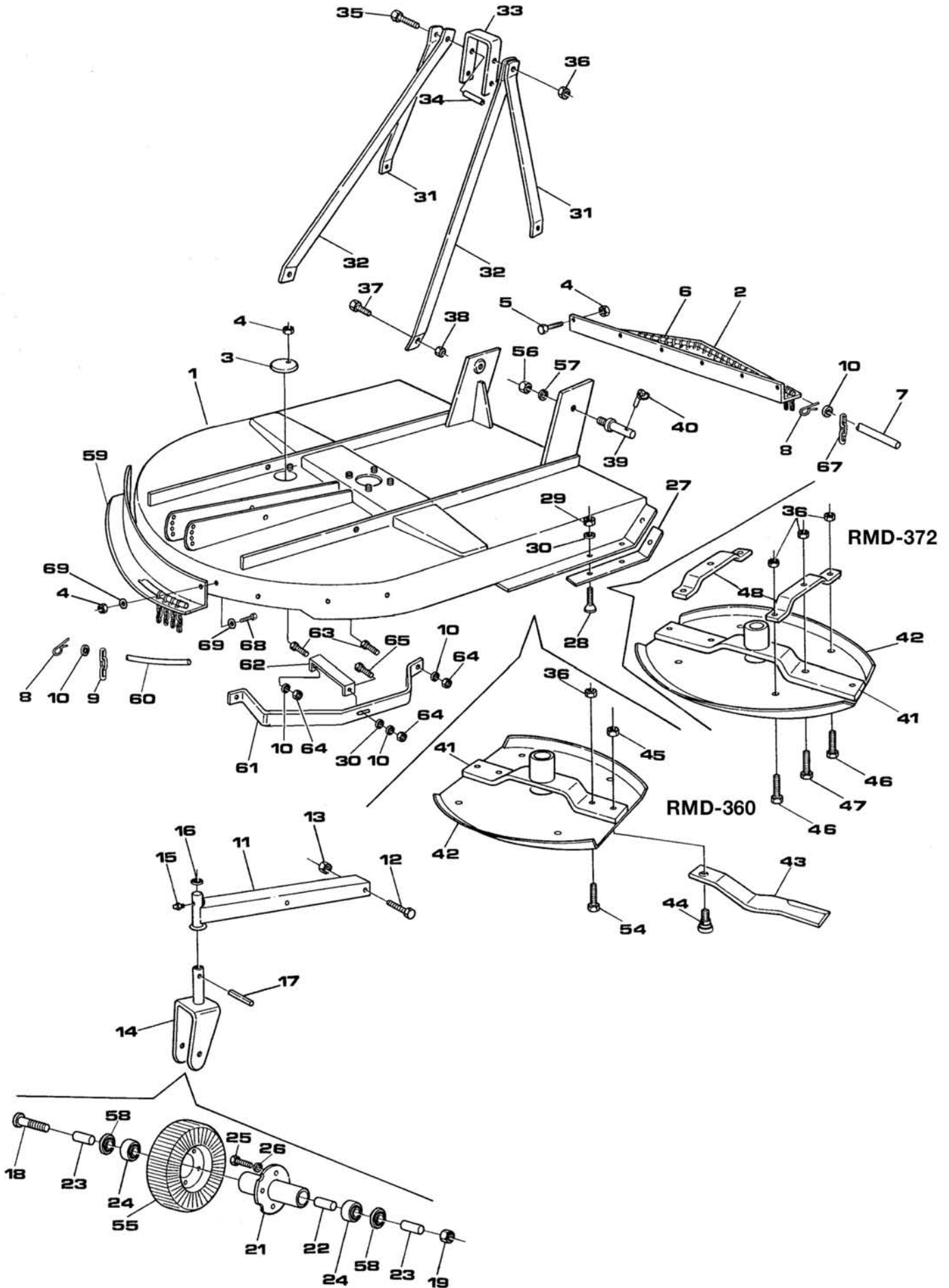

Ref.	Part #	Description	Qty.
42	005-2850	Protection, rotor; RMD-360	1
	008-5160	Protection, rotor; RMD-372	1
43	008-5152	Blade	2
44	005-2861	Bolt blade SP M27-2.00x72	2
45	000-5570	Nut ES M27-2.00 Z TN	2
46	008-5168	Bolt HH M16-2.00x30 C8.8 Z F	4
47	003-3218	Bolt HH M16-2.00x55 C8.8 Z P	2
48	005-2858	Fixing plate	2
54	000-2365	Bolt HH M16-2.00x50 C8.8 Z P	2
55	005-2895	Wheel, laminated	1
56	000-5542	Nut HH M20-1.50 C6 Z MD	2
57	000-5351	Washer lock Ø20 Z	2
58	005-2888	Oil seal 12194	2
59	016-0571	Protection, rear; RMD-360 #284653 & below ¹⁵	1
	016-0572	Protection, rear; RMD-360 #284654 & above	1
	026-0571	Protection, rear; RMD-372 #284653 & below ¹⁶	1
	026-0572	Protection, rear; RMD-372 #284654 & above	1
60	016-0576	Chain rod, rear; RMD-360 #284653 & below	1
	016-0577	Chain rod, rear; RMD-360 #284654 & above	1
	026-0576	Chain rod, rear; RMD-372 #284653 & below	1
	026-0577	Chain rod, rear; RMD-372 #284654 & above	1
61	016-0611	Protection, side; RMD-360	2
	026-0611	Protection, side; RMD-372	2
62	006-0616	Fixing plate	2
63	001-5255	Bolt HH M12-1.75x30 C8.8 Z F	6
64	000-3038	Nut HH M12-1.75 C6 TK Z	8
65	002-3265	Bolt HH M12-1.75x40 C8.8 Z F	2
67	006-0564	Chain	-
68	003-3176	Bolt HH M10-1.50x25 C8.8 Z F	6
69	000-2034	Washer flat Ø10 W	12
	950-109B	Decal "DANGER - Avoid injury from PTO"	1
	950-116B	Decal "DANGER - Rotating blades; Thrown objects"	2
	950-407B	Decal "WARNING - Crushing and pinching hazard"	1
	950-406B	Decal "WARNING - Falling off"	1
	950-111B	Decal "CAUTION - To avoid serious injury"	1
	950-366B	Decal, red reflective	2
	950-107B	Decal "BEFCO"	4
	950-104B	Decal "B"	1
	950-145B	Decal "Tornado"	1
	950-269B	Decal "RMD"	1
	950-442B	Decal "360"	-
	950-271B	Decal "372"	-
	950-381B	Decal "BEFCO INC." address	1
	971-396B	Operator's & Parts Manual "Tornado RMD-360, 372"	1

¹⁵ Interchangeable with protection #016-0572 provided chain rod #016-0577 is also ordered.

¹⁶ Interchangeable with protection #026-0572 provided chain rod #026-0577 is also ordered.

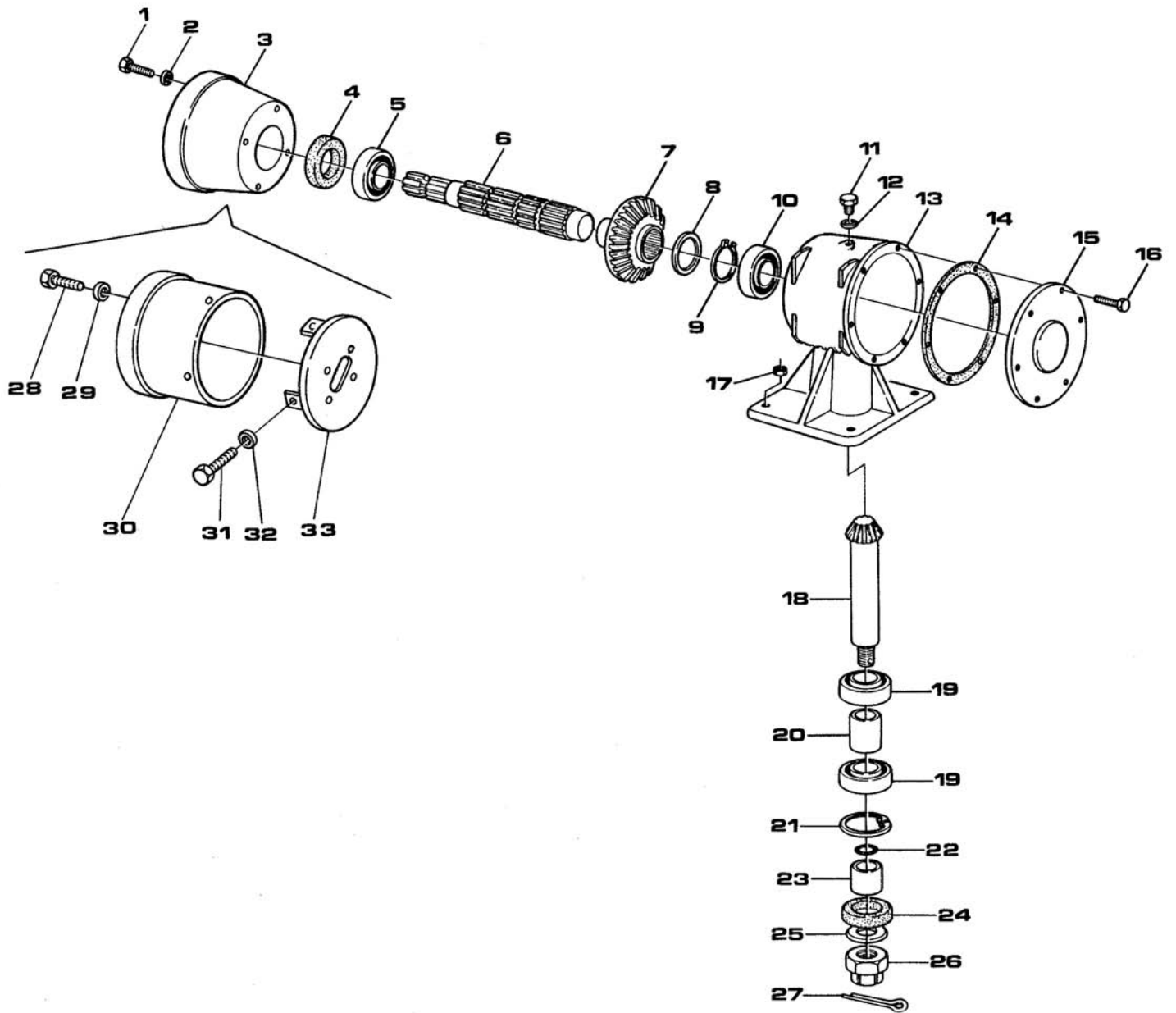

Ref.	Part #	Description	Qty.
1	009-2317	Bolt HH M10-1.50x16 C8.8 Z F	4
2	000-2034	Washer flat Ø10 W	4
3	000-8663	Protection, driveline w/o slip clutch	1
4	000-2295	Oil seal 35.62.10	1
5	000-7172	Bearing 30207	1
6	000-5556	Input shaft	1
7	005-2792	Ring gear	1
8	003-4196	Shim Ø35x45x2.5	1
9	004-2122	Snap ring, outer Ø35	1
10	004-4217	Bearing 30305	1
11	000-1107A	Breather cap	1
12	000-6691	Gasket	1
13	000-6998	Housing, gearbox	1
14	003-0193	Gasket 2/10	-
	013-0193	Gasket 5/10	-
15	000-6656	Cover, gearbox	1
16	000-6349	Bolt HH M10-1.50x20 C8.8 Z F	6
17	003-0064	Nut PT M12-1.75 C6 TK Z	4
18	005-2793	Pinion gear	1
19	001-2149	Bearing 6208	2
20	000-6687	Spacer	1
21	000-1154	Snap ring, inner Ø80	1
22	000-5630	Gasket OR 144	1
23	005-2808	Spacer	1
24	000-5578	Oil seal 55.80.10 BASL	1
25	006-6039	Washer flat Ø31 N	1
26	000-3055	Nut CA M30-2.00 C5 N TN	1
27	000-5638	Cotter pin Ø5x50	1
28	000-6349	Bolt HH M10-1.50x20 C8.8 Z F	4
29	003-0157	Washer fender Ø10 Z	4
30	001-1207	Protection, slip clutch	1
31	001-1210	Bolt PN M06-1.00x12 C4.6 Z F	4
32	001-1209	Washer fender Ø6 Z	4
33	001-1201	Protection support	1
	050-0644	Gearbox, complete ¹⁷	-

¹⁷ Fill using approx. 44 fl.oz. (1.4 qt.) of SAE 90W gear oil.

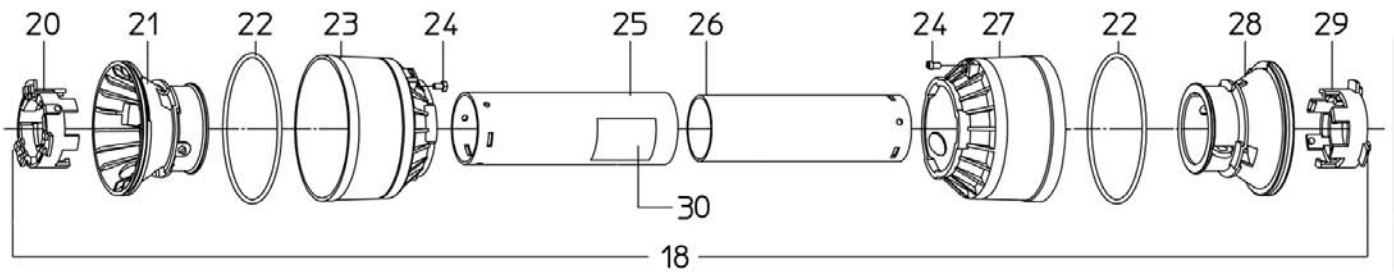
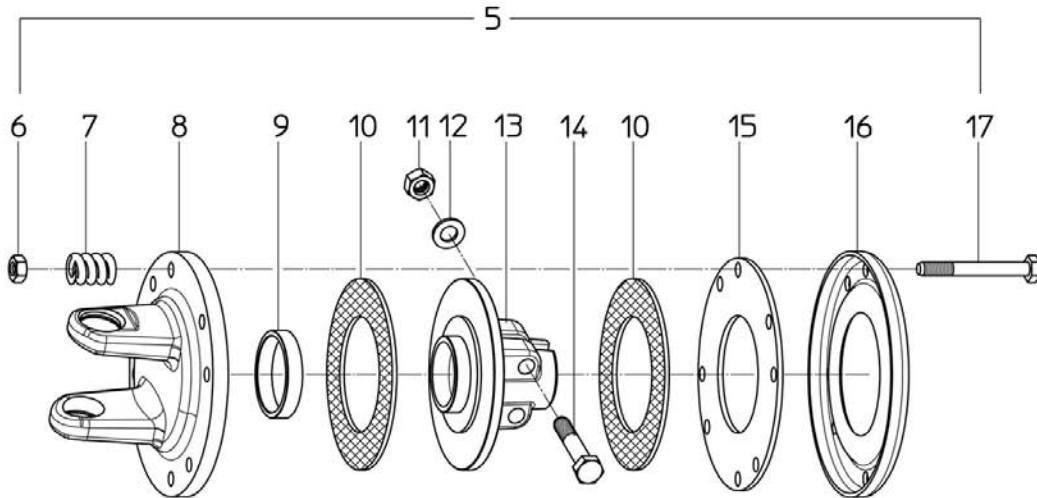
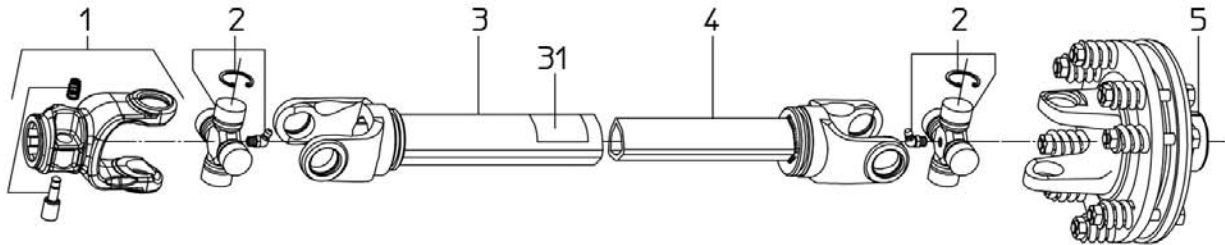

Ref.	Part #	Description	Qty.
1	1024010C	PTO yoke	1
2	1004020C	Cross & bearing	2
3	1944058NC	Outer tube; RMD-360	1
	1944073NC	Outer tube; RMD-372	1
4	1954060NC	Inner tube; RMD-360	1
	1954075NC	Inner tube; RMD-372	1
5	1334030C	Slip clutch, complete	1
6	003-0156	Nut PT M10-1.50 C6 ZC	8
7	1215012C	Spring	8
8	1704021C	Yoke, slip clutch	1
9	1704017C	Bushing	1
10	1804000C	Friction disc	2
11	000-1075	Nut HH M12-1.25 C6 ZC TK	2
12	000-1077	Washer lock Ø12 Z	2
13	1704016C	Body, slip clutch	1
14	003-4270	Bolt HH M12-1.25x65 C 8.8 Z P	2
15	1134008C	Inner disc	1
16	1134007C	Outer flange	1
17	001-5232	Bolt HH M10-1.50x75 C 8.8 Z P	8
18	90SC4056C	Shield, complete; RMD-360 ¹⁸	1
	90SC4071C	Shield, complete; RMD-372 ¹⁹	1
19	1006065C	Chain, anti-rotation	2
20	1784210C	Locking ring, outer tube; #284653 & below	1
21	1784201C	Rigid cone, outer tube; #284653 & below	1
22	1213233C	Stiffening ring; #284653 & below	2
23	1784203C	Standard cone; #284653 & below	1
24	1784212C	Pin; #284653 & below	2
25	1773056C	Shield, outer tube; RMD-360	1
	1773071C	Shield, outer tube; RMD-372	1
26	1872056C	Shield, inner tube; RMD-360	1
	1872071C	Shield, inner tube; RMD-372	1
27	1784204C	Short cone; #284653 & below	1
28	1784202C	Rigid cone, inner tube; #284653 & below	1
29	1784211C	Locking ring, inner tube; #284653 & below	1
30	950-463B	Decal "DANGER - Rotating driveline, keep away", outer shield	1
31	950-464B	Decal "DANGER - Guard missing, do not operate", outer tube	1
	050-0428	Driveline w/slip clutch, complete; RMD-360	-
	050-0429	Driveline w/slip clutch, complete; RMD-372	-

¹⁸ Complete shield is interchangeable with part #96SE4056C. Single shield components are not interchangeable.

¹⁹ Complete shield is interchangeable with part #96SE4071C. Single shield components are not interchangeable.

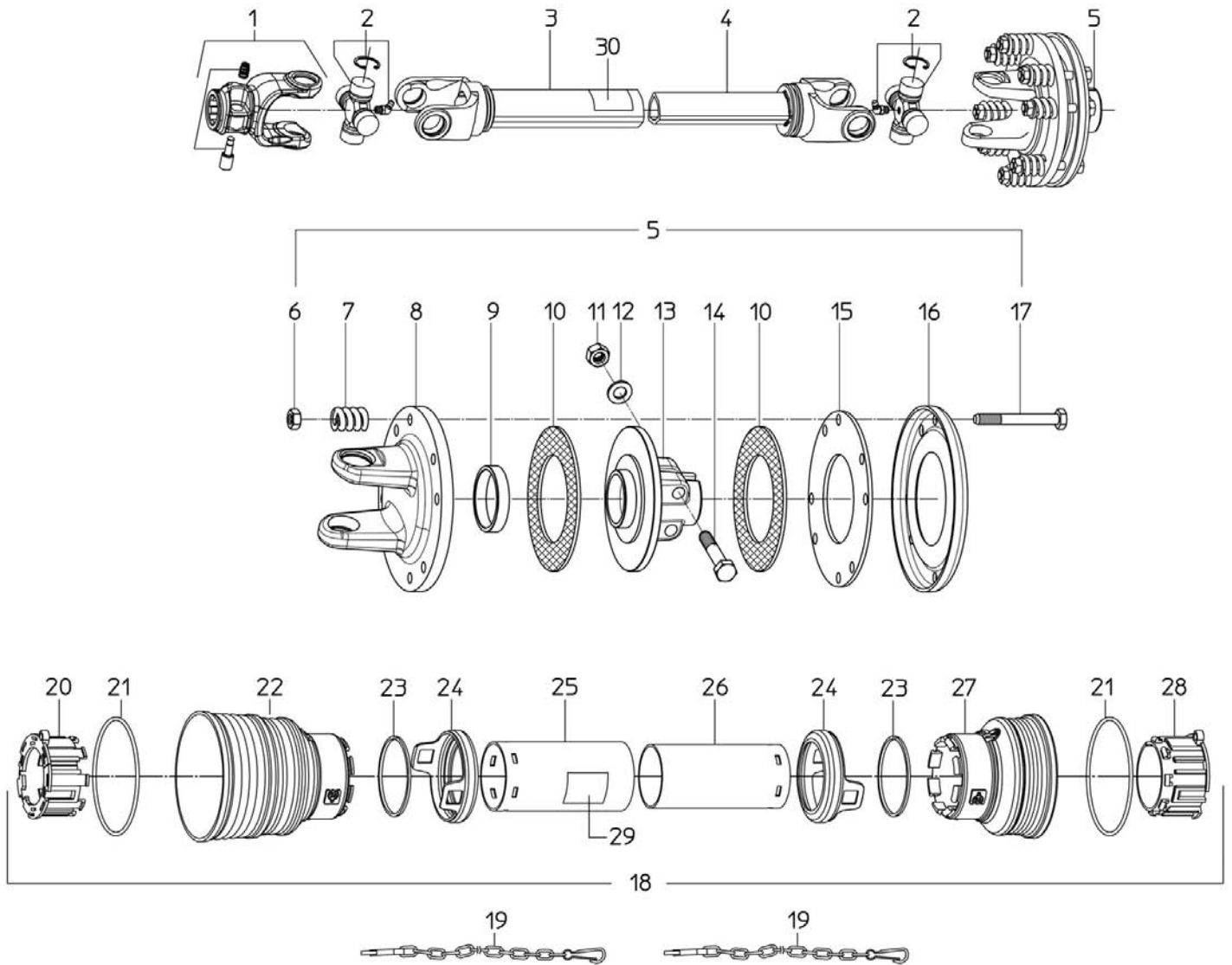

Ref.	Part #	Description	Qty.
1	1024010C	PTO yoke	1
2	1004020C	Cross & bearing	2
3	1944058NC	Outer tube; RMD-360	1
	1944073NC	Outer tube; RMD-372	1
4	1954060NC	Inner tube; RMD-360	1
	1954075NC	Inner tube; RMD-372	1
5	1334030C	Slip clutch, complete	1
6	003-0156	Nut PT M10-1.50 C6 Z	8
7	1215012C	Spring	8
8	1704021C	Yoke, slip clutch	1
9	1704017C	Bushing	1
10	1804000C	Friction disc	2
11	000-1075	Nut HH M12-1.25 C6 ZC TK	2
12	000-1077	Washer lock Ø12 Z	2
13	1704016C	Body, slip clutch	1
14	003-4270	Bolt HH M12-1.25x65 C 8.8 Z P	2
15	1134008C	Inner disc	1
16	1134007C	Outer flange	1
17	001-5232	Bolt HH M10-1.50x75 C 8.8 Z P	8
18	96SE4056C	Shield, complete; RMD-360	1
	96SE4071C	Shield, complete; RMD-372	1
19	1006065C	Chain, anti-rotation	2
20	1784710C	Locking ring, outer tube; #284654 & above	1
21	1211733C	Stiffening ring; #284654 & above	2
22	1781703C	Standard cone; #284654 & above	1
23	1211735C	Stop ring; #284654 & above	2
24	1881709C	Safety sleeve; #284654 & above	2
25	1773056C	Shield, outer tube; RMD-360	1
	1773071C	Shield, outer tube; RMD-372	1
26	1872056C	Shield, inner tube; RMD-360	1
	1872071C	Shield, inner tube; RMD-372	1
27	1781701C	Extra short cone; #284654 & above	1
28	1784711C	locking ring, inner tube; #284654 & above	1
29	950-463B	Decal "DANGER - Rotating driveline, keep away", outer shield	1
30	950-464B	Decal "DANGER - Guard missing, do not operate", outer tube	1
	050-0428	Driveline w/slip clutch, complete; RMD-360	-
	050-0429	Driveline w/slip clutch, complete; RMD-372	-

Use only original spare parts

All rights reserved. It is unlawful to copy, reprint or use any of the information or details in this manual without the expressed written permission of the Company. Technical information provided in this manual is approximate, the Company reserves the right to modify or improve the models shown for technical or commercial purposes. Pictures in this manual do not necessarily show the machine as delivered.

BEFCO[®]

P.O. Box 6036
Rocky Mount, NC 27802-6036
Tel.: 252.977.9920 - Fax: 252.977.9718
www.befco.com

