

BEFCO[®]

Operator's Manual

TILL-RITE

Side-Shift Rotary Tiller

T50-250, 350

T50-258, 358

T50-266, 366

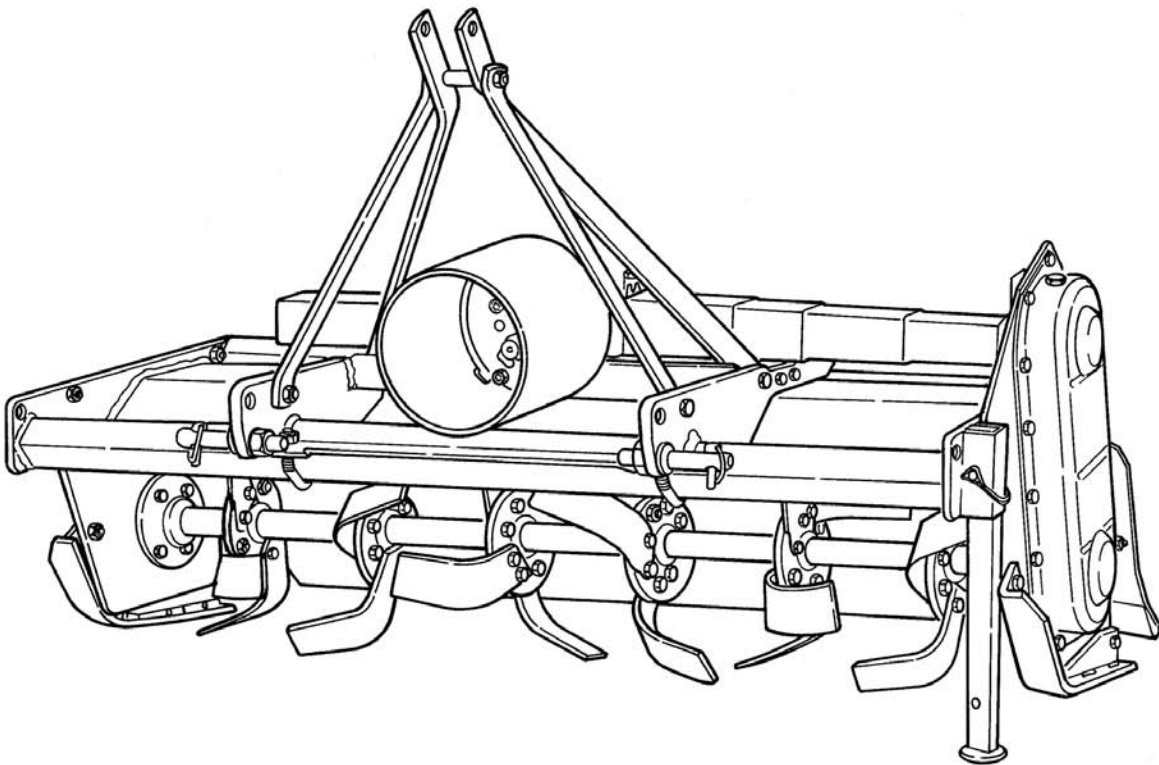

The operator's manual is a technical service guide and must always accompany the machine.

Manual 971-102B

December 2020

SAFETY

Take note! This safety alert symbol found throughout this manual is used to call your attention to instructions involving your personal safety and the safety of others. Failure to follow these instructions can result in injury or death.



*This symbol means:
ATTENTION!
BECOME ALERT!
YOUR SAFETY IS INVOLVED!*

Signal Words

Note the use of the signal words DANGER, WARNING and CAUTION with the safety messages. The appropriate signal words for each have been selected using the following guidelines:



DANGER: Indicates an imminently hazardous situation that, if not avoided, will result in death or serious injury.



WARNING: Indicates a potentially hazardous situation that, if not avoided, could result in death or serious injury, and includes hazards that are exposed when guards are removed. It may also be used to alert against unsafe practices.



CAUTION: Indicates a potentially hazardous situation that, if not avoided, may result in minor or moderate injury.

INDEX

1 - GENERAL INFORMATION	4
1.01 - General	4
1.02 - Warranty Information	4
1.03 - Model and Serial Number ID	5
2 - SAFETY PRECAUTIONS	6
2.01 - Preparation	6
2.02 - Starting and Stopping	7
2.03 - Messages and Signs	7
3 - OPERATION	10
3.01 - Operational Safety	10
3.02 - Setup and Lubrication	12
3.03 - Side-Shift	15
3.04 - Depth Control	17
3.05 - Rear Shield Adjustments	18
3.06 - Pre-Operational Check	18
3.07 - Attaching to the Tractor	19
3.08 - Start Up	21
3.09 - Test Run	22
3.10 - Working Depth	22
3.11 - Working Speed	23
3.12 - Finer Pulverization	23
3.13 - Headland Procedure	23
3.14 - Working Limitations	23
3.15 - Uneven Terrain	23
3.16 - Transport	24
4 - MAINTENANCE	25
4.01 - Maintenance Safety	25
4.02 - Lubrication	26
4.03 - Blade Maintenance	26
4.04 - Driveline	27
4.05 - Safety Shear Bolt	29
4.06 - Safety Slip Clutch	29
5 - REPAIR PROCEDURES	32
5.01 - Gearbox	32
5.02 - Chain Case	32
5.03 - Rotor	32
5.04 - Suggested Spare Parts	33
5.05 - Storage	33
6 - TROUBLESHOOTING	34
7 - PRE-DELIVERY CHECKLIST	35
8 - WARRANTY	36
PARTS MANUAL	41

1 - GENERAL INFORMATION

Thank you and congratulations for having chosen our implement. Your new side-shift rotary tiller is a technologically advanced machine constructed of high quality, sturdy components that will fulfill your working expectations.

Read this manual carefully. It will instruct you on how to operate and service your machine safely and correctly. Failure to do so could result in personal injury and/or equipment damage.

1.01 - General

The implement described in this manual is to be used with tractors with PTO at 540 rpm and clockwise rotation.



CAUTION: Always ensure that the coupling of the implement with the tractor is done at the same PTO speed and direction of rotation. Do not operate this implement at a PTO speed or direction of rotation other than that shown on the implement. Serious damage can occur to the machine and/or the operator.



CAUTION: Unless otherwise specified, all hardware is metric. Use only metric tools on metric hardware. Other tools that do not fit properly can slip and cause injury.



CAUTION: Right hand and left hand sides of the implement are determined by facing in the direction the implement will travel when going forward (see fig. 2).

1.02 - Warranty Information

Carefully read the Warranty section¹, detailing coverage and limitations of this warranty. **Warranty** is provided for customers who operate and maintain their equipment as described in this manual. Warranty registration is accomplished by the dealer by completing and forwarding the **Warranty Registration** form to the Company, along with a copy of the dealer's invoice. It is in your best interest to insure that this has been done.

Warranty does not cover the following:

1. Cleaning, transporting, mailing and service call charges.

¹ See Chapter 8 - Warranty.

2. Normal wear items such as blades, bearings, drivelines, shear bolts, slip clutches, etc.
3. Depreciation or damage caused by normal wear, accidents, improper maintenance, improper protection or improper use.
4. The use of non-original spare parts and accessories.

Your Authorized Company Dealer has genuine parts in stock. Only these approved replacement parts should be used.

This limited warranty covers defective material and workmanship. The cost of normal maintenance or repairs for accidents or improper use and related labor will be borne by the owner.

1.03 - Model and Serial Number ID

Attached to the frame is an ID plate showing the model and the serial number. Record your implement model and serial number in the space provided below. Your local dealer needs this information to give you prompt, efficient service when you order parts.

BEFCO	1781 S. Wesleyan Blvd. – P.O. Box 6036 Rocky Mount, N.C. 27802 – U.S.A. Tel: 1.252.977.9920 Fax: 1.252.977.9718
MODEL:	
SERIAL:	
VERSION:	

2 - SAFETY PRECAUTIONS

Safety is the primary concern in the design and manufacture of our products. Unfortunately our efforts to provide safe equipment can be wiped out by a single careless act of an operator.

In addition to the design and configuration of equipment, hazard control and accident prevention are dependent upon the awareness, concern, prudence and proper training of personnel involved in the operation, transport, maintenance and storage of equipment.

It is the operator's responsibility to read and understand all safety and operating instructions in the manual and to follow these.

Allow only properly trained personnel to operate the rotary tiller. Working with unfamiliar equipment can lead to careless injuries. Read this manual, and the manual for your tractor, before assembly or operation, to acquaint yourself with the machines. It is the tiller owner's responsibility, if this machine is used by any person other than yourself, is loaned or rented, to make certain that the operator, prior to operating, reads and understands the operator's manuals and is instructed in safe and proper use.

2.01 - Preparation



1. Before operating equipment read and understand the operator's manual and the safety signs (**see fig. 2**).
2. Thoroughly inspect the implement before initial operation to assure that all packaging materials, i.e., wires, bands, and tape have been removed.
3. Personal protection equipment including hard hat, safety glasses, safety shoes, and gloves are recommended during assembly, installation, operation, adjustment, maintaining and/or repairing the implement.
4. Operate the tiller only with a tractor equipped with an approved Roll-Over-Protective-System (ROPS). Always wear your seat belt. Serious injury or even death could result from falling off the tractor.
5. Clear area of stones, branches or other debris that might be thrown, causing injury or damage.
6. Operate only in daylight or good artificial light.
7. Ensure tiller is properly mounted, adjusted and in good operating condition.
8. Ensure that all safety shielding and safety signs are properly installed and in good condition.
9. Consult local utility companies to make certain there are no buried gas lines, electrical cables, etc., in the work area before beginning operation.

2.02 - Starting and Stopping



1. Be sure that no one is near the machine prior to engaging or while the machine is working.
2. Be sure the tractor is in "Neutral" before starting engine.
3. Tiller operating power is supplied from tractor PTO. Refer to your tractor manual for PTO engagement and disengagement instructions. Always operate PTO at 540 rpm. Know how to stop the tractor and tiller quickly in case of an emergency.
4. When engaging PTO, the engine rpm should always be low. Once engaged and ready to start using, raise PTO speed to 540 rpm and maintain throughout operation.
5. Check the tractor master shield over the PTO stub shaft. Make sure it is in good condition and fastened securely to the tractor. Purchase a new shield if old shield is damaged or missing.
6. After striking an obstacle, disengage the PTO, shut the tractor down and thoroughly inspect for damage before restarting.
7. Never engage the PTO until the tiller is in the down position and resting on the ground. Never raise the tiller until the rotor has come to a complete stop.

2.03 - Messages and Signs



1. Read and adhere to all safety and operating decals on this machine (**see fig. 2**).
2. Before dismounting tractor: Allow moving parts to stop, stop engine, set brake and remove the key of unattended equipment.
3. Keep away from rotating blades and driveline.
4. Keep guards and shields in place and in good condition.
5. Do not use with bystanders in area.
6. Allow no riders on tractor or tiller.
7. Allow moving parts to stop before repair.
8. Securely support tiller before working underneath.

Additional warning and operating decals are available at no extra charge. Please specify model and serial number when ordering.

Fig. 2 - Safety decals - implement; replace immediately if damaged.

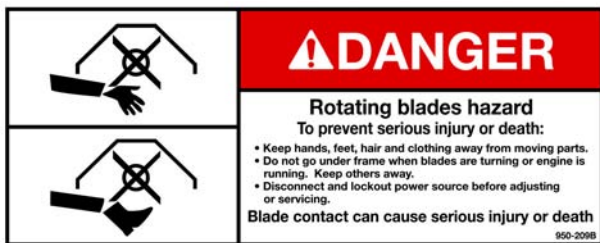
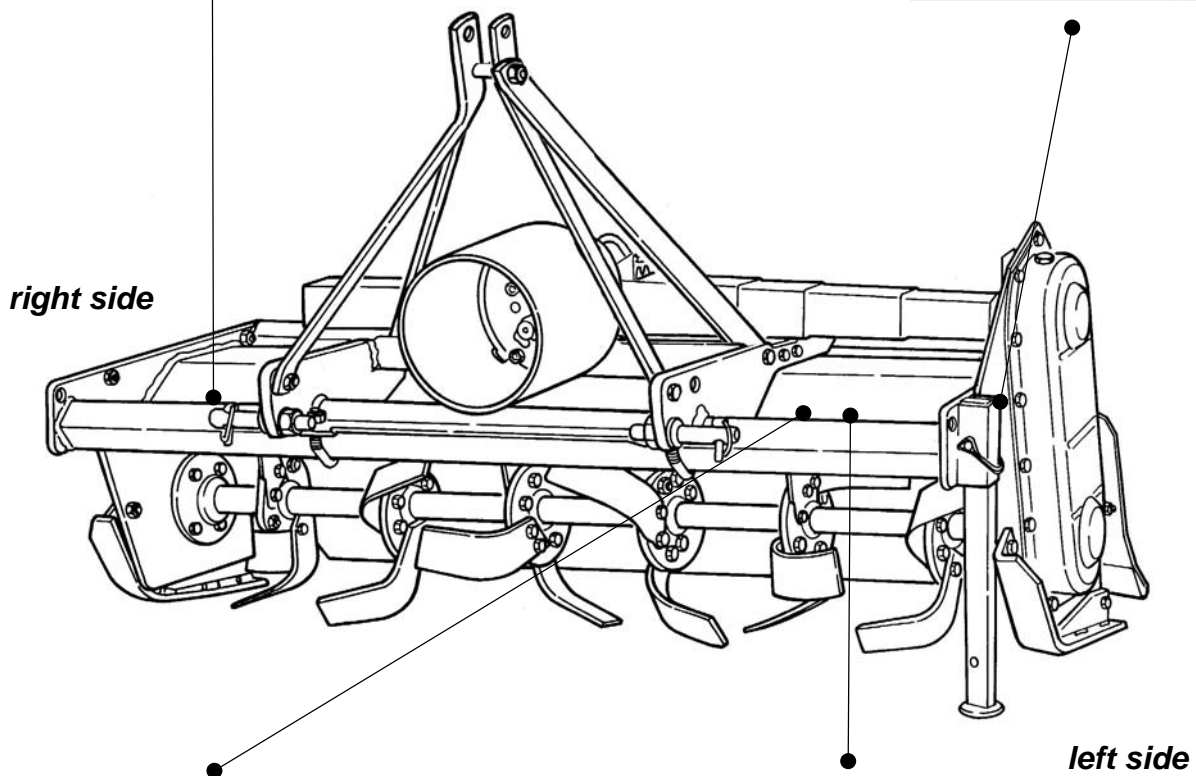

Safety decals - driveline; replace immediately if damaged.

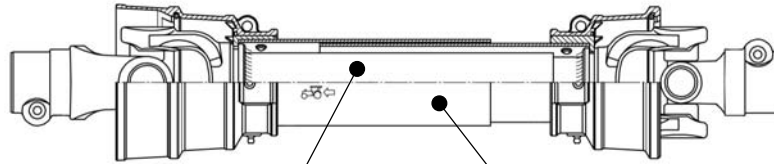

placed on outer tube



placed on outer shield

3 - OPERATION

You have purchased a rotary tiller designed for landscaping, gardening and tilling with small and medium sized tractors around fruit trees and in vineyards or greenhouses. Because of its side-shift capability, your tiller can be positioned to till next to trees and shrubs and along sidewalks. It can also be shifted completely to the right in order to cover the tractor tire tracks. This is particularly important when dealing with narrower tillers or with tractors equipped with especially wide tires. The three point hitch can also remain positioned in the center to work like a normal center mount tiller. On your tiller, the tractor PTO transmits its power through a driveline to a speed reduction gearbox. This gearbox turns a hexagonal drive shaft to which a chain sprocket is attached. A chain transfers power from the drive chain sprocket to a driven chain sprocket connected to a tilling bladed rotor. The rotor speed is set at the optimum speed to ensure ideal tillage conditions.

3.01 - Operational Safety



CAUTION: Our rotary tillers are designed considering safety as the most important target and are the safest available in today's market. Unfortunately, human carelessness can override the safety features built into our machines. Injury prevention and work safety, aside from the features on our tillers, are very much due to the responsible use of the equipment. It must always be operated prudently following with great care, the safety instructions laid out in this manual.



1. The use of this equipment is subject to certain hazards which cannot be prevented by mechanical means or product design. All operators of this equipment must read and understand this entire manual, paying particular attention to safety and operating instructions, prior to using.
2. Do not operate the tractor and tiller when you are tired, sick or when using medication.
3. Before beginning operation, contact local utility companies to make certain there are no bundled gas lines, electrical cables, etc., in the work area.
4. Keep all helpers and bystanders at least 50 yards from a tiller. Only properly trained people should operate this machine.
5. When this machine is operated in populated areas where thrown objects could injure persons or property, standard equipment safety shielding (which is designed to reduce the possibility of thrown objects) must be installed.
6. The majority of accidents involve entanglements on the driveline, injury of bystanders by objects thrown by the rotating blades, and operators being knocked

- off the tractor by low hanging limbs and then being run over by the tiller. Accidents are most likely to occur with machines that are loaned or rented to someone who has not read the operator's manual and is not familiar with a tiller.
7. Always stop the tractor, set brake, shut off the tractor engine, remove the ignition key, lower implement to the ground and allow rotor to come to a complete stop before dismounting tractor. Never leave equipment unattended with the tractor running.
 8. Never place hands or feet under tiller's deck with tractor engine running or before you are sure all motion has stopped. Stay clear of all moving parts.
 9. Do not allow riders on the tiller or tractor at any time. There is no safe place for riders.
 10. Do not operate unless all personnel, livestock and pets are 50 yards away to prevent injury by thrown objects.
 11. Before backing up, disengage the tiller and look behind carefully.
 12. Install and secure all guards and shields before starting or operating.
 13. Keep hands, feet, hair and clothing away from moving parts.
 14. This tiller is designed for use only on tractors with 540 rpm power take off and in the correct power range².
 15. Never operate tractor and tiller under trees with low hanging limbs. Operators can be knocked off the tractor and then run over by the rotor.
 16. The rotating parts of this machine have been designed and tested for rugged use. However, they could fail upon impact with heavy, solid objects such as steel guard rails and concrete abutments. Such impact could cause the broken objects to be thrown outward at very high velocities. To reduce the possibility of property damage, serious injury, or even death, never allow the rotor to contact such obstacles.
 17. Frequently check blades. They should be sharp, free of nicks and cracks and securely fastened.
 18. Stop tiller immediately upon striking an obstruction. Turn engine off, remove key, inspect and repair any damage before resuming operation.
 19. Stay alert for holes, rocks and roots in the terrain and other hidden hazards. Keep away from drop-offs.
 20. Use extreme care and maintain minimum ground speed when transporting on hillside, over rough ground and when operating close to ditches or fences. Be careful when turning sharp corners.
 21. Reduce speed on slopes and sharp turns to minimize tipping or loss of control. Be careful when changing directions on slopes. Do not start or stop suddenly on slopes. Avoid operation on steep slopes.
 22. When using a unit, a minimum 20% of tractor and equipment weight must be on tractor front wheels. Without this weight, tractor could tip over, causing personal injury or death. The weight may be attained with a front end loader, front wheel weights, ballast in tires or front tractor weights. When attaining a minimum 20% of tractor and equipment weight on the front wheels, you must not exceed the ROPS weight certification. Weigh the tractor and equipment. Do not guess or estimate!

² See Table 3, page 31.

23. Inspect the entire machine periodically³. Look for loose fasteners, worn or broken parts, and leaky or loose fittings.
24. Use only the driveline supplied with the equipment. Do not use it if it is missing any shield or safety protection.
25. Pass diagonally through sharp dips and avoid sharp drops to prevent "hanging up" tractor and implement.
26. Avoid sudden starts and stops while traveling up or downhill.
27. Always use down slopes; never across the face. Avoid operation on steep slopes. Slow down on sharp turns and slopes to prevent tipping and/or loss of control.

3.02 - Setup and Lubrication

Notice to the dealer: Pre-delivery setup and service including lubrication is the responsibility of the dealer. It is up to him to assure that the machine is in perfect condition and ready to be used. It is his responsibility to ensure that the customer is aware of all safety aspects and operational procedures for the tiller. He must also fill out the Pre-Delivery Checklist⁴ prior to delivering the tiller.

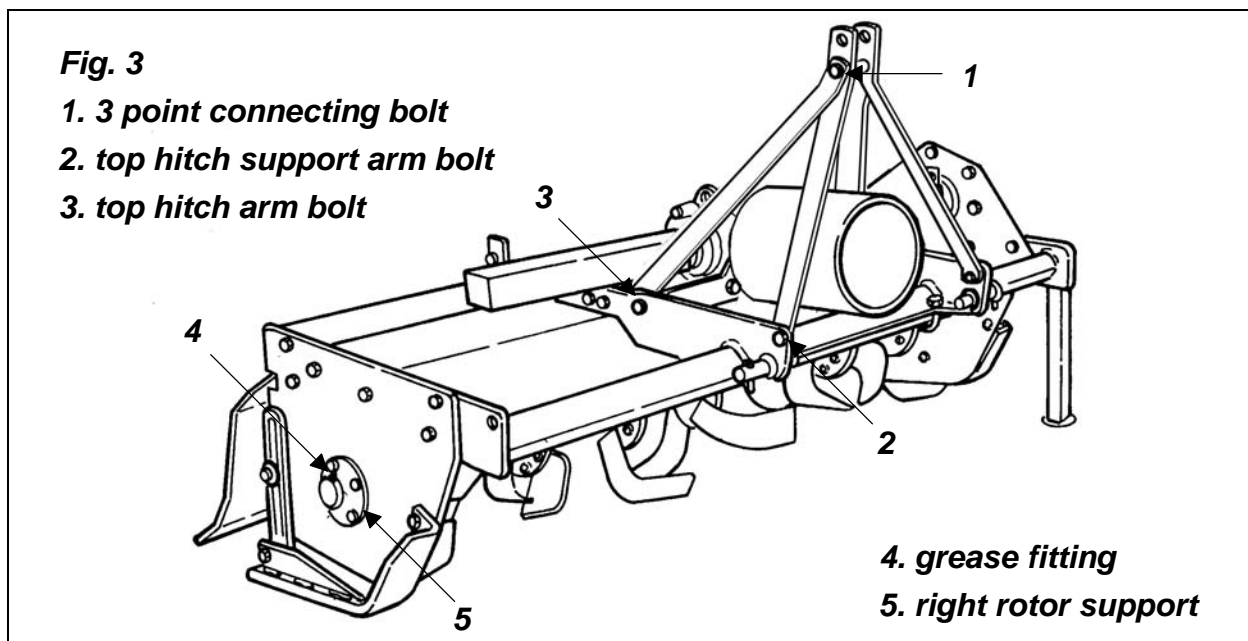

CAUTION: Stand clear of bands when cutting as they could be under sufficient tension to cause them to fly loose. Take care in removing bands and wire, they often have extremely sharp edges and cut very easily.

³ See Chapter 4 - Maintenance.

⁴ See Chapter 7 - Pre-Delivery Checklist.

To assemble and setup the tiller for initial operation proceed as follows:

1. Lower the stand to support the tiller (**see fig. 4**). Secure it in place with the locking pin.

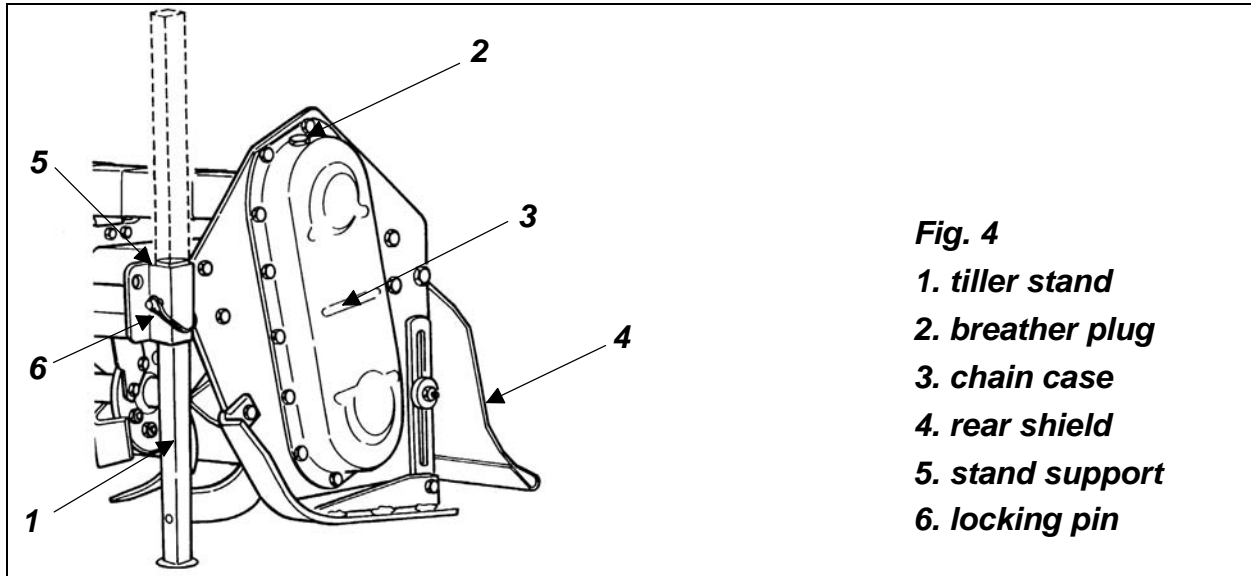

Fig. 4

1. tiller stand
2. breather plug
3. chain case
4. rear shield
5. stand support
6. locking pin

2. Disassemble top and sides of the crate. Cut wires holding driveline. Leave machine banded to pallet as long as possible to avoid tipping over during assembly.
3. Assemble the hitch together loosely (**see fig. 3**), and bolt it to the tiller.
4. Ensure the breather plug (**see #2, fig. 4**) is screwed into the chain case (**see #3, fig. 4**). Check the gearbox oil level (**see #1, fig. 5**). It should be approximately half full. If needed add SAE 90W gear oil.

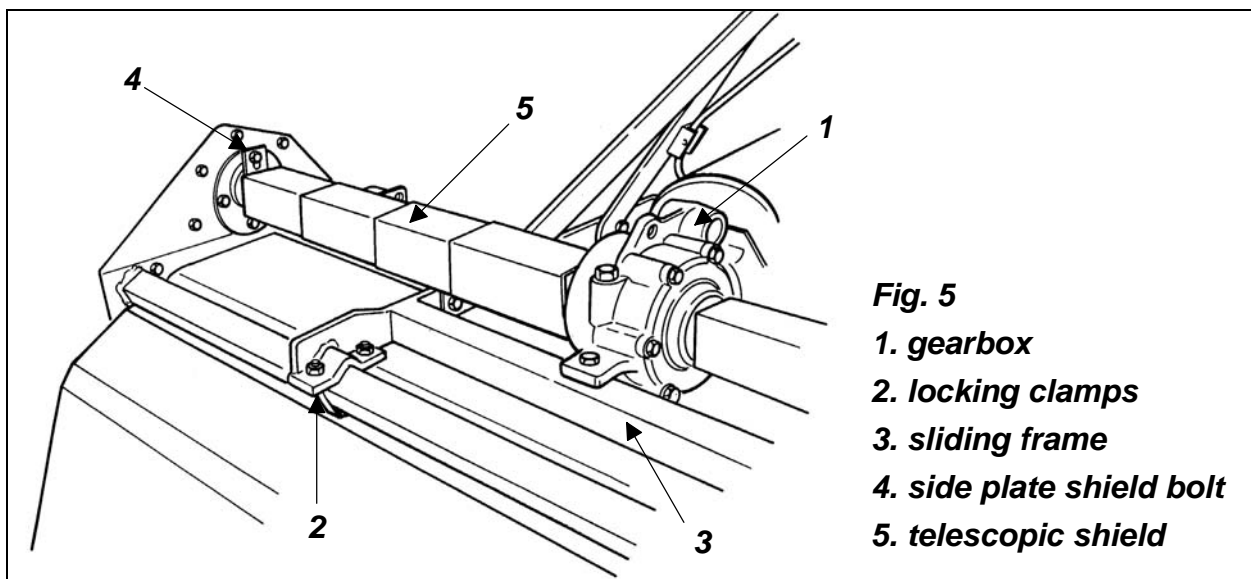

Fig. 5

1. gearbox
2. locking clamps
3. sliding frame
4. side plate shield bolt
5. telescopic shield

5. Check all hardware for proper torque⁵.

⁵ See Table 2, page 31 for proper torque specification.

6. After shifting the sliding frame into its desired position, block it with both the front and rear locking clamps U bolts (**see #2, fig. 5**)⁶. Grease driveline cross and bearing assemblies. Grease sliding sections of shaft.
7. The hexagonal drive shaft is protected by a telescopic sliding shield (**see #5, fig. 5**). To attach this shield do the following: bolt the upright tab to the chain case side plate (**see #4, fig. 5**); open the telescopic shield and bolt the outer cover to the retaining plate on the sliding frame (**see #1, fig. 6**); ensure the telescopic shielding when open does not touch the hexagonal shaft and is parallel as possible; slide the frame back two or three times from completely open to completely closed to be sure it opens and closes without difficulty. Note: Lightly greasing the hexagonal drive shaft helps to side-shift the tiller.

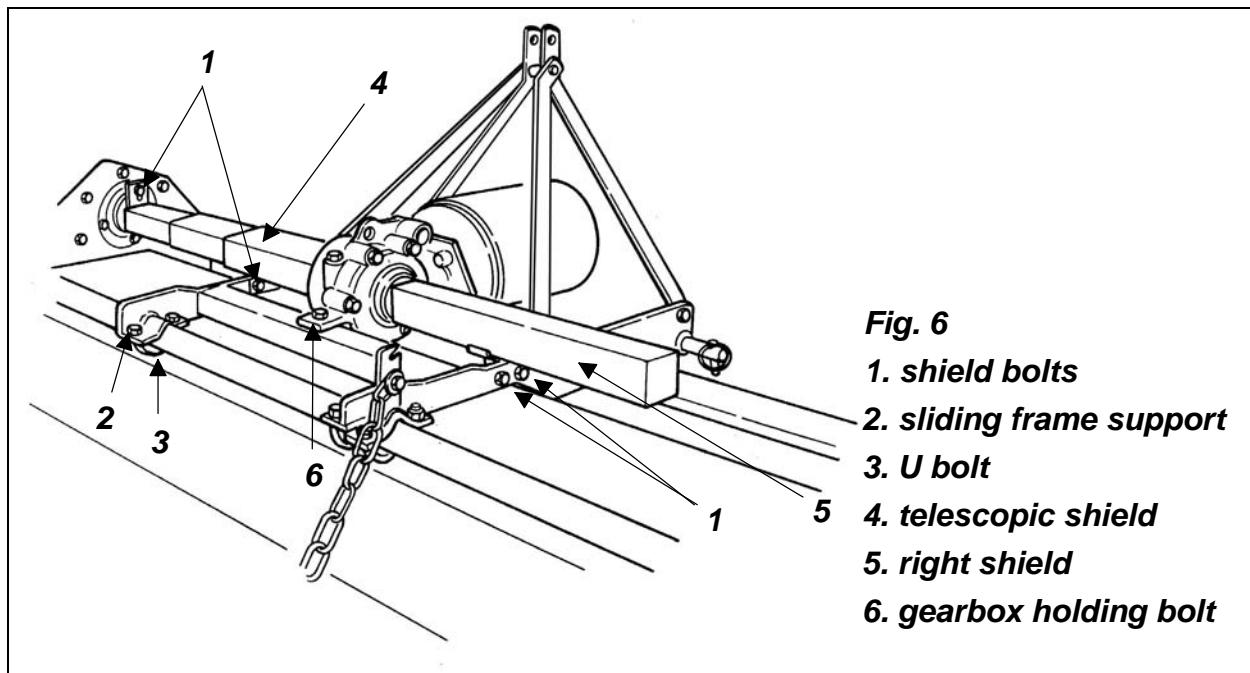

8. Grease right rotor support bearing (**see #4 & 5, fig. 3**).
9. Hook up the rear shield (**see #1, fig. 7**) adjustment chain as follows: slip one end of the chain (**see #2, fig. 7**) through the 'U' bolt (**see #3, fig. 7**) and then bolt it to the rear shield in the predisposed holes. Bolt the other end of the chain to the chain hitch located on the tiller frame (**see #4, fig. 7**). Ensure it is tightened properly. The chain hitch also works as a stop for the sliding frame to limit its travel.

⁶ See Section 3.03 - Side-Shift.

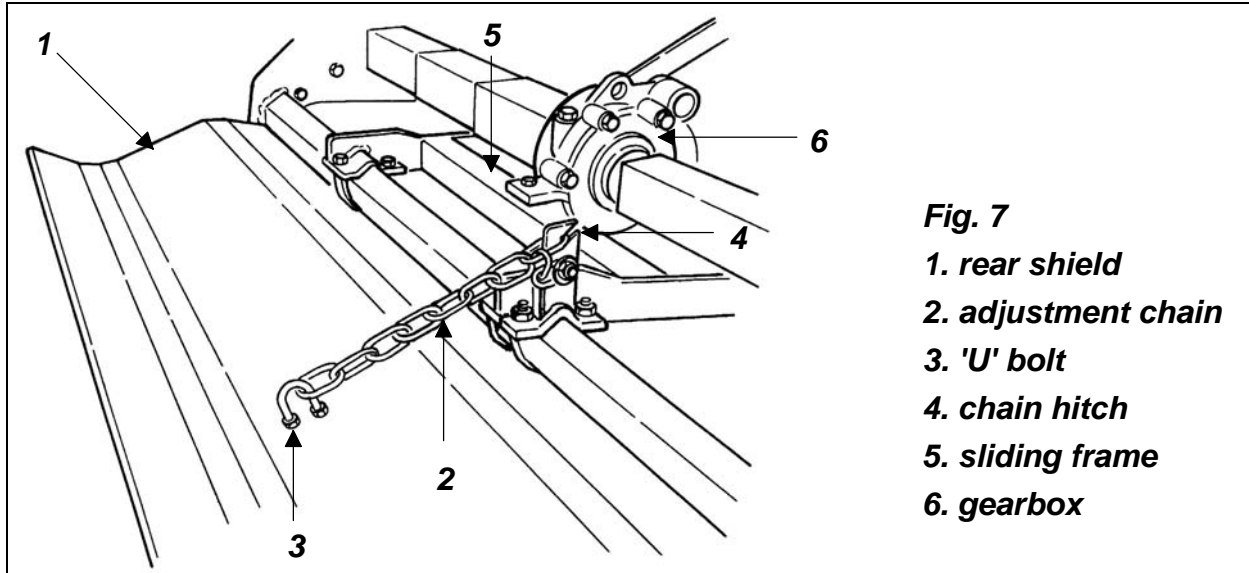
**Fig. 7**

- 1. rear shield
- 2. adjustment chain
- 3. 'U' bolt
- 4. chain hitch
- 5. sliding frame
- 6. gearbox

3.03 - Side-Shift

The side-shift capability gives the tiller numerous advantages over center mounted tillers. It can till next to shrubs, sidewalks or buildings. Smaller sizes can cover wider tractor tire tracks.

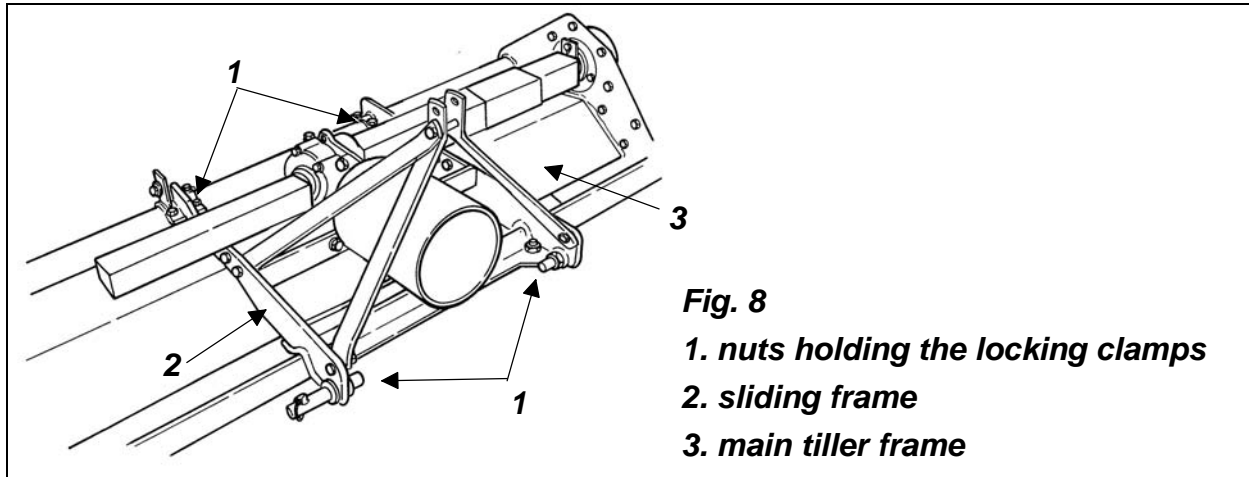
**Fig. 8**

- 1. nuts holding the locking clamps
- 2. sliding frame
- 3. main tiller frame

To side-shift the tiller from the center mount position, do the following:

1. Loosen the 8 nuts (#1, fig. 8) holding the locking clamps to the front and rear of the gearbox housing. Do not remove the nuts.
2. Push the sliding frame (#2, fig. 8) towards the left to its new desired position. This can be done without levers or turnbuckles. Do not shift it right of center.
3. Re-tighten the 8 nuts.

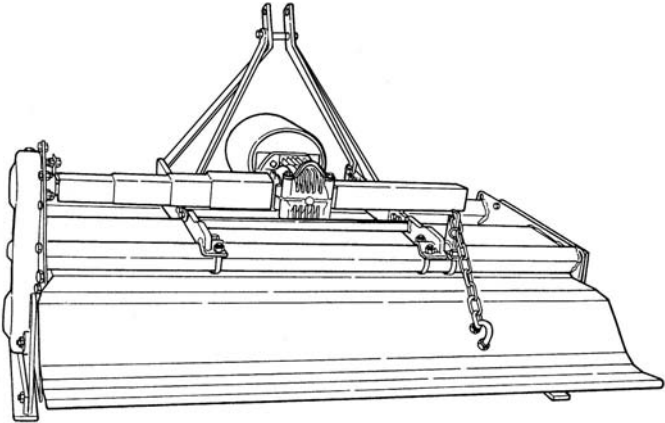
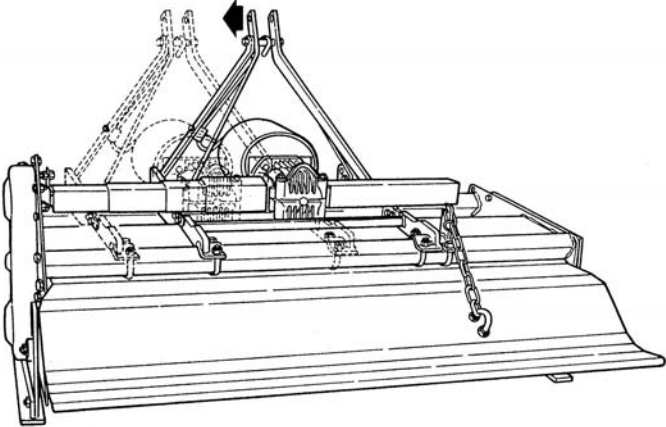
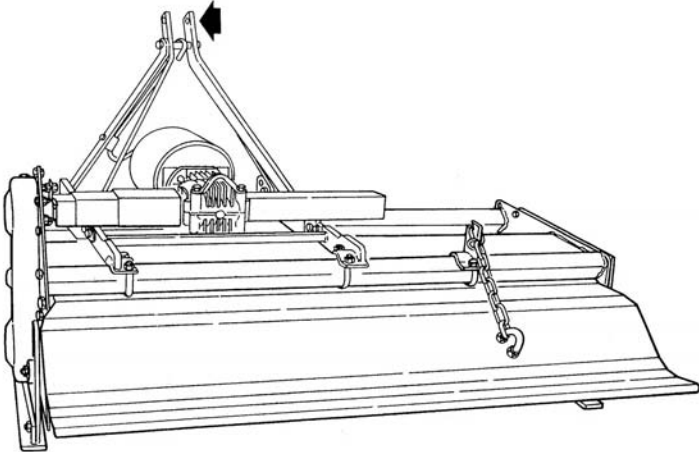

Fig. 9
The three point linkage can be shifted from the center mount position (a) to the left (b) into the desired position (c).

(a)



(b)



(c)

TABLE 1

The drawing below represents the Till-Rite T50 tiller's right side-shift capabilities. The upper black line of the drawing shows the three point hitch of the tiller working in its center position. The lower white line shows the three point hitch of the tiller shifted completely to the right.

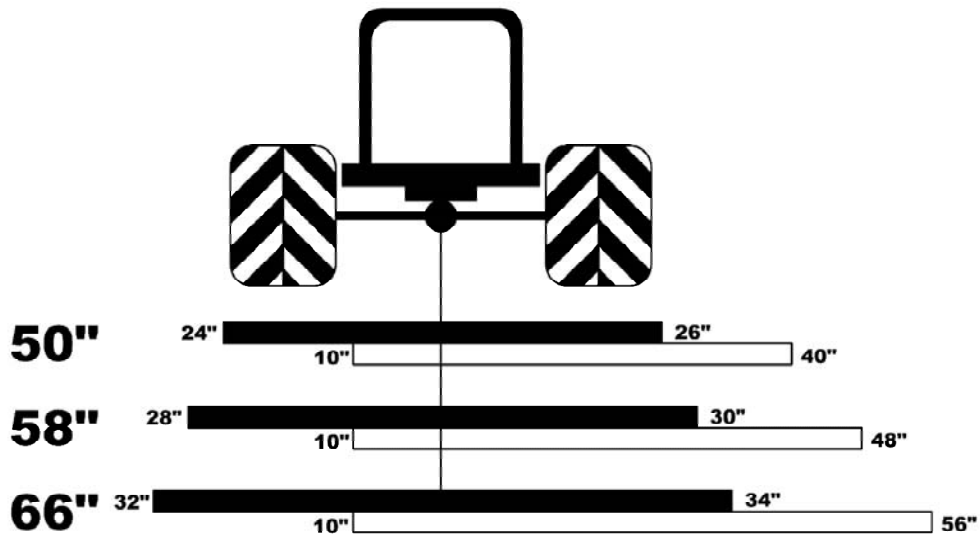

3.04 - Depth Control

The tilling depth is controlled by raising or lowering the side skids. The tilling depth is at its maximum when the skids are touching the side plates. Lowering the skids, raises the tiller from the ground and lowers its working depth.

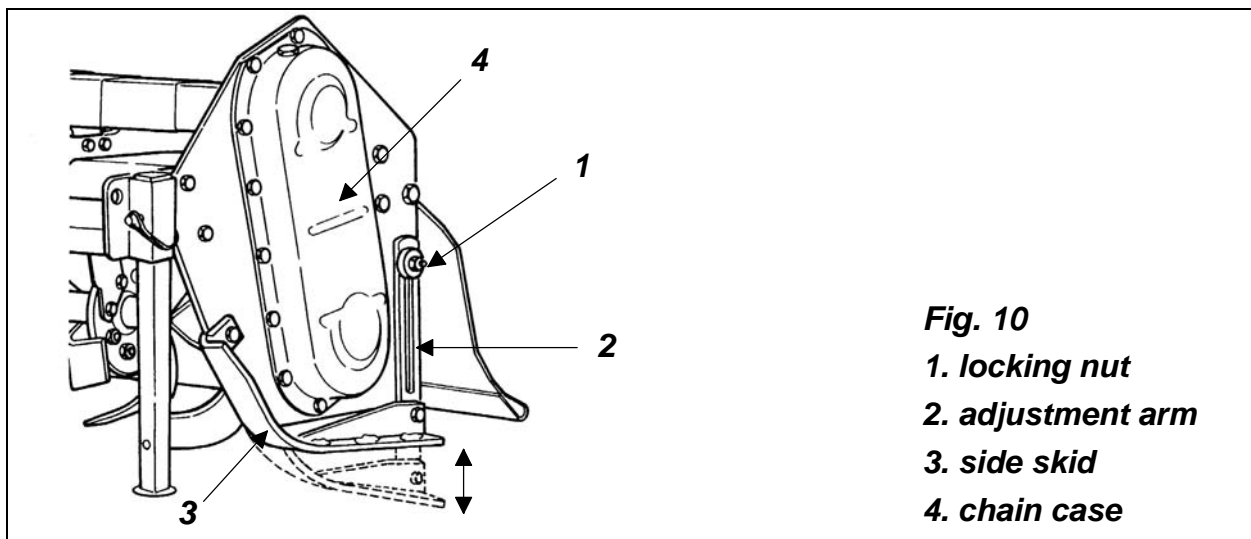

To raise or lower the side skids proceed as follows:

1. Loosen the nut (**see #1, fig. 10**) on the adjustment arm (**see #2, fig. 10**).
2. Place the skid (**see #3, fig. 10**) in the desired position.
3. Re-tighten the nut (**#1**) on the adjustment arm (**#2**).
4. Repeat this operation on the other skid, ensuring both skids are level.

3.05 - Rear Shield Adjustments

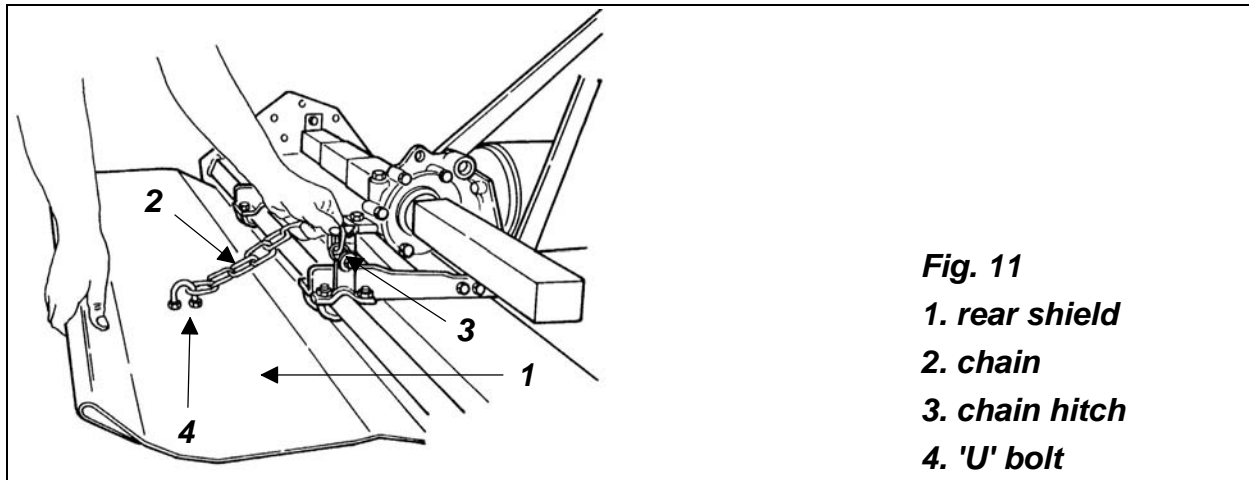

Fig. 11

- 1. rear shield**
- 2. chain**
- 3. chain hitch**
- 4. 'U' bolt**

The rear shield, for safety reasons, must always remain in contact with the ground. This also ensures better pulverization of the soil and helps level it out.

Raise rear shield (**see #1, fig. 11**) to the desired position. Hook the chain (**see #2, fig. 11**) to the chain hitch (**see #3, fig. 11**).

3.06 - Pre-Operational Check

Check each of the following carefully prior to engaging the equipment:

1. The rotor bearing has been greased and the drive chain is lubricated.
2. The oil level in gearbox. Using a flashlight, check inside the gearbox to verify that it's approximately half full.
3. The driveline cross and bearings have been greased.
4. No wrappings or foreign objects are on the machine or driveline.
5. The blades are properly installed and the blade bolts and nuts properly torqued⁷.
6. All hardware is tight.
7. The tractor to ensure correct direction of rotation of PTO and rpm speed.
8. All safety shields and guards are in place and tightly attached.
9. No people or animals are in the work area.
10. Local utility companies have been contacted to make certain there are no bundled gas lines, electrical cables, etc., in the work area.
11. When working, make sure the tractor hitch is in the "float" position, in order to allow the tiller to rest on the skids and therefore to follow the contour of the ground.

⁷ See Table 2, page 31.



CAUTION: Engage the tractor PTO only when the tiller blades are 1.5" to 2" from the ground.



WARNING: Stay clear of rotating driveline. Entanglement in rotating driveline can cause serious injury or death. Disengage PTO, engage parking brake or place transmission in "Park", shut off the tractor and remove the key before working around hitch, attaching or detaching driveline, making adjustments, servicing or cleaning the machine.

3.07 - Attaching to the Tractor

Unit may be used on tractors ranging from 25 to 50 HP⁸ equipped with a standard rear PTO and category 1 three point hitch or a cat. 1 quick hitch⁹.



CAUTION: Check the tractor PTO rpm to ensure it is set at 540 and turns clockwise. Always ensure that the tractor tire pressure is correct according to the tractor operator's manual.

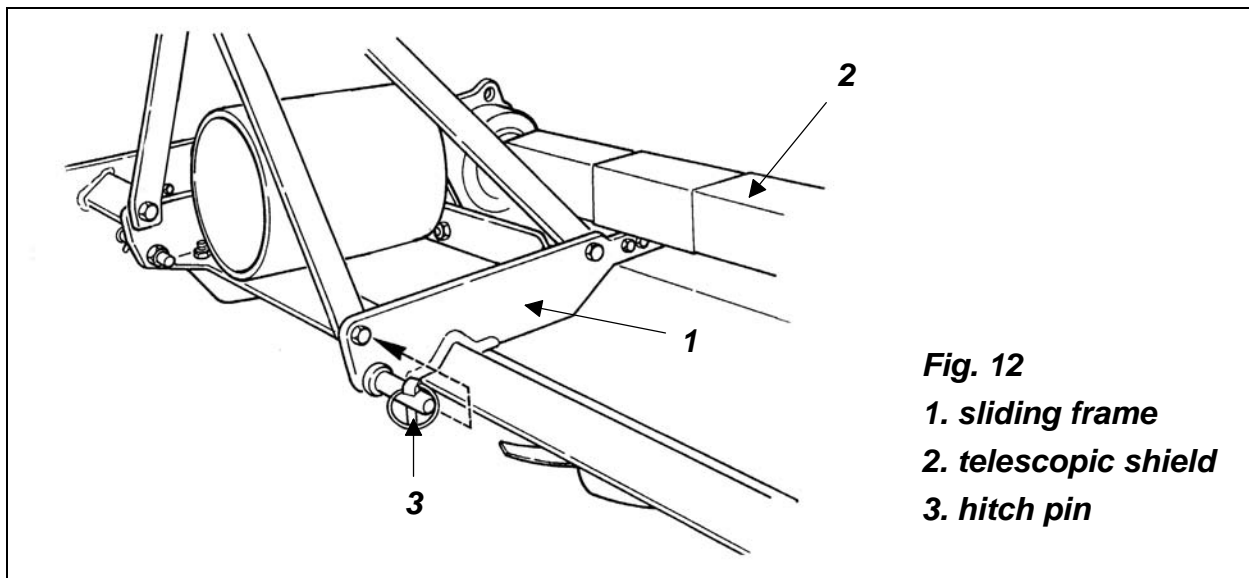

Fig. 12
 1. sliding frame
 2. telescopic shield
 3. hitch pin

⁸ See Table 3, page 31.

⁹ Units are quick hitch compatible starting from serial #353886.



WARNING: Disengage PTO, wait for all movement from the implement and tractor to stop, engage parking brake or place transmission in "Park", shut off the tractor and remove the key before attaching the implement to the tractor.

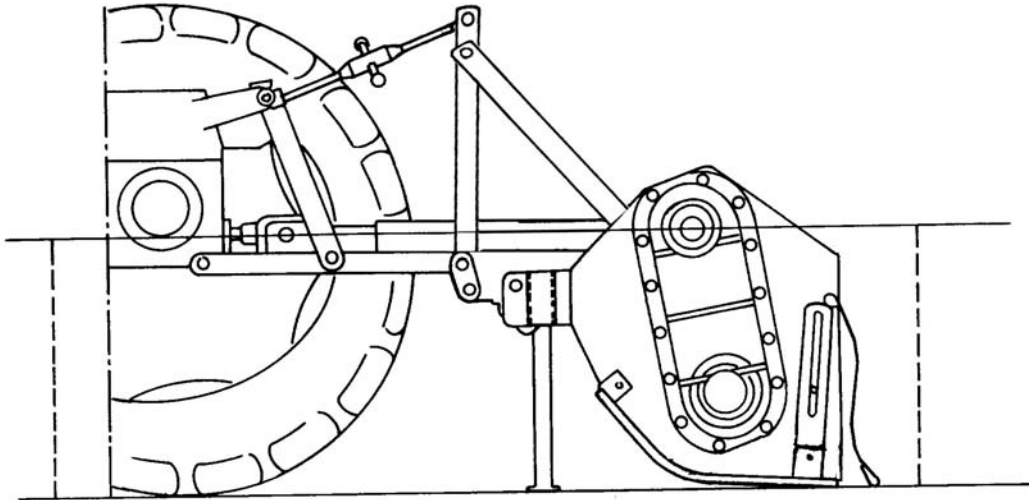

Fig. 13 - Correct work position of the tiller. A 1 to 2 degree rearward tilt is acceptable.

To attach the tiller to the tractor do the following:

1. Back the tractor up to the machine in order to slip the tractor hitch arms over the hitch pins attached to the sliding frame. **Turn off the tractor engine.**
2. The tiller hitch pin (**#3, fig. 12**) may be positioned in either the top or bottom hole, depending on driveline length and tractor size.
3. Lock the tractor arms to the tiller hitch arms with the lynch pins. Stabilizers must be used to limit side swing to 2" to 3".
4. Attach the top link. Adjust it so the tiller is as near parallel to the ground as possible. A 1 to 2 degree rearward tilt is acceptable (**see fig. 13**).
5. Install the shielded driveline to the tractor by first lining up the splines and depressing the snap pin. Push the yoke onto the PTO shaft as far as it will go. Release the pin and pull back slowly until the pin clicks in place.
6. Repeat this operation on the implement end if the tiller is **supplied with a shear bolt**.
7. If the implement is **supplied with a slip clutch**, first remove the sheet metal protection on the gearbox, remove the locking bolt on the slip clutch yoke and push the yoke on to the gearbox shaft. Line the locking bolt hole up with the groove on the shaft. Reinstall the locking bolt and tighten down lock nut. Reinstall PTO protective cover.
8. Attach the safety chains of the PTO shaft to the tiller and the tractor to keep the shielding from rotating. Allow enough slack for the sliding plastic shielding to slide in and out.

IMPORTANT: See Section 4.04 - Driveline, to ensure the driveline is the proper length.



DANGER: Tractor-implement combinations can create unstable unions with a chance of roll-over. If necessary, front weights need to be added to the tractor in order to maintain balance. Always ensure that the tractor tire pressure is correct according to the tractor operator's manual.

3.08 - Start Up



DANGER: Never allow anyone around the tiller when it is in operation. Engage the tractor PTO only when the tiller blades are 1.5" to 2" from the ground.



DANGER: Operate the implement only at the speed and direction of rotation indicated on the machine. Serious damage can result if this is not followed.



CAUTION: Before starting work, clear the area of any obstacles or foreign objects.

Begin tilling at the lowest ground speed possible, increasing until the desired speed is reached. Engage the PTO with the tiller just clear of the ground. Open the throttle to $\frac{3}{4}$ of its full power speed and lower the tiller into the ground. Open up the throttle to full power. **Avoid working in reverse.**

Before beginning work always remember that the operator is responsible for:

1. Safe and correct operation of the tractor and tiller.
2. Learning and following precise, safe operating procedures for both the tractor and the tiller.
3. Ensuring all maintenance and lubrication has been performed on the tiller.
4. Having read and understood all safety aspects for the tiller in the operator's manual.
5. Having read and understood all safety decals on the tiller.
6. Checking the condition of the blades. Worn or damaged blades should be changed before starting.
7. Checking to ensure that the cutting edge is the leading edge of the blade.
8. Checking that there are no wires, weeds, grass or other objects wrapped around the rotor.

9. Checking to see if front weights need to be added to the tractor in order to maintain balance.
10. Checking the tractor tires for the proper pressure in accordance to the tractor operator's manual.
11. Checking that all shields are on the machine and securely in place.
12. Making sure proper attire is worn. Avoiding loose fitting clothing which can become entangled. Wearing sturdy, tough-soled work shoes and protective equipment for eyes, hands, ears and head. Never operate tractor or implements in bare feet, sandals or sneakers.
13. Checking area for stones, branches and other debris that might be thrown.
14. Ensuring proper lighting is available, sunlight or good artificial lighting.



DANGER: Never operate without all shields on the machine and securely in place. The tiller blades can throw objects which could result in personal or property damage. Enter new areas carefully.



CAUTION: For emergency reasons, learn how to stop the tractor and implement quickly. Always disengage the PTO, lock parking brake, stop engine and allow the blades to come to a complete stop before dismounting the tractor.



WARNING: Do not allow the tractor rpm to go below full throttle when working. This can cause damage to your tractor.

3.09 - Test Run

After running the tiller 120 to 150 feet, raise the machine and just as the blades lift up from the soil, disengage the PTO, lower the tiller and shut off the tractor engine. Assure that the machine is properly adjusted and functioning properly. After the first five minutes of operation, stop and feel the gearbox. It should be warm to the touch but not hot.

3.10 - Working Depth

Tilling depth is determined largely by the condition of the ground. When working on hard or on previously unworked ground, set maximum depth at 2" to 3". Greater depth may require a second pass.

NOTE: Excessive vibration or jumping of the machine is an indication that the machine is working too deep for conditions, such as in hard, parched or compacted soil and should be adjusted accordingly.

3.11 - Working Speed

Ground speed is determined by the soil condition, tilling depth and tractor power. Simple experimentation will soon determine the best speed for the desired results, usually 1 to 2 mph.

3.12 - Finer Pulverization

A slow ground speed will result in a finer soil, as a faster ground speed will render the opposite. The rear shield, besides being a safety device, will help in producing a finer worked soil. Test results show that a raised shield will leave a coarser finished surface.

3.13 - Headland Procedure

When the headland is reached, it is important that the following be observed:

1. Raise the machine from the ground and as soon as the blades leave the ground, disengage the tractor PTO.
2. Turn the tractor facing the new desired direction of travel.
3. Begin working again¹⁰.

NOTE: Best practice dictates that the machine be lifted no more than just enough to clear the ground. Running the machine at an angle above 15° could damage the PTO.

3.14 - Working Limitations

If the tiller does not penetrate the ground easily, conditions may be too dry, tough or compacted. This condition is evidenced by vibration and jumping of the machine. Also check that the blades are properly installed with the proper scroll (**see fig. 15**).

The combination of excessively hard ground and rocky conditions will greatly reduce the life of the blades. Under these extreme conditions it may be wise not to use the tiller as the primary tillage tool and therefore it is advised to run over the ground with a disc or plow prior to tilling.

3.15 - Uneven Terrain



DANGER: Be careful when operating tractor and machine over uneven ground to avoid roll-over.

¹⁰ See Section 3.06 - Pre-Operational Check.

The following precautions should always be observed when working on uneven terrain:

1. In extremely uneven terrain rear wheel weights, front tractor weights, and/or tire ballast should be used to improve stability.
2. Observe the type of terrain and develop a safe working pattern.
3. Whenever traction or stability is doubtful, first test drive over the terrain with the PTO disengaged.
4. Operate the implement up and down steep slopes, not across slopes, to prevent the tractor from tipping. Avoid sudden stops and starts, slow down before changing directions on a slope.
5. Pass diagonally through sharp dips and avoid sharp drops to prevent hanging up the tractor and implement.
6. Slow down on sharp turns and slopes to prevent tipping or loss of control.
7. Watch for holes, roots or other hidden objects. Do not use near the edge of a gully, ditch or stream bank.

3.16 - Transport

During transport or when the machine is lifted from the ground, it is advisable to adjust the tractor lift arms in order to be able to raise the machine 14" to 16" from the ground (see fig. 14).



CAUTION: All transport operations are to be done without the tiller working, and respecting all local traffic rules and regulations.

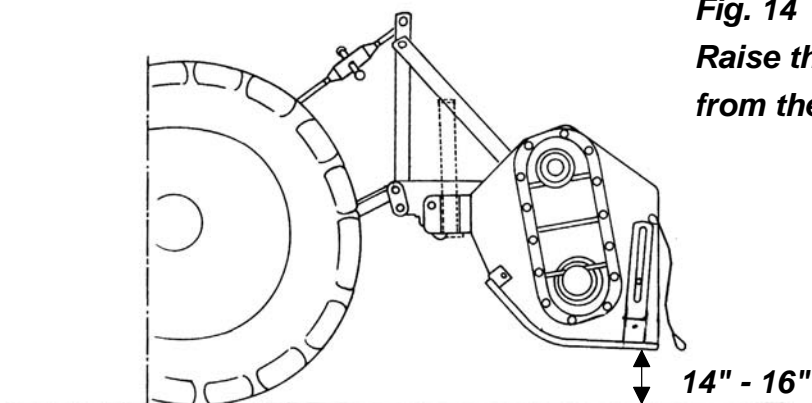

Fig. 14
Raise the machine 14" to 16"
from the ground during transport.

4 - MAINTENANCE



DANGER: Stop engine, lock parking brake and remove key before performing any service or maintenance.

Never rely on the tractor lift system. Install blocks or stands under the machine to prevent it from falling. Always use personal protection devices, such as glasses or gloves when performing maintenance.

Keep fingers out of slots to prevent injury.

4.01 - Maintenance Safety



1. Good maintenance is your responsibility.
2. Keep service area clean and dry. Be sure electrical outlets and tools are properly grounded. Use adequate light for the job at hand.
3. Make sure there is plenty of ventilation. Never operate the engine of the towing vehicle in a closed building. The exhaust fumes may cause asphyxiation.
4. Make no repair or adjustments with the tractor engine running. Before working on the machine, disengage the PTO, shut off the engine, set the brakes, and remove the ignition key.
5. Be certain all moving parts on attachment have come to a complete stop before attempting to perform maintenance.
6. Never work under equipment unless it is blocked securely.
7. Always use personal protection devices such as eye, hand and hearing protectors, when performing any service or maintenance.
8. Frequently check blades. They should be sharp, free of nicks and cracks and securely fastened.
9. Periodically tighten all bolts, nuts and screws and check that all cotter pins are properly installed to ensure unit is in a safe condition.
10. When completing a maintenance or service function, make sure all safety shields and devices are installed before placing unit in service.
11. After servicing, be sure all tools, parts and service equipment are removed.
12. Never replace hex bolts with less than grade five bolts unless otherwise specified, i.e. shear bolts¹¹.
13. Where replacement parts are necessary for periodic maintenance and servicing, genuine replacement parts must be used to restore your equipment to original specifications. The company will not claim responsibility for use of unapproved parts and/or accessories and other damages as a result of their use.

¹¹ Refer to Table 2 - Torque Specifications, for head identification marking, page 31.

14. Unauthorized modifications to the machine may impair the function and/or safety of the machine and reduce its life. If equipment has been altered in any way from original design, the manufacturer does not accept any liability for injury or warranty.

4.02 - Lubrication

The accompanying illustrations show lubrication points. The chart gives the frequency of lubrication in hours, based on normal operating conditions. Severe or unusual conditions may require more frequent lubrication.

Use a good quality SAE multipurpose type grease for all locations shown. Be sure to clean fittings thoroughly before using grease gun.

Use 90 wt. gear oil in gearbox.

1. **Hourly:** Remove any wrapping (stalks, weeds, trash, etc.) from tiller, especially from around bearing supports on the rotor ends.
2. **Every four hours:** Ensure bolts holding the side shift are tight.
3. **Daily:** Ensure blades are not broken and bolts are tight. Grease the rotor support, the driveline cross and bearings and telescopic tubes. Check gearbox oil level by removing the breather plug. Using a flashlight, check inside the gearbox to verify that it's approximately half full. When filled correctly the oil level should be approximately halfway on the input shaft. When fully drained gearbox requires approximately 24 fl. oz. (0.7 qt.) of oil. If needed add SAE 90W gear oil.

Note: Never overfill gearbox. Oil will expand when hot. Overfilling will likely cause excess oil to blow out of breather cap.

4. **Weekly:** Check the blades for excessive wear or damage. Ensure the rotor turns freely. Inspect the chain in the chain case and make sure it is well lubricated.
5. **After the first 200 hours:** Remove the chain case cover (being sure not to damage the gasket), clean the chain sprockets with kerosene, replace the sprockets and reassemble using fresh GP grease (approximately 2.2 lbs).

4.03 - Blade Maintenance



WARNING: To avoid possible injury, wear proper eye and hand protection when servicing tiller blades.

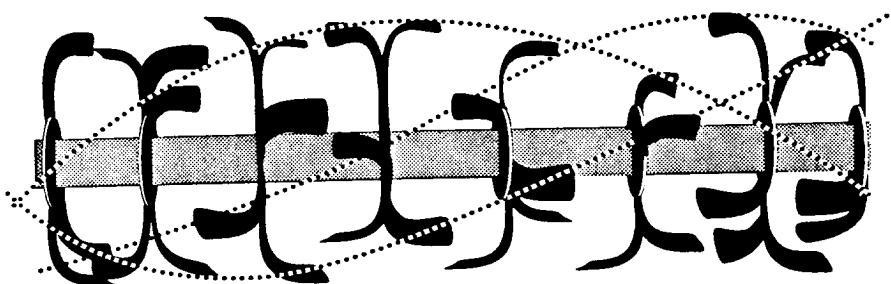

Fig. 15

It is important to change blades after **they have worn down 1" to 1¼"** from their original length. When replacing blades, it is best to replace them one at a time to maintain the original scroll pattern. If, however, it becomes necessary to remove them all, **it is essential to maintain the scroll pattern of the blades (see fig. 15)**. To do this, remove one blade and immediately replace it with a new one. Be sure the bolt head (**see #3, fig. 16**) is touching the blade (**#4**), while the washer (**#5**) and nut (**#6**) contact the flange. Sometimes a locknut is used instead of a lock washer and nut. Proceed until all blades needed to be changed are changed.

After installing the new blades, tighten the nuts to their proper torque specifications.

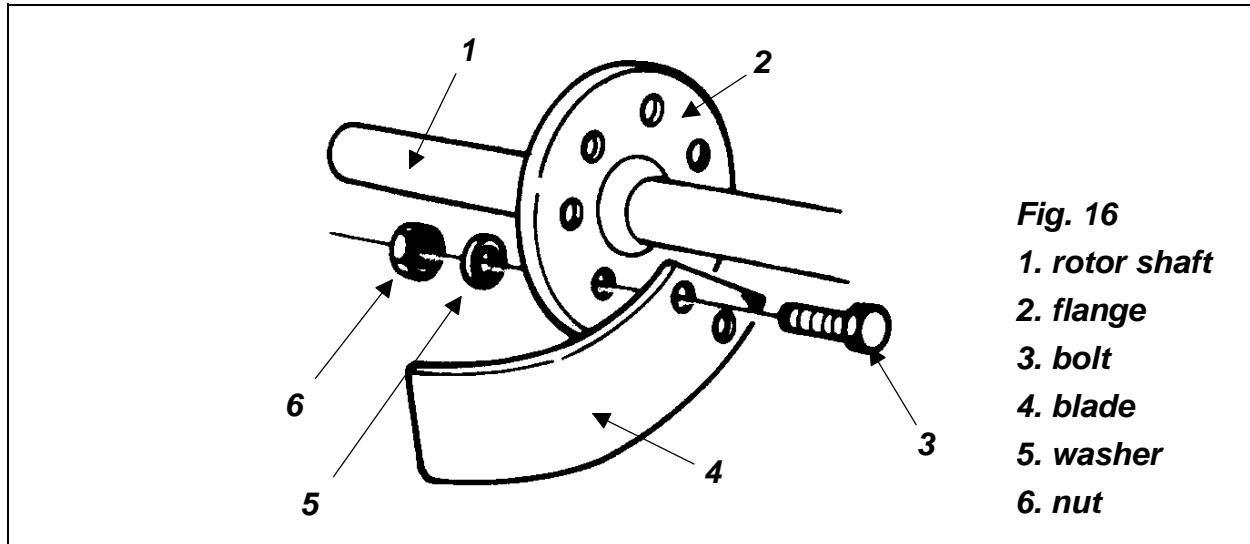

Fig. 16
 1. rotor shaft
 2. flange
 3. bolt
 4. blade
 5. washer
 6. nut

To determine if a blade is right or left, do the following:

1. Hold the blade in the palm of the hand with the bend pointing upward and away from you.
2. If the cutting edge points towards the right then the blade is right-handed.
3. The cutting edge pointing to the left indicates a left-handed blade.

4.04 - Driveline



DANGER: Only use the original driveline supplied with this tiller and always with the safety shielding in place.

Carefully read and file away the driveline operator's manual supplied by the manufacturer. The following does not substitute the information found in the driveline manual.

IMPORTANT: Always check driveline length during initial setup and when connecting to a different tractor.

In the collapsed position the driveline should be approximately 2" from bottoming out to prevent possible damage to the tractor or implement. When the driveline is in the maximum possible extended position, the ideal minimum overlap of the two halves should be approximately 6" (see fig. 17).

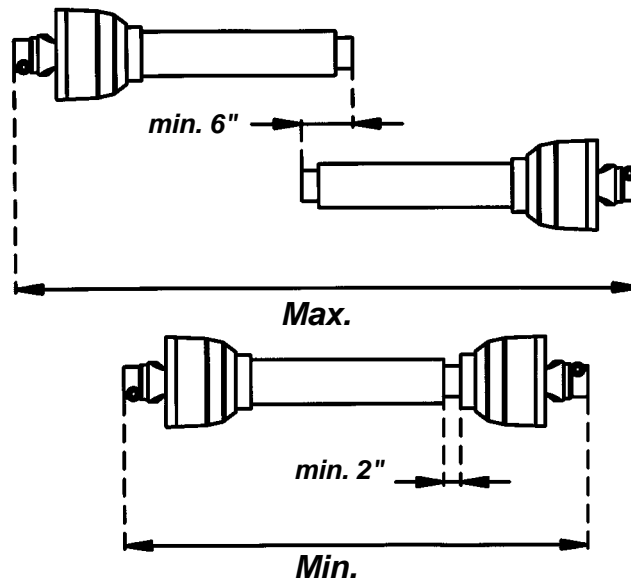

Fig. 17

If determined that the driveline is too long, follow these procedures to adjust the length:

1. Separate the two driveline halves. Connect one half to the tractor PTO and the other half to the tiller.
2. Raise and lower the machine with the 3 point hitch to find the position where the driveline is shortest. Hold the half shafts side by side and mark the desired length on the outer female guard tube leaving a 2" gap between the end of the guard tube and bell guard.
3. Cut off both guard tubes the same amount as marked in step 2.
4. Shorten both drive tubes the same amount as guard tubes.
5. De-burr and clean filings from drive tubes and apply grease to outside of inner telescoping tube.
6. Reassemble the driveline halves and connect to tractor and tiller. Raise and lower tiller again to be sure driveline does not bottom out in shortest position and has a minimum overlap of 6" in the longest position.
7. Install both driveline safety chains. One should be hooked in a hole on the outer driveline yoke shield and to the tractor to restrict outer shield rotation. The second one should be hooked in a hole on the inner driveline yoke shield and to the implement to restrict inner shield rotation.

If determined that the driveline is too short for your tractor, contact your local dealer.



CAUTION: Always work with the driveline as straight as possible. This will prolong its life and that of its components. It is advised not to work at an angle greater than 15 degrees.

4.05 - Safety Shear Bolt



CAUTION: When this machine is equipped with a shear bolt driveline, for the protection of the PTO and gearbox, never replace the shear bolt with anything harder than a class 8.8 bolt. All warranties will be void if a bolt harder than a class 8.8 is used.

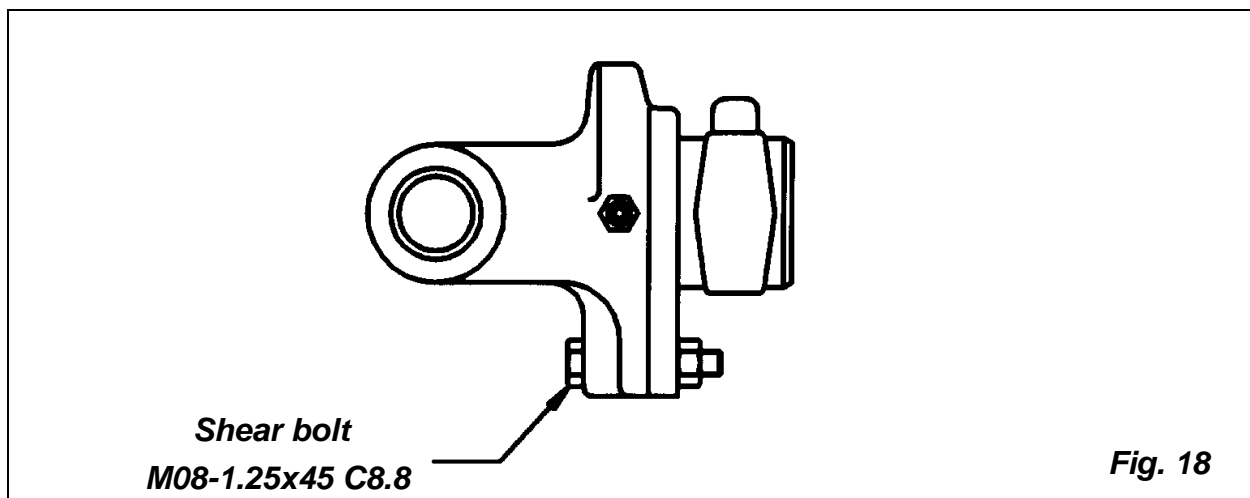

In the case of a shear bolt breaking (the operator will notice that the tiller will stop even though the tractor PTO is still engaged), disengage the PTO, stop and turn off the tractor. **Replace the broken shear bolt M08-1.25x45 class 8.8 with another having the identical characteristic of the original (see fig. 18).**

Substituting different shear bolts other than those indicated by the manufacturer can render the safety inoperable.

4.06 - Safety Slip Clutch

When the tiller is supplied with a safety slip clutch, it is important to ensure it is working properly. The slip clutch delivered with your machine is set at a specific torque for normal working conditions.

If the clutch slips frequently while the unit is working, it may be necessary to tighten the spring nuts (**see fig. 19**) on the slip clutch. Tighten the spring nuts in ½ turn increments, then test run the unit for 600 to 800 ft. Repeat the operation if necessary. The discs on

the clutch need to be replaced in the event that the clutch continues to slip even though the spring nuts have been tightened.
Follow the instructions in reverse, if while working under normal conditions the clutch does not slip at all.

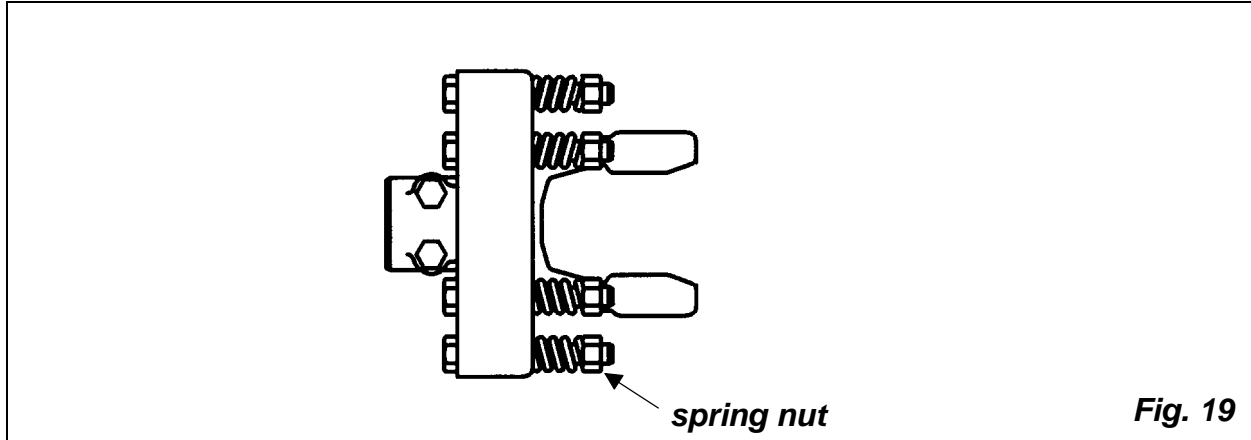







Fig. 19

TABLE 2 - TORQUE SPECIFICATIONS

Metric (ISO) treaded bolts head marking							Inch (SAE) treaded bolts head marking								
	Class 5.8		Class 8.8		Class 10.9			Grade 2		Grade 5		Grade 8			
Bolt size mm	Thread mm	N.m	ft-lb	N.m	ft-lb	N.m	ft-lb	Bolt size inch	Thread inch tpi	N.m	ft-lb	N.m	ft-lb	N.m	ft-lb
M5	0.8	4	3	6	4	9	7	1/4"	20	7	5	11	8	16	12
M6	1	6	4	10	7	15	11	1/4"	28	8	6	13	10	19	14
M8	1.25	16	12	25	18	36	27	5/16"	18	15	11	24	17	33	25
M8	1	17	13	26	19	38	28	5/16"	24	17	13	26	19	37	27
M10	1.5	31	23	48	35	71	52	3/8"	16	27	20	42	31	59	44
M10	1.25	33	24	51	38	75	55	3/8"	24	31	23	47	35	67	49
M10	1	35	26	53	39	78	58	7/16"	14	43	32	67	49	95	70
M12	1.75	54	40	84	62	123	91	7/16"	20	48	36	75	55	106	78
M12	1.5	56	41	87	64	128	94	1/2"	13	66	48	102	75	144	106
M12	1.25	59	44	90	66	133	98	1/2"	20	75	55	115	85	163	120
M14	2	84	62	133	98	195	144	9/16"	12	95	70	147	109	208	154
M14	1.5	94	69	142	105	209	154	9/16"	18	106	79	164	121	232	171
M16	2	131	97	206	152	302	223	5/8"	11	132	97	203	150	287	212
M16	1.5	141	104	218	161	320	236	5/8"	18	149	110	230	170	325	240
M18	2.5	181	133	295	218	421	310	3/4"	10	233	172	361	266	509	376
M18	2	196	145	311	229	443	327	3/4"	16	261	192	403	297	569	420
M18	1.5	203	150	327	241	465	343	7/8"	9	226	167	582	430	822	606
M20	2.5	256	189	415	306	592	437	7/8"	14	249	184	642	473	906	668
M20	1.5	288	212	454	335	646	476	1"	8	339	250	873	644	1232	909
M22	2.5	344	254	567	418	807	595	1"	12	371	273	955	704	1348	995
M22	1.5	381	281	613	452	873	644	1-1/8"	7	480	354	1077	794	1746	1288
M24	3	444	327	714	526	1017	750	1-1/8"	12	539	397	1208	891	1958	1445
M24	2	488	360	769	567	1095	808	1-1/4"	7	677	500	1519	1120	2463	1817
M27	3	656	484	1050	774	1496	1103	1-1/4"	12	750	553	1682	1241	2728	2012
M27	2	719	530	1119	825	1594	1176	1-3/8"	6	888	655	1992	1469	3230	2382
M30	3.5	906	668	1420	1047	2033	1499	1-3/8"	12	1011	746	2268	1673	3677	2712
M30	2	1000	738	1600	1180	2250	1659	1-1/2"	6	1179	869	2643	1949	4286	3161
M36	4	1534	1131	2482	1830	3535	2607	1-1/2"	12	1326	978	2974	2194	4823	3557

When using lock washers with nuts, increase torque values by 5%.

TABLE 3 - ROTARY TILLERS - TECHNICAL FEATURES

Series T50 for tractors up to 50 HP, PTO 540, cat. 1 three point hitch - Chain: ASA 100											
Model	HP	Working width	Overall width	Weight lb.	Side-shift	# of flanges	# of blades	Rotor rpm	Chain sprockets	Working depth	Driveline 1 ³ / ₈ "
T50-250	25-50	50"	55"	462	40"	6	24	226	10-13	8.4"	ASAE cat. 4 slip clutch
T50-258	30-50	58"	63"	506	48"	7	28	226	10-13	8.4"	
T50-266	35-50	66"	72"	550	56"	8	32	226	10-13	8.4"	
T50-350	25-50	50"	55"	481	40"	6	36	226	10-13	8.4"	ASAE cat. 4 slip clutch
T50-358	30-50	58"	63"	528	48"	7	42	226	10-13	8.4"	
T50-366	35-50	66"	72"	575	56"	8	48	226	10-13	8.4"	

5 - REPAIR PROCEDURES



CAUTION: All repair procedures must be done by authorized dealerships. It is not recommended that untrained individuals perform any repair work. The following operations are detailed for qualified personnel only.

5.01 - Gearbox

To remove the gearbox from the side-shift frame proceed as follows:

1. Remove the rear bolt holding the gearbox to the side-shift frame.
2. Slide the side-shift frame over until the gearbox is off the hexagonal shaft.
3. Unbolt the bolts holding the front plate to the side-shift frame.
4. Whenever the bearings are removed from the gearbox, all oil seals should be replaced to assure no leaks when the box is reassembled.
5. To avoid damage to components, bearings should always be removed with bearing pullers and pressed in when being replaced.
6. When reassembling the gearbox, ensure that there is precise mesh between ring and pinion gears.
7. Fill gearbox with approximately 24 fl. oz. of SAE 90W gear oil.

5.02 - Chain Case

To remove the chain do the following:

1. Unbolt chain case cover.
2. Remove the chain case cover taking care not to damage the gasket.
3. Release the automatic chain tensioner spring.
4. Remove the two snap rings holding the chain sprockets.
5. Slip off both chain sprockets at the same time.

To replace the chain follow the procedure in reverse order, ensuring the gasket is not damaged. If damaged it must be changed.

5.03 - Rotor

Removing the rotor is a simple operation. The complete rotor consists of a center rotor made of heavy piping with blade flanges welded to it in a scrolled pattern and two side support flanges (one right and one left). The center rotor is attached to the two side support flanges with special bolts. To remove the center rotor, simply remove these bolts and slip the center rotor out from the two support flanges.

5.04 - Suggested Spare Parts

It is suggested that the following spare parts be kept on hand at all times to prevent a minor problem from delaying work:

Description	Quantity
Right hand blade	6
Left hand blade	6
Blade bolt	12
Blade nut and washer	12
Shear bolt complete	12
Chain	1

5.05 - Storage

After seasonal use it is important to perform the following for prolonged storage:

1. Wash the tiller carefully.
2. Inspect the tiller and replace worn or damaged parts.
3. Tighten all hardware.
4. Grease all areas indicated under Maintenance¹².
5. Touch up scratches by sanding the area and applying a light coat of primer and paint to prevent rust from forming.
6. Cover the tiller from the elements in order to have it in perfect condition for the start of the next season.
7. Store driveline in dry area. A slip clutch can become inoperative if the discs stick together. Be sure to check the clutch before using the tiller after prolonged storage.
8. Make sure all parked machines are on a hard, level surface, and engage all safety devices.
9. Do not permit children to play on or around the stored unit.

Touch up paint available:	
Part #	Description
7300007	Primer, gray - aerosol spray can
7300008	Paint, Befco orange - aerosol spray can
7300010	Paint, Befco black - aerosol spray can



WARNING: Be sure to store the implement on a hard level surface and away from people especially children.

The machine demolition operations should be carried out in compliance with all federal, state and local environment protection laws.

¹² See Chapter 4 - Maintenance.

6 - TROUBLESHOOTING



WARNING: Be sure tractor engine is off, parking brake is locked, and key is removed before making any adjustments.

PROBLEM	POSSIBLE CAUSE	SOLUTION
Machine makes intermitting clicking noise.	Loose blade bolts. Gearbox gears or chain damaged.	Tighten blade bolts. Replace damaged gears or chain.
PTO vibrates.	Worn cross and bearings. Driveline working at too great of an angle. Wrappings around rotor shaft.	Replace worn cross and bearings. Reduce the working angle of the driveline. Check for wrappings on rotor shaft.
Gearbox noise is noticeable and constant.	Oil level low. Worn Gears.	This can be normal on a new machine until it has been run in. Check oil level. Replace worn gears.
Blades stop turning but PTO, gearbox and hexshaft are turning.	Broken drive chain.	Remove chain case and check for broken connector link.
PTO turning but not blades.	Broken shear bolt.	Check shear bolt. If sheared, replace it.
Machine skips and leaves crop residue.	Worn blades. Slip clutch slipping. Ground speed too fast.	Check for badly worn blades. If worn down to tip, overlap will be lost and cutting will deteriorate. Replace worn blades. Check slip clutch. Reduce ground speed.
Machine smells hot or begins to smoke.	Wrappings around rotor. Slip clutch slipping. Gearbox oil low.	Can be caused by friction from trash heavily wrapped around bearing protection covers. Remove trash immediately, damage to bearing could result. Check slip clutch. Check oil level in gearbox and lubricant on chain.
Oil leak from gearbox.	Oil seal or grease fitting damaged. Gearbox overfilled.	Replace oil seal or grease fitting. Remove excess oil.

7 - PRE-DELIVERY CHECKLIST

To the dealer: Inspect the machine thoroughly after assembly to assure it is functioning properly before delivering it to the customer. The following checklist is a reminder of points to cover. Check off each item as it is found satisfactory or after proper adjustment is made.

- Gearbox oil level.
- Guards and shield properly fastened.
- Lubrication of grease fittings.
- All hardware properly tightened.
- All decals properly located and readable (**see fig. 2**).
- Overall condition (touch up scratches, clean and polish).
- Test run, check for excessive vibrations or overheating of bearings.
- Operator's Manual.

Review the Operator's Manual with the customer. Explain the following:

- Warranty.
- Safe operation and service.
- Correct machine installation and operation.
- Daily and periodic lubrication, maintenance and inspections.
- Troubleshooting
- Operational procedures and storage.
- Parts and service.
- Remove and fill out the Pre-Delivery Checklist and Warranty Registration form.
- Give customer the Operator's Manual and encourage the customer to read the manual carefully.

IMPORTANT: Warranty is not valid unless Pre-Delivery Checklist and Warranty Registration form in Operator's Manual is completed in detail and mailed to the Company.

Model Number: _____ Serial Number: _____

Delivery Date: _____ Dealer's Signature: _____

8 - WARRANTY

BEFCO's responsibility will be limited to substitution of the acknowledged defective merchandise to the same place of delivery as the previous one was supplied.

1. LIMITED WARRANTY

BEFCO, Inc. herein referred to as the Company, warrants its machines and related accessories, hereafter referred to as the Machine, to be free from defects in material and workmanship, for a period of twelve (12) months from the date of invoice to the first registered owner; this limited warranty does not apply to common wear items and excludes belts, shear pins, oil, grease, tires, tubes, hydraulic hoses, knives and PTO shafts.

Labor will be reimbursed at \$40.00 per hour based on BEFCO's time schedule.

Cost of transport to the servicing dealer is the responsibility of the customer.

Warranty coverage shall not be transferable from the first owner to any subsequent owner.

2. DISCLAIMER OF ALL OTHER WARRANTIES AND REMEDIES

Neither the Company nor any company affiliated with the Company makes any warranties, representations or promises, expressed or implied, as to the quality, performance or application of its products other than those set forth herein and does not make any implied warranty of merchantability or fitness.

The only remedies the purchaser has in connection with the breach, or performance of any warranty on the Company's Machine are those set forth herein. In no event will the dealer, the Company, or any company affiliated with the Company, be liable for:

- a. Injuries or damages of any kind or nature, direct, consequential or contingent to person or property.
- b. Any expenses incurred by the owner to repair, replace or rework any allegedly defective item.
- c. Any loss, cost, forfeiture or damages (including loss of profits; loss of crops; loss because of delay in field operations; any expenses or loss incurred for labor, supplies, substitute machine rental; liabilities of the owner to its customers or third persons; and all other consequential damages, losses, liabilities or damages for any other reasons) whether direct or indirect, and whether or not resulting from or contributed to by the default or negligence of the Company, its agents, employees and subcontractors which might be claimed as a result of the use or failure of the equipment delivered.

The Company's liability based on this limited warranty or any other applicable laws shall be limited to replacement or refund of the purchase price of the product.

The limited warranty extended herein gives you specific rights and you may also have other rights which vary from state to state. Neither the dealer nor the Company personnel has the authority to make any representation or to modify the terms and limitations of this warranty in any way.

Other than the limited warranty extended hereby there is no other expressed warranty in connection with the design, safety or use of any of the Company's products except as to title. All implied warranties are expressly disclaimed pursuant to the terms of this warranty.

3. CUSTOM WORK

If the Machine is used for commercial purposes such as custom work, the period warranted for the Machine is limited to six (6) months from the date of delivery to the first registered owner and does not cover any labor charges incurred.

4. RENTAL

If the Machine is used for rental purposes the period warranted for the Machine is limited to thirty (30) days from the date of delivery to the first registered owner and does not cover any labor charges incurred.

5. REGISTRATION

In order to qualify for coverage on this limited warranty, the product and name of the original purchaser must be registered with the Company by a completed Machine Pre-Delivery Checklist and Warranty Registration along with a copy of the dealer's invoice to the first registered owner to the Company within fourteen (14) days after the date of delivery to the original purchaser.

6. WARRANTY SERVICE

Warranty Service must be performed by a dealer authorized by BEFCO. If the warranty service requested is approved, the owner shall pay only for labor beyond the rate allowed, for overtime labor, and for any mileage charge for transporting the equipment to and from the dealer's shop. It is assumed that the dealer has the appropriate general and special tools to service the Machine. Time required for replacement of knives, oil, grease and to remove excessive dirt from the Machine is not subject to reimbursement by the Company. The owner is required to clean the Machine before presenting it to the dealer for service work. The Machine must be delivered within thirty (30) days after failure date by the owner to the dealer to be eligible for warranty consideration.

7. UNAPPROVED SERVICE OR MODIFICATION

All obligations of the Company under this limited warranty shall be terminated if:

- a. Proper service and operation instructions as outlined in the Operator's Manual and on the instruction sticker on the Machine, are not followed.
- b. The Machine is modified or altered in any way not approved by the Company.
- c. The Company does not receive a copy of the dealers invoice to the first registered owner within fourteen (14) days from the date of delivery.
- d. The Company has not been paid in full, by the dealer, for the Machine.

8. ACCIDENTS AND NORMAL MAINTENANCE

This limited warranty covers defective material and workmanship. It does not cover depreciation or damage caused by normal wear, accidents, improper maintenance, improper protection or improper use. The costs of normal maintenance or repairs for accidents or improper use, and related labor will be borne by the owner.

9. REPLACEMENT PARTS

BEFCO, Inc. warrants replacement parts to be free from defect in material and workmanship for a period of thirty (30) days from the date of delivery to the original purchaser.

WARRANTY REGISTRATION

BEFCO, Inc.
P.O. Box 6036
Rocky Mount, NC 27802-6036

Tel: (252) 977.9920 - Fax: (252) 977.9718

Dealer _____ Acct. # _____	Retail Customer _____
Street _____ Country _____	Street _____
Town _____ State _____ Zip _____	Town _____ State _____ Zip _____
Date of delivery _____ Invoice # _____	Phone _____
Model # _____ Serial # _____	
<p>Pre-Delivery Checklist:</p> <p><input type="checkbox"/> Oil in gearbox.</p> <p><input type="checkbox"/> Greased fittings.</p> <p><input type="checkbox"/> Safety guards in place.</p> <p><input type="checkbox"/> All hardware tight.</p> <p><input type="checkbox"/> Bolts torqued correctly.</p> <p><input type="checkbox"/> Attached unit to tractor. Yes/No.</p> <p><input type="checkbox"/> Field adjusted. Yes/No.</p> <p><input type="checkbox"/> Test run. Dry/Infield.</p> <p><input type="checkbox"/> Safety decals.</p> <p><input type="checkbox"/> Operator's Manual.</p> <p>The machine described above, had been prepared for delivery according to the Pre-Delivery Checklist and the Customer has been instructed in its care and operation and the condition of warranty.</p>	<p>Tractor make: _____</p> <p>Model: _____; HP _____</p> <p>Type of operation: Private homeowner, Landscaping, Commercial maintenance, Golf Course, Municipality, Turf Farm, others: _____</p> <p>Approximate number of acres machine will be used on annually: _____</p> <p>I hereby acknowledge that: I have received and accepted delivery of the machine described. The equipment was checked thoroughly for loose or missing parts and has been adjusted in accordance with the Pre-Delivery Checklist. I have read and understand the nature and extent of the warranty and understand clearly that there were and are no other representations of warranties either expressed or implied, made by anyone. I have been advised on proper operation, maintenance and lubrication procedure of this equipment. I have been instructed on and do understand the application, limitation and capacities this equipment was designed and recommended for, all as described in the Operator's Manual and literature published by the Company.</p>
Inspected by: _____	
Date: _____	Date: _____
Dealer's Signature: _____	Customer's Signature: _____

This registration along with a copy of the invoice must be sent to BEFCO, Inc. within 14 days of date of purchase.

Fold here

*Place stamp
here*

BEFCO, Inc.

Warranty Department

P.O. Box 6036

Rocky Mount, NC 27802-6036

Cut along this line



BEFCO®

Parts Manual

TILL-RITE

Side-Shift Rotary Tiller

T50-250, 350

T50-258, 358

T50-266, 366

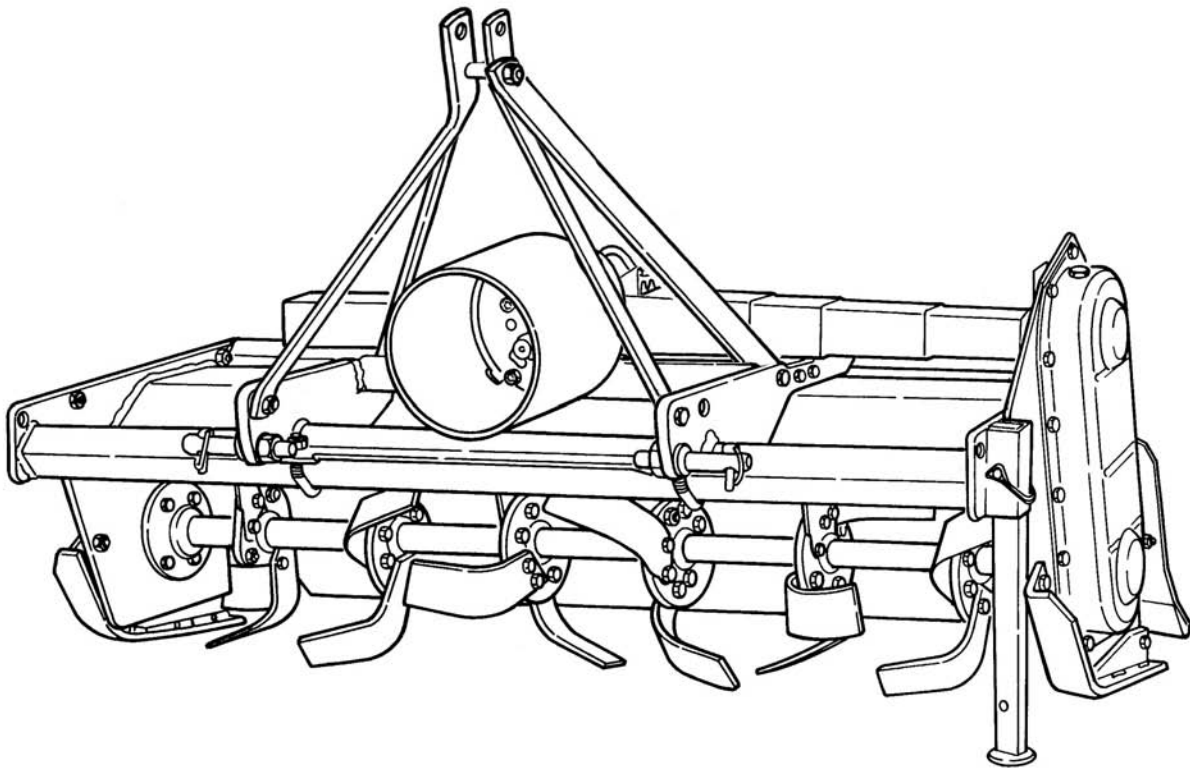

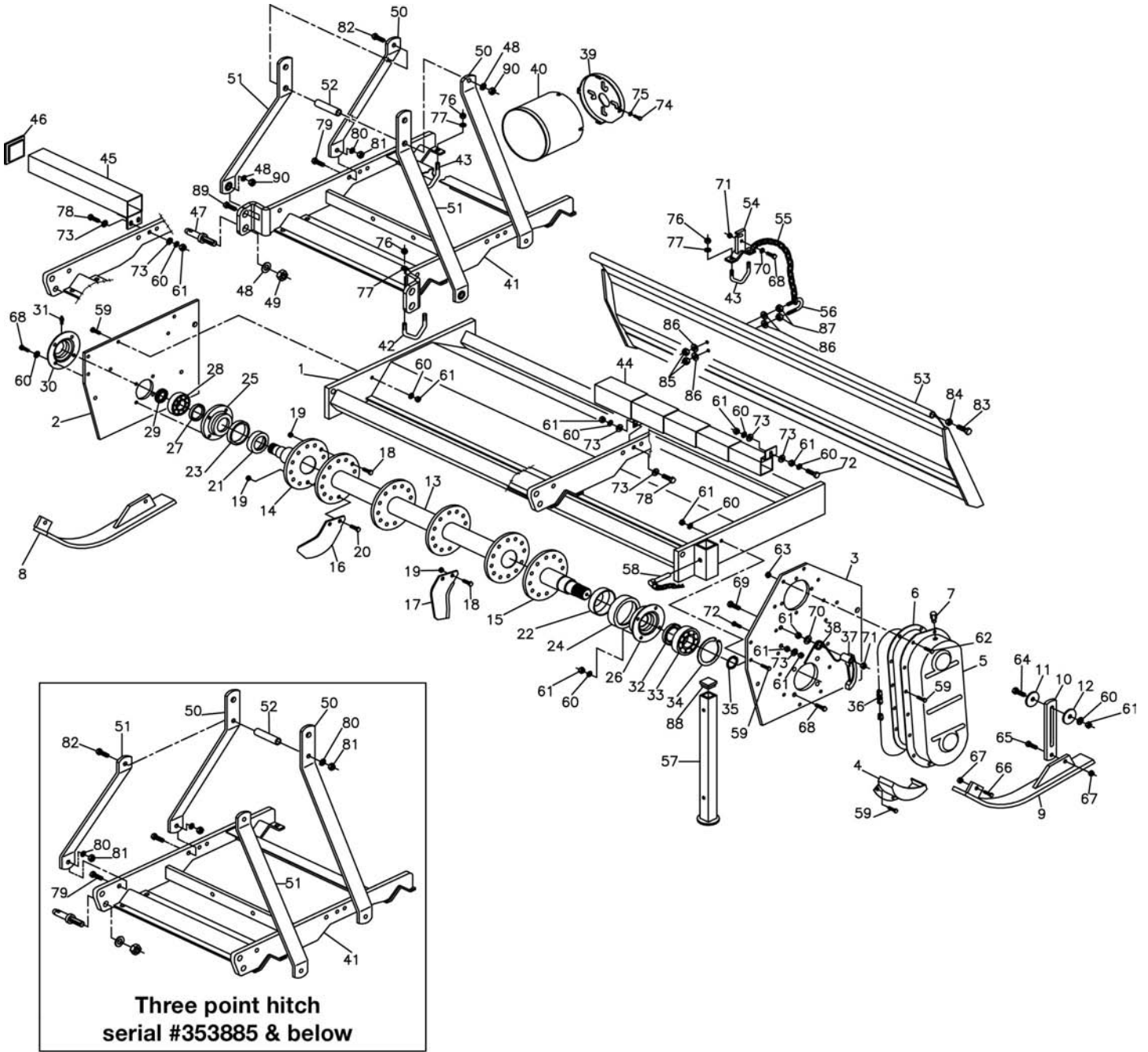

Ref.	Part #	Description	Qty.
1	038-6002	Frame 50"; T50-X50	1
	048-6002	Frame 58"; T50-X58	1
	058-6002	Frame 66"; T50-X66	1
2	008-6011	Right side panel	1
3	008-6021	Drive panel	1
4	003-0667	Chain case cover protection	1
5	003-5030	Chain case cover	1
6	003-0666	Gasket	1
7	000-1107A	Breather cap	1
8	018-6041	Skid, right	1
9	028-6041	Skid, left	1
10	002-1051	Serrated adjustment arm	2
11	002-1052	Washer threaded M10-1.50 Z	2
12	002-1053	Washer with hole Ø10 Z	2
13	033-0081	Rotor 50"; T50-250 Ver. A & below ¹³	1
	038-6361	Rotor 50"; T50-250 Ver. B, T50-350	1
	043-0081	Rotor 58"; T50-258 Ver. A & below ¹⁴	1
	048-6361	Rotor 58"; T50-258 Ver. B, T50-358	1
	053-0081	Rotor 66"; T50-266 Ver. A & below ¹⁵	1
	058-6361	Rotor 66"; T50-266 Ver. B, T50-366	1
14	008-6365	Flanged pivot, right; T50-2XX Ver. B, T50-3XX	1
15	008-6370	Flanged pivot, left; T50-2XX Ver. B, T50-3XX	1
16	000-1071D	Tine "C" style, right; T50-2XX Ver. A & below ¹⁶	-
	003-0104D	Tine "C" style, right; T50-2XX Ver. B, T50-3XX	-
17	000-1071S	Tine "C" style, left; T50-2XX Ver. A & below ¹⁷	-
	003-0104S	Tine "C" style, left; T50-2XX Ver. B, T50-3XX	-
18	000-1073	Bolt SP M12-1.25x35 C8.8 P	-
19	002-1105	Nut PT M12-1.25 C6 Z	-
20	007-7055	Bolt SP M12-1.25x45 C12.9 Z P	-
21	002-2074	Dirt shield (requires welding)	1
22	003-0084	Dirt shield, left (requires welding)	1
23	008-4083	Dirt shield (requires welding)	1
24	003-0123	Dirt shield (requires welding)	1
25	003-0092	Inner cover; T50-2XX Ver. A & below	1
	001-0073	Cover; T50-2XX Ver. A & below	1
	008-4081	Right support, complete; T50-2XX Ver. B, T50-3XX	1
26	003-0121	Rotor support, left	1
27	003-4098	Oil seal 40.60.10; T50-2XX Ver. A & below	1
	005-7567	Oil seal 40.56.8; T50-2XX Ver. B, T50-3XX	1
28	003-0094	Bearing 6306	1
29	003-0095	Locking ring ES GUK M30-1.50	1

¹³ Rotor #038-6361 can be ordered instead, provided that the following items are also replaced: Left (#008-6370) and right (#008-6365) flanged pivots; complete right support (#008-4081); left (#003-0104S) and right (#003-0104D) blades and oil seal (#005-7567).

¹⁴ Rotor #048-6361 can be ordered instead, provided that the following items are also replaced: Left (#008-6370) and right (#008-6365) flanged pivots; complete right support (#008-4081); left (#003-0104S) and right (#003-0104D) blades and oil seal (#005-7567).

¹⁵ Rotor #058-6361 can be ordered instead, provided that the following items are also replaced: Left (#008-6370) and right (#008-6365) flanged pivots; complete right support (#008-4081); left (#003-0104S) and right (#003-0104D) blades and oil seal (#005-7567).

¹⁶ Blades must be purchased in pairs (right & left blade).

¹⁷ Blades must be purchased in pairs (right & left blade).

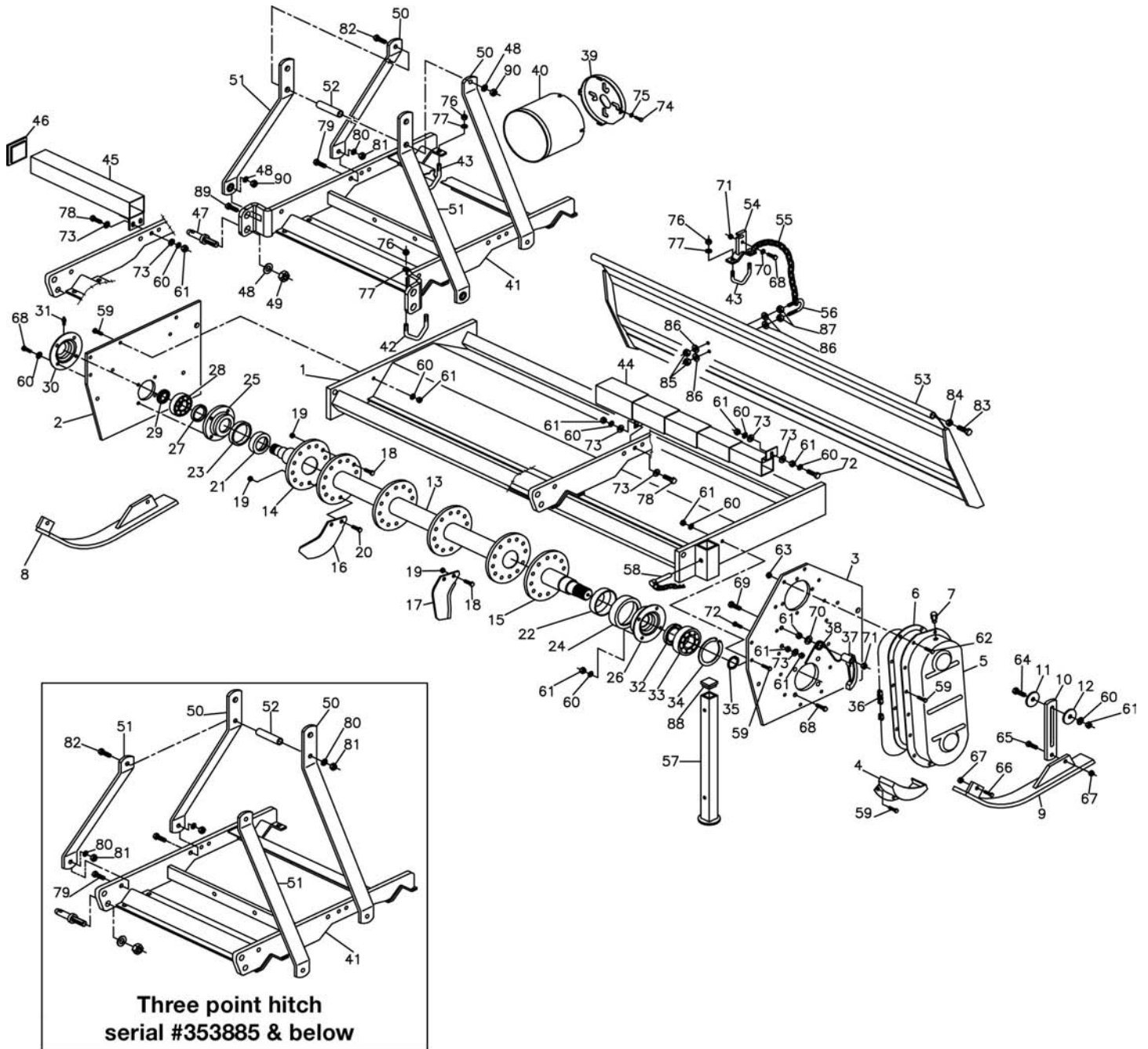

Ref.	Part #	Description	Qty.
30	003-0091	Outer cover, right	1
31	000-1065	Grease fitting M10-1.00 threaded	1
32	000-3306	Oil seal 45.80.10	1
33	000-1148	Bearing 6308	1
34	000-8137	Snap ring, inner Ø90	1
35	000-8138	Snap ring, outer Ø40	1
36	003-0146	Chain ASA 100x32	1
37	003-0148	Chain tensioner	1
38	003-0158	Spring, chain tensioner	1
	001-1130	Spring, chain tensioner, for reverse rotation (option)	1
39	001-1201	Guard support	1
40	001-1207	Guard, PTO shaft	1
41	008-6241	Side shift complete; #353885 & below	1
	008-6211	Side shift complete; #353886 & above	1
42	001-1251	Bolt "V" M12-1.75x67x73 Z	2
43	001-1253	Bolt "V" M12-1.75x54x65 Z	3
44	028-6260	Telescopic shielding 50"-58"; T50-250, 258, T50-350, 358 #313776 & below	1
	028-6265	Telescopic shielding 50"-58"; T50-350, 358 #313777 & above	1
	038-6260	Telescopic shielding 66"; T50-266, T50-366 #313776 & below	1
	038-6265	Telescopic shielding 66"; T50-266, T50-366 #313777 & above	1
45	021-1265	Right protection 50"; T50-X50	1
	031-1265	Right protection 58"; T50-X58	1
	041-1265	Right protection 66"; T50-X66	1
46	005-8330	Plastic cap	1
47	000-5550	Hitch pin	2
48	000-5351	Washer lock Ø20 Z	2
49	000-5542	Nut HH M20-1.50 C6 Z MD	2
50	008-6282	Arm, top hitch; #353885 & below	2
	008-6284	Arm, top hitch; #353886 & above	2
51	008-6283	Support, top hitch; #353885 & below	2
	008-6285	Support, top hitch; #353886 & above	2
52	002-1285	Spacer; #353885 & below	1
	001-6116	Spacer; #353886 & above	1
53	038-6399	Tail gate 50"; T50-X50 ¹⁸	1
	048-6399	Tail gate 58"; T50-X58 ¹⁹	1
	058-6399	Tail gate 66"; T50-X66 ²⁰	1
54	001-1311	Chain hitch	1
55	001-0318	Chain	1
56	001-1327	Bolt "U" M08-1.25x21x51 Z	1
57	001-1332	Stand	1
58	001-1333	Lynch pin Ø10x70	1
59	003-3176	Bolt HH M10-1.50x25 C8.8 Z F	15
60	000-1280	Washer lock Ø10 Z	27
61	000-1279	Nut HH M10-1.50 C6 Z TK	26
62	000-6349	Bolt HH M10-1.50x20 C8.8 Z F	10
63	009-0150	Nut HH M10-1.50 C6 Z MD	14

¹⁸ Replaces part #033-0303.¹⁹ Replaces part #043-0303.²⁰ Replaces part #053-0303.

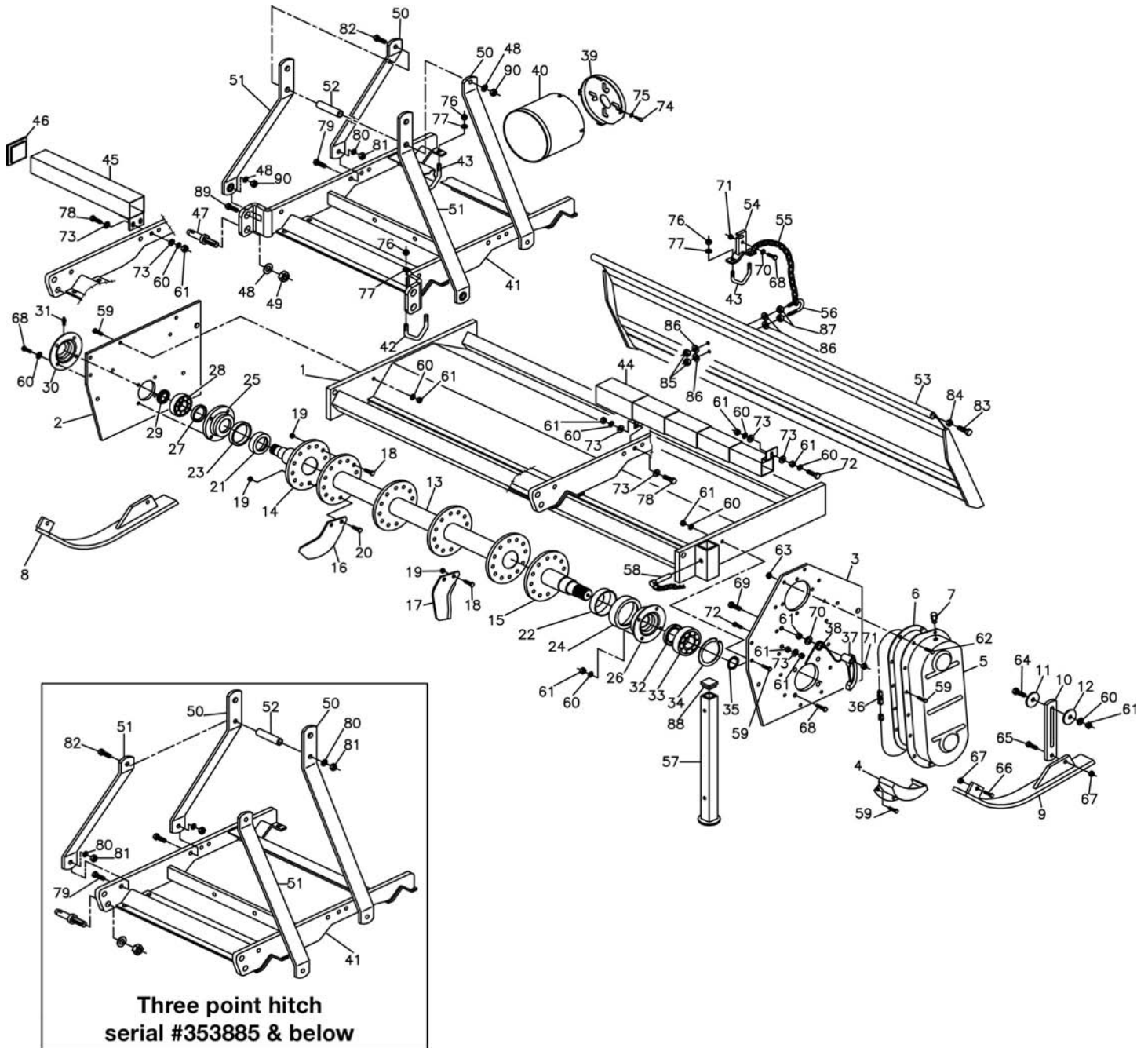

Ref.	Part #	Description	Qty.
64	003-0331	Bolt HH M10-1.50x50 C8.8 Z F	2
65	000-7255	Bolt HH M12-1.75x35 C8.8 Z F	2
66	001-5255	Bolt HH M12-1.75x30 C8.8 Z F	2
67	003-0064	Nut PT M12-1.75 C6 Z TK	4
68	000-1278	Bolt HH M10-1.50x30 C8.8 Z F	11
69	003-0640	Bolt HH M10-1.50x65 C8.8 Z F	1
70	003-0157	Washer fender Ø10 Z	4
71	003-0156	Nut PT M10-1.50 C6 Z TK	4
72	002-6329	Bolt HH M10-1.50x45 C8.8 Z F	2
73	000-2034	Washer flat Ø10 Z	11
74	001-1210	Bolt PN M06-1.00x12 C4.6 Z F	4
75	001-1209	Washer fender Ø06 Z	4
76	000-3038	Nut HH M12-1.75 C6 Z TK	10
77	000-1077	Washer lock Ø12 Z	10
78	003-8614	Bolt HH M10-1.50x40 C8.8 Z F	4
79	002-9317	Bolt HH M14-2.00x50 C8.8 Z F	2
80	000-1020	Washer lock Ø14 Z	2
81	000-1019	Nut HH M14-2.00 C6 Z TK	2
82	003-7368	Bolt HH M14-2.00x120 C8.8 Z P; #353885 & below	1
	000-9843	Bolt HH M20-2.50x130 C8.8 Z P; #353886 & above	1
83	003-0309	Bolt HH M16-2.00x70 C8.8 Z F	2
84	000-3124	Nut HH M16-2.00 C6 Z MD	2
85	001-1328	Nut PT M08-1.25 C6 Z TK	2
86	001-5230	Washer flat Ø08 Z	4
87	004-6545	Nut HH M08-1.25 C6 Z MD	2
88	001-1336	Plastic cap 30 mm.	1
89	000-5540	Bolt HH M20-2.50x55 C8.8 Z F; #353886 & above	2
90	000-5350	Nut HH M20-2.50 C6 Z TK; #353886 & above	3

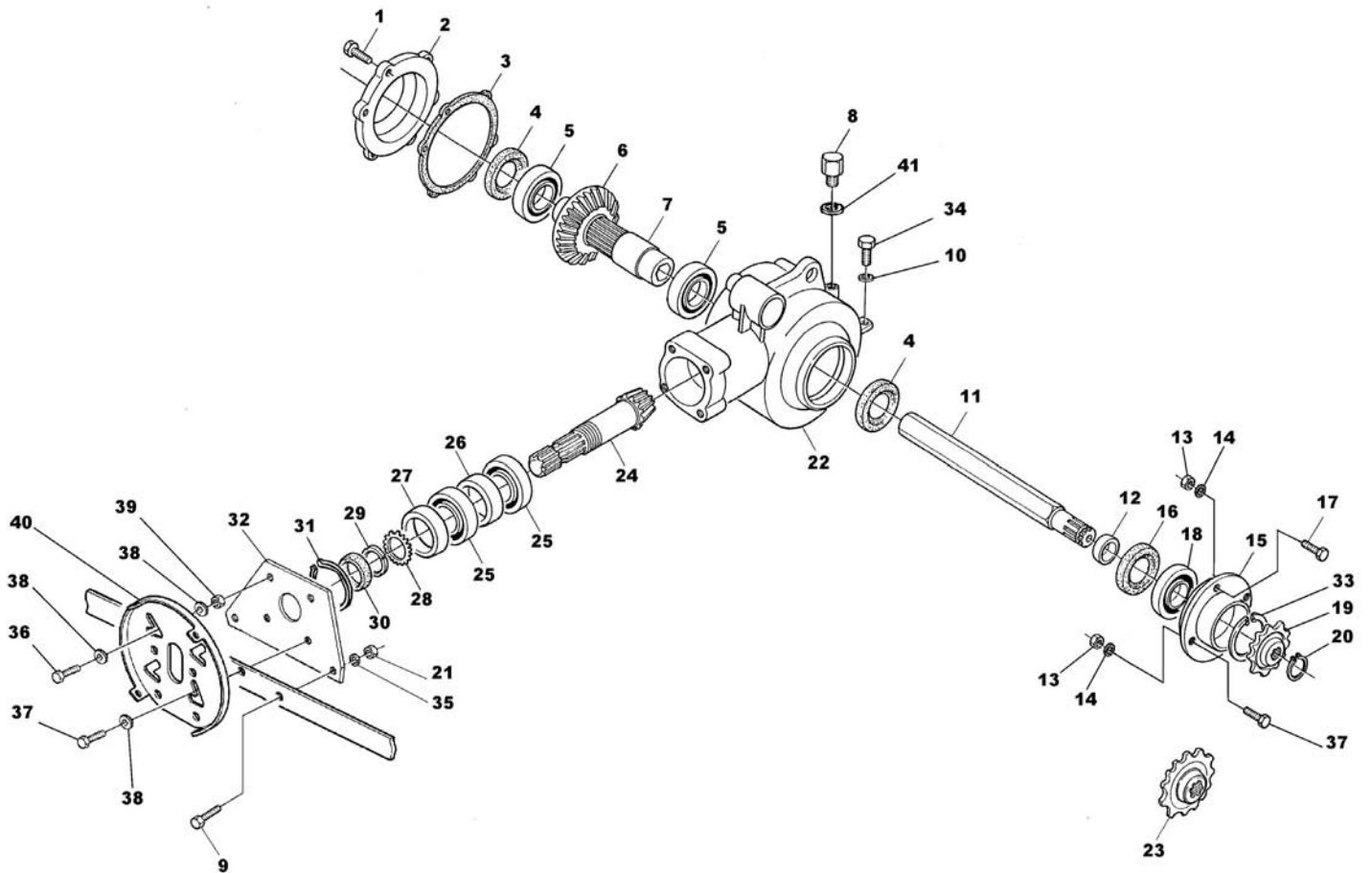

Ref.	Part #	Description	Qty.
1	000-6349	Bolt HH M10-1.50x20 C8.8 Z F	6
2	003-0191	Gear cover	1
3	003-0193	Gasket 2/10	-
	013-0193	Gasket 5/10	-
4	000-1084	Oil seal 55.72.10	2
5	003-0188	Bearing 6011	2
6	003-0196	Ring gear	1
7	003-0190	Shaft coupling; T50-2XX, T50-3XX #313776 & below	1
	008-6164	Shaft coupling; T50-3XX #313777 & above	1
8	000-1107A	Breather cap	1
9	000-1043	Bolt HH M12-1.75x35 C8.8 N F	2
10	000-1020	Washer lock Ø14 Z	1
11	033-0180	Hexagonal shaft 50"; T50-X50	1
	043-0180	Hexagonal shaft 58"; T50-X58	1
	053-0180	Hexagonal shaft 66"; T50-X66	1
12	001-3044	Spacer	1
13	000-1279	Nut HH M10-1.50 C6 TK Z	4
14	000-1280	Washer lock Ø10 Z	4
15	003-0162	Flange, top shaft	1
16	000-1155	Oil seal 50.80.10	1
17	002-6329	Bolt HH M10-1.50x45 C8.8 Z F	1
18	000-1148	Bearing 6308	1
19	003-0143	Sprocket Z10	1
20	000-8138	Snap ring, outer Ø40	1
21	000-3038	Nut HH M12-1.75 C6 Z TK	2
22	003-0184A	Housing, gearbox; T50-2XX, T50-3XX #313776 & below	1
	008-6163	Housing, gearbox; T50-3XX #313777 & above	1
23	000-1113	Sprocket Z13	1
24	003-0197	Pinion gear	1
25	003-0201A	Bearing 30208	2
26	003-0203	Spacer, rear	1
27	003-0695	Spacer, front	1
28	000-7827	Washer lock MB Ø8 Z	1
29	000-7826	Locking ring KM 8 M40-1.50	1
30	003-0680	Oil seal 35.80.10	1
31	000-1154	Snap ring, inner Ø80	1
32	003-0218	Front cover, gearbox	1
33	000-8137	Snap ring, inner Ø90	1
34	000-1018	Bolt HH M14-2.00x45 C8.8 Z P	1
35	000-1077	Washer lock Ø12 Z	2
36	009-1281	Bolt HH M10-1.50x35 C8.8 Z F	2
37	000-1278	Bolt HH M10-1.50x30 C8.8 Z F	5
38	003-0157	Washer fender Ø10 Z	6
39	000-1106	Nut HH M12-1.75 C6 Z MD	2
40	001-1201	Support, guard	1
41	000-6691	Gasket, aluminum	1
	050-0511A	Gearbox 540 rpm, complete; T50-2XX, T50-3XX #313776 & below	-
	050-0512	Gearbox 540 rpm, complete; T50-3XX #313777 & above	-

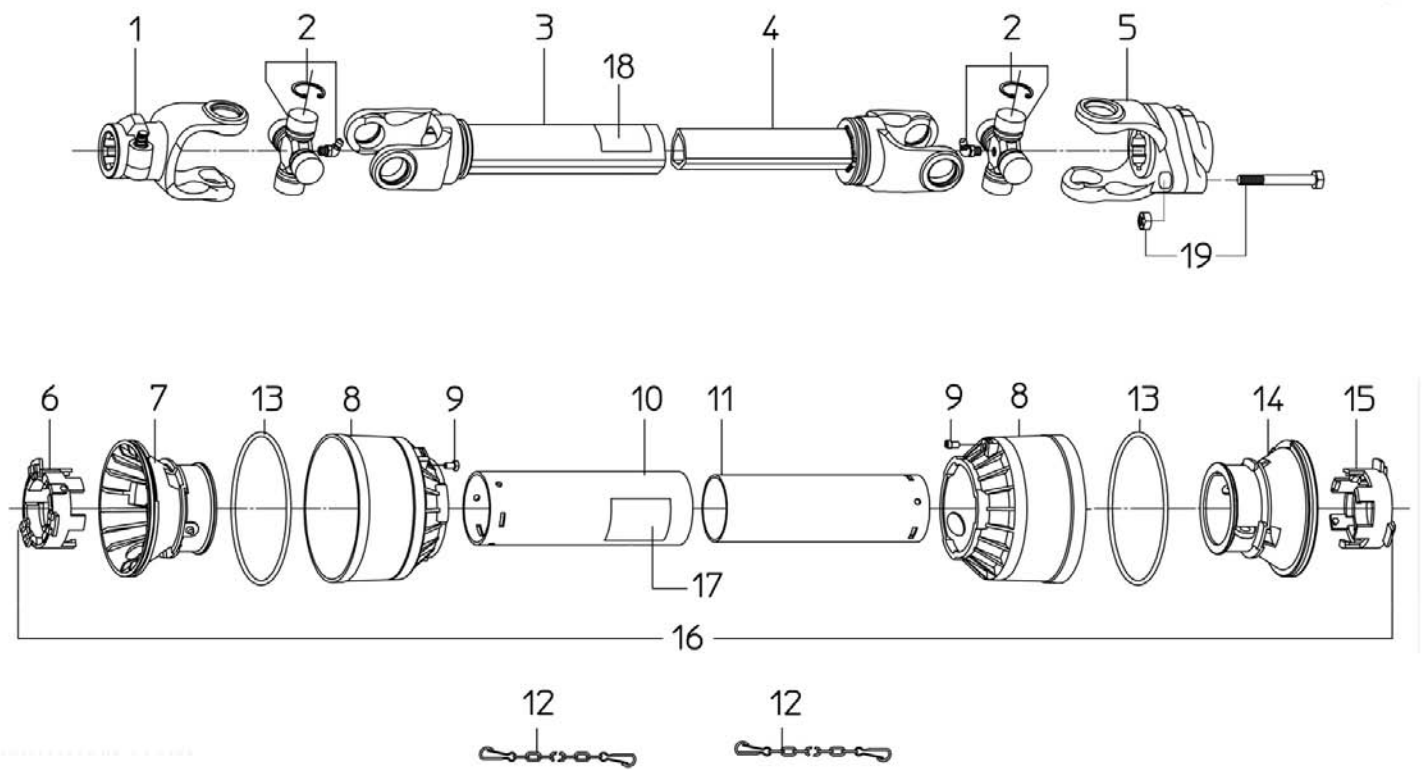

Ref.	Part #	Description	Qty.
1	1024010C	PTO yoke (tractor end)	1
2	1004020C	Cross & bearing	2
3	1944044NC	Outer tube	1
4	1954046NC	Inner tube	1
5	1484037C	Shearpin coupler (implement end)	1
6	1784210C	Locking ring, outer tube	1
7	1784201C	Rigid cone, outer tube	1
8	1784203C	Standard cone	2
9	1784212C	Pin	2
10	1773042C	Shield, outer tube	1
11	1872042C	Shield, inner tube	1
12	1006065C	Chain, anti-rotation	2
13	1213233C	Stiffening ring	2
14	1784202C	Rigid cone, inner tube	1
15	1784211C	Locking ring, inner tube	1
16	90SS4042C	Shield, complete	1
17	950-463B	Decal "DANGER - Rotating driveline, keep away" outer shield	1
18	950-464B	Decal "DANGER - Guard missing, do not operate" outer tube	1
19	000-508E	Shear bolt HH M08-1.25x45 C8.8 N P & nut PT M08-1.25	1
	050-0407	Driveline w/shear bolt, complete	-

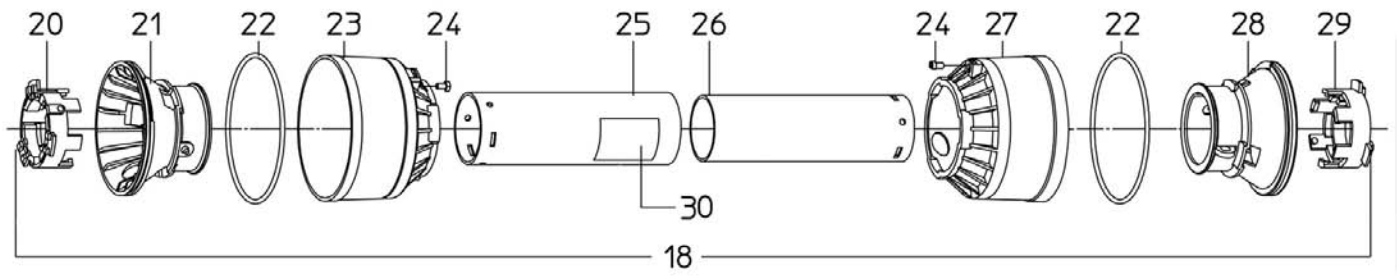
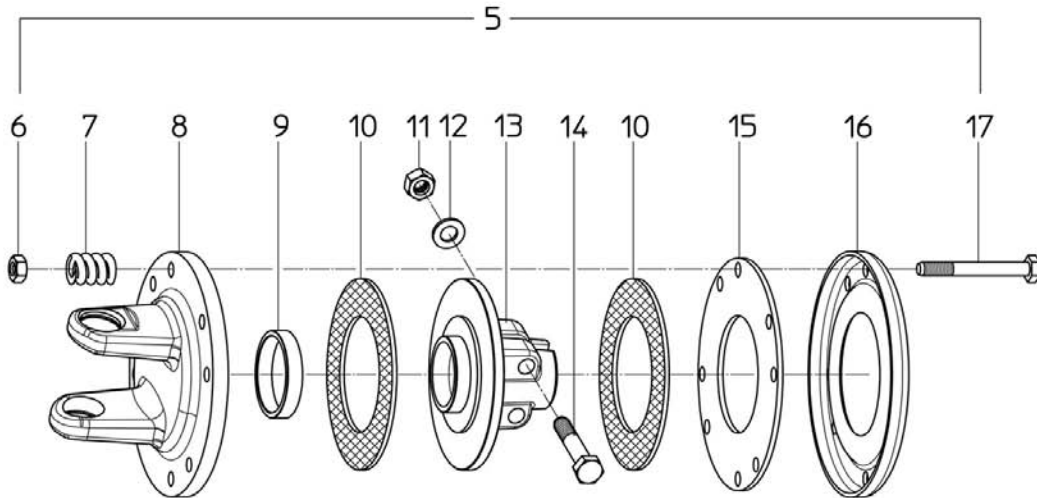
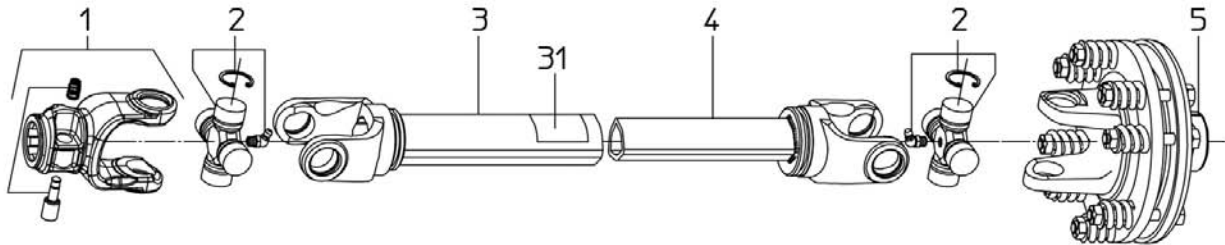

T50-250, 350, 258, 358, 266, 366 SERIAL #292711 & BELOW

Ref.	Part #	Description	Qty.
1	1024010C	PTO yoke (tractor end)	1
2	1004020C	Cross & bearing	2
3	1944038NC	Outer tube	1
4	1954040NC	Inner tube	1
5	1334030C	Slip clutch, complete (implement end)	1
6	003-0156	Nut, PT M10-1.50 C6 ZC	8
7	1215012C	Spring	8
8	1704021C	Yoke, slip clutch	1
9	1704017C	Bushing	1
10	1804000C	Friction disc	2
11	000-1075	Nut, HH M12-1.25 C6 ZC TK	1
12	000-1077	Washer, lock M12 ZC	1
13	1704016C	Body, slip clutch	1
14	003-4270	Bolt, HH M12-1.25x65 C 8.8 Z P	1
15	1134008C	Inner disc	1
16	1134007C	Outer flange	1
17	001-5232	Bolt, HH M10-1.50x75 C 8.8 Z P	8
18	90SE4036C	Shield, complete ²¹	1
19	1006065C	Chain, anti-rotation	2
20	1784210C	Locking ring, outer tube; #292711 & below	1
21	1784201C	Rigid cone, outer tube; #292711 & below	1
22	1213233C	Stiffening ring; #292711 & below	2
23	1784203C	Standard cone; #292711 & below	1
24	1784212C	Pin; #292711 & below	2
25	1773036C	Shield, outer tube	1
26	1872036C	Shield, inner tube	1
27	1784207C	Extra short cone; #292711 & below	1
28	1784202C	Rigid cone, inner tube; #292711 & below	1
29	1784211C	Locking ring, inner tube; #292711 & below	1
30	950-463B	Decal "DANGER - Rotating driveline, keep away" outer shield	1
31	950-464B	Decal "DANGER - Guard missing, do not operate" outer tube	1
	050-0409	Driveline w/slip clutch, complete	-

²¹ Complete shielding is interchangeable with part #96SE4036C. Single shield components are not interchangeable.

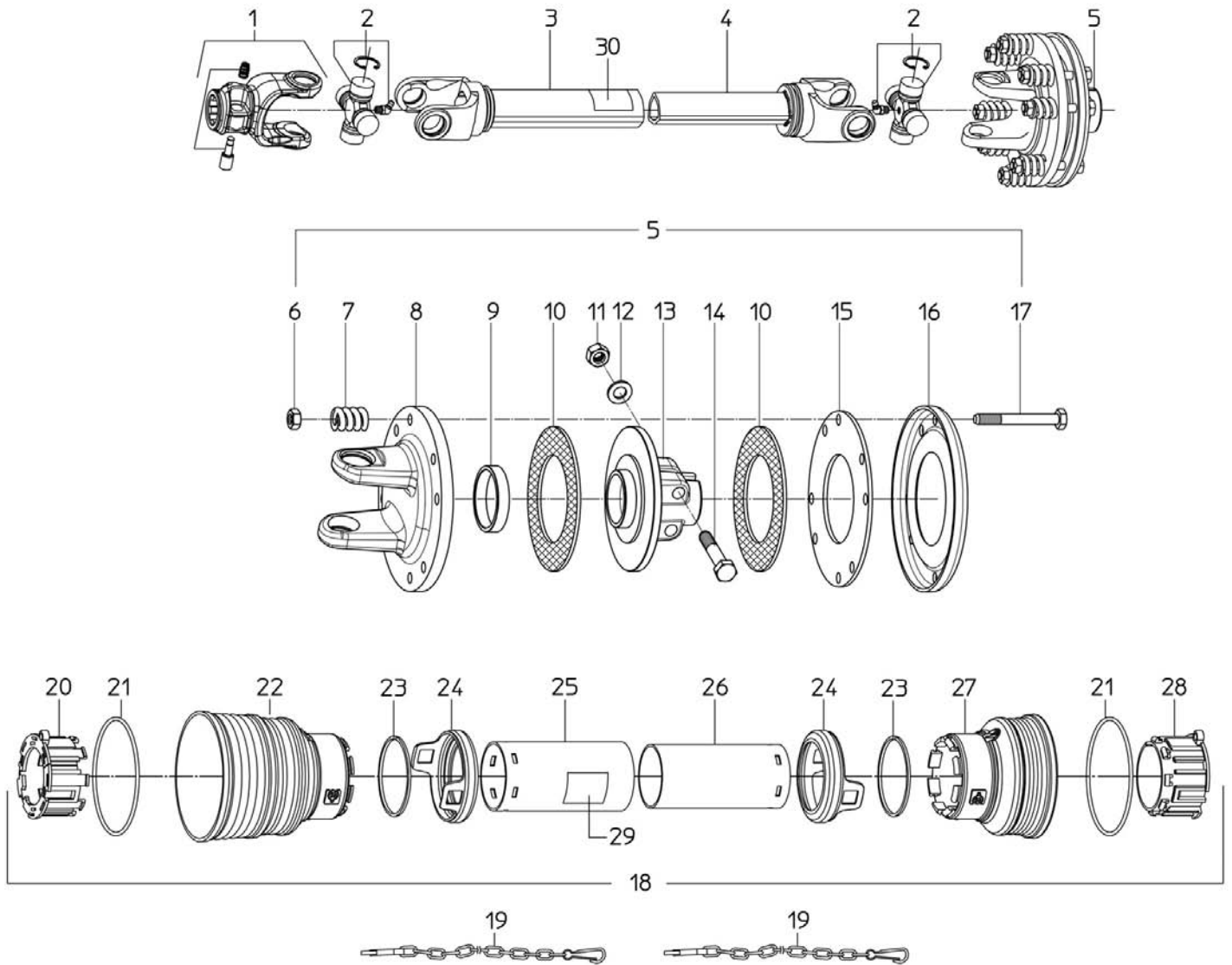

T50-250, 350, 258, 358, 266, 366 SERIAL #292712 & ABOVE

Ref.	Part #	Description	Qty.
1	1024010C	PTO yoke (tractor end)	1
2	1004020C	Cross & bearing	2
3	1944038NC	Outer tube	1
4	1954040NC	Inner tube	1
5	1334030C	Slip clutch, complete (implement end)	1
6	003-0156	Nut PT M10-1.50 C6 ZC	8
7	1215012C	Spring	8
8	1704021C	Yoke, slip clutch	1
9	1704017C	Bushing	1
10	1804000C	Friction disc	2
11	000-1075	Nut HH M12-1.25 C6 ZC TK	2
12	000-1077	Washer lock M12 ZC	2
13	1704016C	Body, slip clutch	1
14	003-4270	Bolt HH M12-1.25x65 C 8.8 Z P	2
15	1134008C	Inner disc	1
16	1134007C	Outer flange	1
17	001-5232	Bolt HH M10-1.50x75 C 8.8 Z P	8
18	96SE4036C	Shield, complete	1
19	1006065C	Chain, anti-rotation	2
20	1784710C	Locking ring, outer tube; #292712 & above	1
21	1211733C	Stiffening ring; #292712 & above	2
22	1781703C	Standard cone; #292712 & above	1
23	1211735C	Stop ring; #292712 & above	2
24	1881709C	Safety sleeve; #292712 & above	2
25	1773036C	Shield, outer tube	1
26	1872036C	Shield, inner tube	1
27	1781701C	Extra short cone; #292712 & above	1
28	1784711C	Locking ring, inner tube; #292712 & above	1
29	950-463B	Decal "DANGER - Rotating driveline, keep away" outer shield	1
30	950-464B	Decal "DANGER - Guard missing, do not operate" outer tube	1
	050-0409	Driveline w/slip clutch complete	-

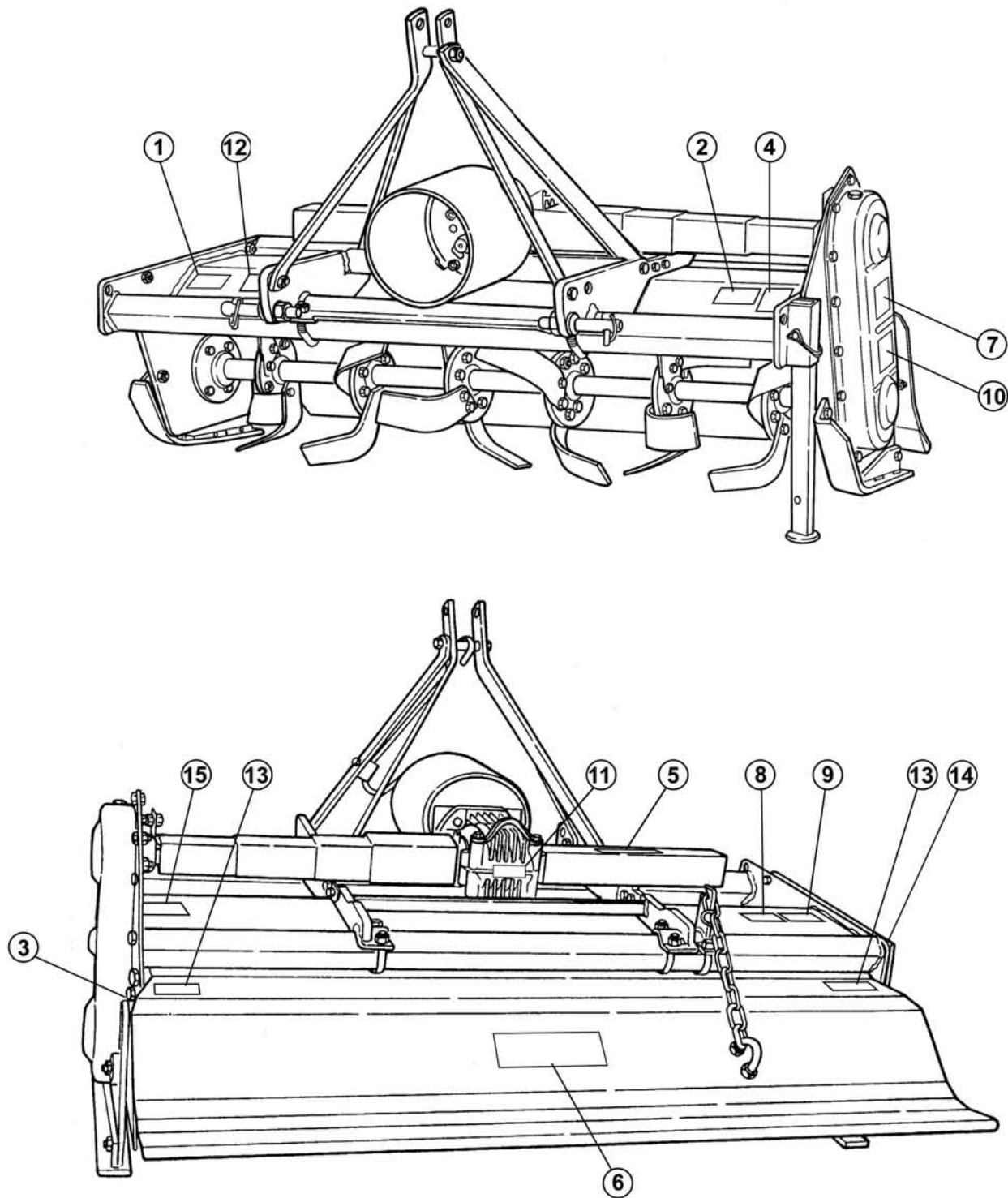

Ref.	Part #	Description	Qty.
1	950-109B	Decal "DANGER - Avoid injury from PTO"	1
2	950-209B	Decal "DANGER - Rotating blades hazard"	1
3	950-486B	Decal "DANGER - Moving parts hazard"	1
4	950-417B	Decal "CAUTION - Read operator's manual"	1
5	937-0160	Decal "Side-shift"	1
6	950-107B	Decal "BEFCO"	1
7	950-226B	Decal "B" logo	1
8	950-232B	Decal "T50"	1
9	950-240B	Decal "250"	1
	950-388B	Decal "350"	1
	950-241B	Decal "258"	1
	950-387B	Decal "358"	1
	950-242B	Decal "266"	1
	950-386B	Decal "366"	1
10	937-0224	Decal "Forward or reverse tilling"	1
11	937-0226	Decal "Oil level"	1
12	950-940B	Decal "Quick hitch compatible"	1
13	950-366B	Decal "Red reflective"	2
14	937-0194	Decal, "grease"	1
15	-	Decal, serial number	1
	971-102B	Operator's & Parts Manual "T50-X50, X58, X66"	1

Use only original spare parts

All rights reserved. It is unlawful to copy, reprint or use any of the information or details in this manual without the expressed written permission of the Company. Technical information provided in this manual is approximate, the Company reserves the right to modify or improve the models shown for technical or commercial purposes. Pictures in this manual do not necessarily show the machine as delivered.

BEFCO[®]

P.O. Box 6036
Rocky Mount, NC 27802-6036
Tel.: 252.977.9920 - Fax: 252.977.9718
www.befco.com

