

ROTOMECH

BABY-HOP

Spandiconcime trainato
Pull type fertilizer spreader
Epandeur d'engrais traîné
Anhänge-Düngerstreuer

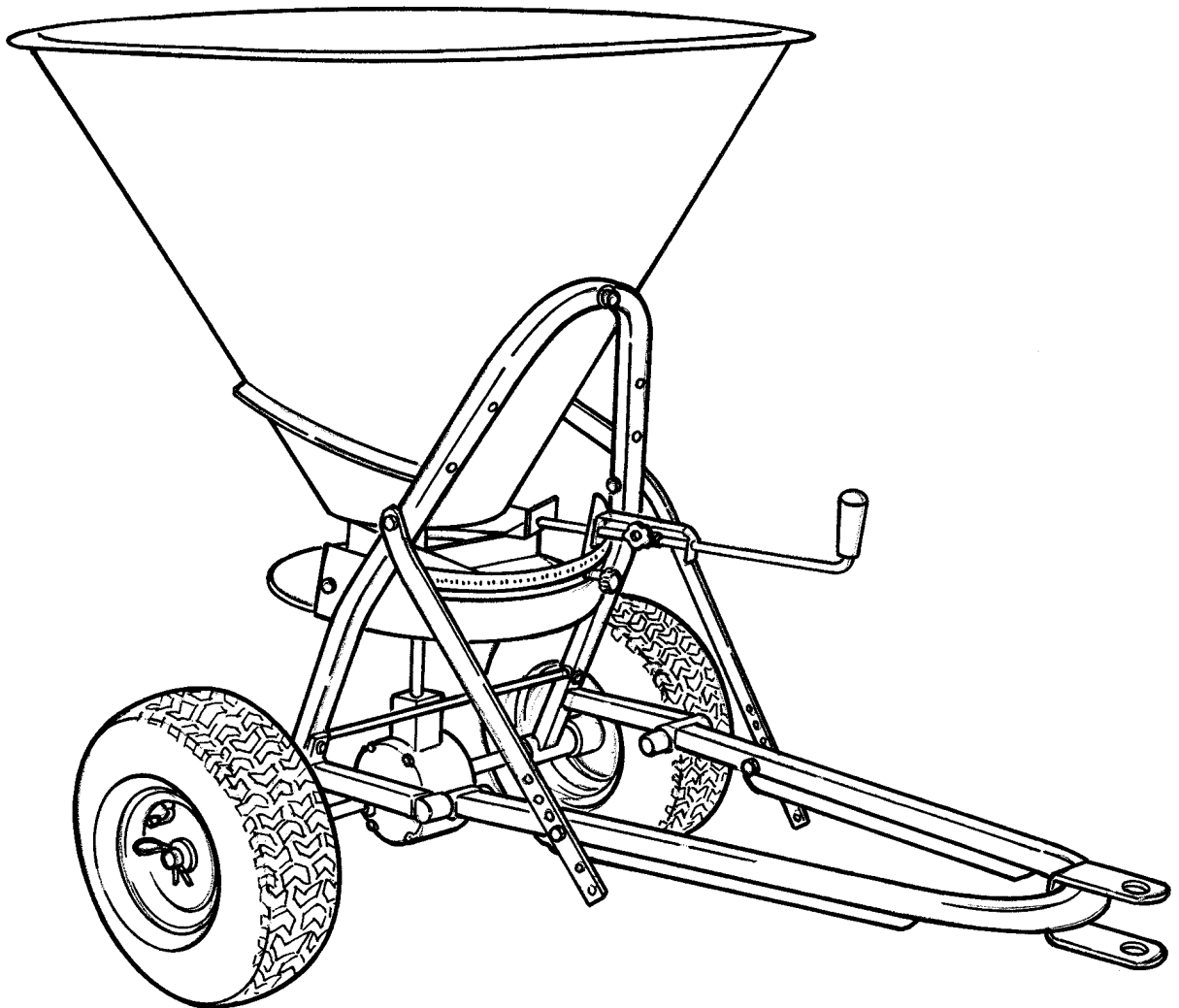

Rotomec: Baby-Hop

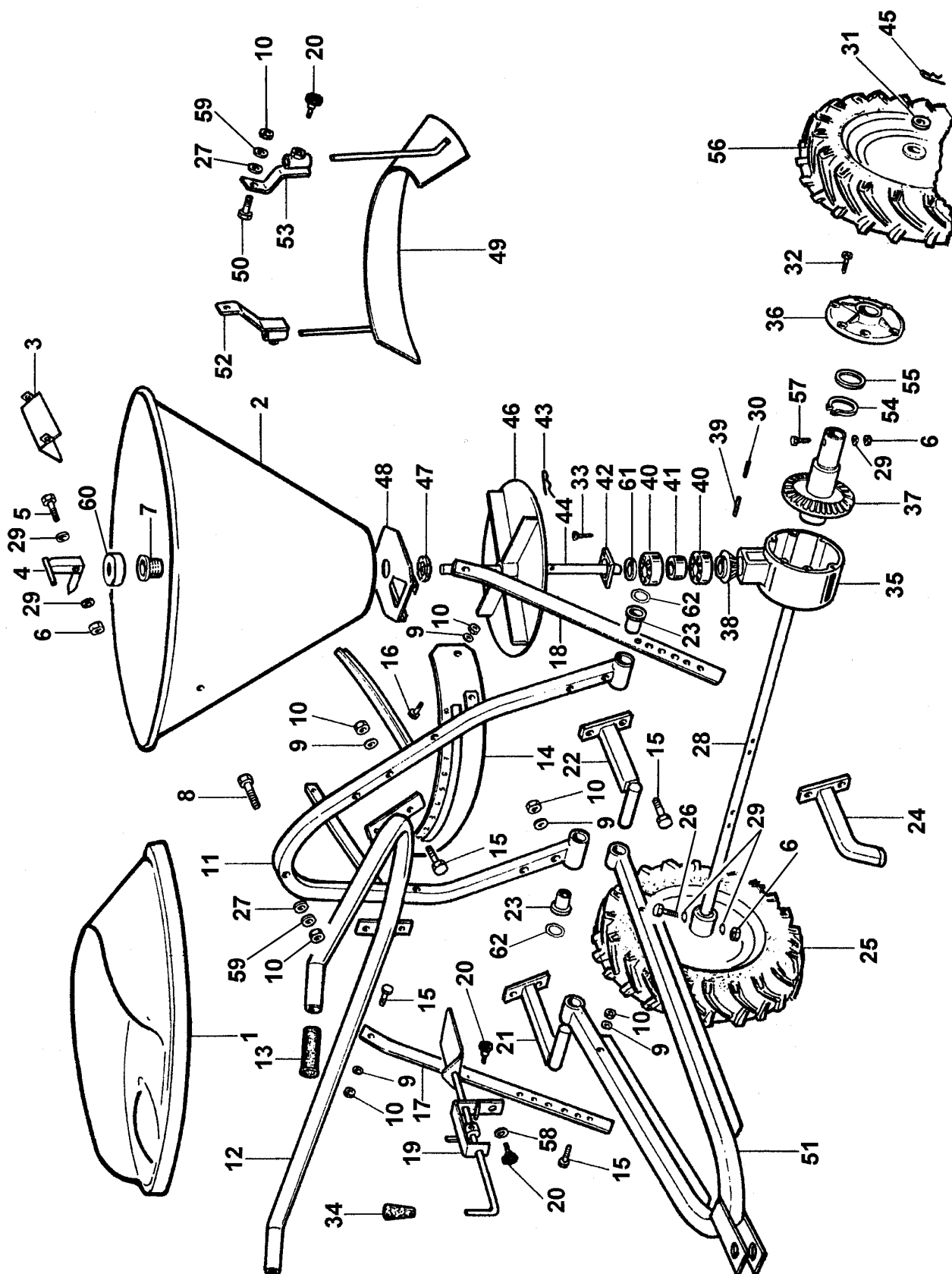

Rotomec: Baby-Hop

N.	COD.	DESCRIZIONE	DESCRIPTION	DESCRIPTION	BESCHREIBUNG	N.
1	501-616B	Sedile per tramoggia v.50	Seat for hopper v.50	Siège trémie v.50	Trichtersitz v.50	1
2	501-617B	Tramoggia v.50	Hopper v.50	Trémie v.50	Trichter v.50	1
	501-618B	Tramoggia v.100	Hopper v.100	Trémie v.100	Trichter v.100	1
	503-882B	Tramoggia v.160	Hopper v.160	Trémie v.160	Trichter v.160	1
3	0014777	Protezione agitatore	Stirrer guard	Protection	Rührerschutzabdeckung	1
4	501-619B	Agitatore	Stirrer	Agitateur	Rührer	1
5	501-620B	Vite TE M6x30	Bolt TE M6x30	Vis TE M6x30	Schraube TE M6x30	1
6	0050165	Dado autobloccante M6	Locking nut M6	Ecrou autobloquant M6	Mutter M6	3
7	502-028B	Boccola filettata	Threaded bushing	Douille	Gewindebüchse	1
8	501-623B	Vite TTQST M8x40	Carriage bolt TTQST M8x40	Vis TTQST M8x40	Schraube TTQST M8x40	1
9	0015230	Rondella piana Ø8	Flat washer Ø8	Rondelle plate Ø8	Flache Scheibe Ø8	10
10	0046545	Dado M8	Nut M8	Ecrou M8	Mutter M8	13
11	501-624B	Telaio v.50-100	Frame v.50-100	Châssis v.50-100	Rahmen v.50-100	1
	503-883B	Telaio v.160	Frame v.160	Châssis v.160	Rahmen v.160	1
12	0103121	Stegola per uso manuale	Handle for manual control	Guidon manuel	Sterz für Handbedienung	1
13	0103122	Manopola per stegola	Handle hand grip	Poignée pour guidon	Handgriffe	2
14	501-625B	Protezione	Guard	Protection	Schutz	1
15	501-626B	Vite TE M8x40	Bolt TE M8x40	Vis TE M8x40	Schraube TE M8x40	8
16	0015012	Vite TE M8x20	Bolt TE M8x20	Vis TE M8x20	Schraube TE M8x20	2
17	501-628B	Asta destra per registro timone	Right hitch adjustment	Tige droit	Rechte Stange zur Deichseleinstellung	1
18	501-629B	Asta sinistra per registro timone	Left hitch adjustment	Tige gauche	Linke Stange zur Deichseleinstellung	1
19	501-630B	Gruppo registro portina	Shutter lever	Groupe de réglage	Türeinsteilaggregat	1
20	501-631B	Volantino M6x16	Adjustment knob M6x16	Vis de fixation M6x16	Stellschraube M6x16	2
21	501-632B	Attacco timone destra	Right hitch connection	Attache droit	Rechte Deichselankupplung	1
22	501-633B	Attacco timone sinistra	Left hitch connection	Attache gauche	Linke Deichselankupplung	1
23	502-029B	Boccola nylon Ø21 v.50-100	Nylon bushing Ø21 v.50-100	Douille en nylon Ø21 v.50-100	Büchse aus Nylon Ø21 v.50-100	2
	502-029B	Boccola nylon Ø21 v.160	Nylon bushing Ø21 v.160	Douille en nylon Ø21 v.160	Büchse aus Nylon Ø21 v.160	4
24	0103123	Piede appoggio	Stand	Pied de soutien	Auflagefuß	2
25	0014875	Ruota gommata piena destra v.50-100	Right hard tire v.50-100	Roue caoutchoutée droit v.50-100	Rechtes Gummirad v.50-100	1
	501-999B	Ruota pneumatica 13"x6" v.50-100	Air tire 13"x6" v.50-100	Roue pneumatique 13"x6" v.50-100	Luftreifen 13"x6" v.50-100	1
	503-884B	Ruota pneumatica 16"x8" v.160	Air tire 16"x8" v.160	Roue pneumatique 16"x8" v.160	Luftreifen 16"x8" v.160	1
	0014878	Boccola per ruote (non illustrata)	Bushing for tire (not shown)	Douille pour roue (pas indiquée)	Büchse (nicht gezeigt)	2
26	0014862	Vite TE M6x45	Bolt TE M6x45	Vis TE M6x45	Schraube TE M6x45	1
27	0014514	Rondella piana Ø8x24	Flat washer Ø8x24	Rondelle plate Ø8x24	Flache Scheibe Ø8x24	3
28	502-032B	Assale v.50-100	Axle v.50-100	Assieu v.50-100	Achse v.50-100	1
	503-682B	Assale v.160	Axle v.160	Assieu v.160	Achse v.160	1
29	0050166	Rondella piana Ø6	Flat washer Ø6	Rondelle plate Ø6	Flache Scheibe Ø6	5
30	502-034B	Spina elastica Ø3x20	Roll pin Ø3x20	Goupille élastique Ø3x20	Spannstift Ø3x20	1
31	0046555	Rondella piana Ø20	Flat washer Ø20	Rondelle plate Ø20	Flache Scheibe Ø20	2
32	502-035B	Vite NTC 3,9x25	Self tapping screw NTC 3,9x25	Vis NTC 3,9x25	Schraube NTC 3,9x25	6
33	502-036B	Vite NTC 3,9x16	Self tapping screw NTC 3,9x16	Vis NTC 3,9x16	Schraube NTC 3,9x16	4
34	501-639B	Pomello registro portina	Adjustment knob	Pommeau de réglage	Türeinsteilgriff	1

Rotomec: Baby-Hop

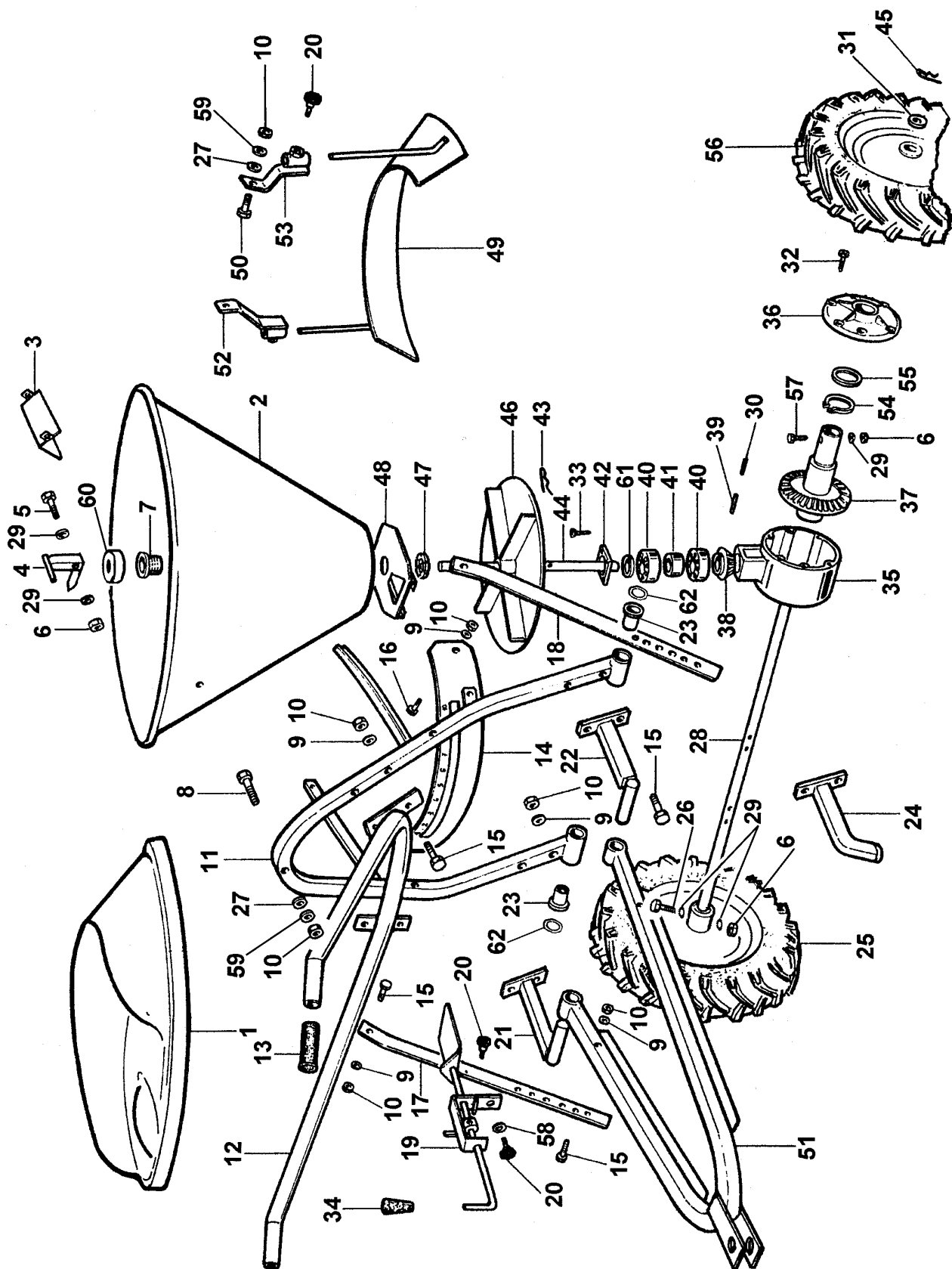

Rotomec: Baby-Hop

N.	COD.	DESCRIZIONE	DESCRIPTION	DESCRIPTION	BESCHREIBUNG	N.
35	502-037B	Corpo scatola	Gearbox housing	Boîte	Gehäusegruppe	1
36	502-038B	Coperchio grande scatola	Gearbox cover	Couvercle boîte	Abdeckung des großen Gehäuses	1
37	502-039B	Corona	Bevel gear	Couronne	Tellerad	1
38	502-040B	Pignone	Pinion gear	Pignon	Kegelrad	1
39	501-644B	Spina elastica Ø5x20	Roll pin Ø5x20	Goupille élastique Ø5x20	Spannstift Ø5x20	1
40	501-645B	Cuscinetto 6202-ZZ	Bearing 6202-ZZ	Roulement 6202-ZZ	Lager 6202-ZZ	2
41	502-041B	Distanziale	Spacer	Entretoise	Distanzstück	1
42	502-042B	Coperchio collare scatola	Gearbox top cover	Couvercle boîte	Abdeckung am Gehäuseering	1
43	0041291	Copiglia a molla Ø5	Cotter pin Ø5	Goupille ressort Ø5	Federsplint Ø5	1
44	502-043B	Albero uscita	Outgoing shaft	Arbre	Abtriebswelle	1
45	0014871	Copiglia a molla Ø4	Cotter pin Ø4	Goupille ressort Ø4	Federsplint Ø4	2
46	502-044B	Disco spanditore	Spreader disc	Disque de distribution	Streuscheibe	1
47	501-651B	Dado M30 BPF	Nut M30 BPF	Ecrou M30 BPF	Mutter M30 BPF	1
48	501-652B	Portina mobile	Mobile shutter	Plaque de réglage	Bewegliche Tür	1
49	501-653B	Deflettore per regolazione	Deflector shield	Déflexeur pour le réglage	Umlenklech zur Einstellung	1
50	501-663B	Vite TTQST M8x25	Carriage bolt TTQST M8x25	Vis TTQST M8x25	Schraube TTQST M8x25	2
51	501-655B	Timone per traino	Towing hitch	Timon	Zugdeichsel	1
52	502-045B	Attacco deflettore destro	Right deflector connection	Attelage déflexeur droit	Rechte Umlenklechankupplung	1
53	502-046B	Attacco deflettore sinistro	Left deflector connection	Attelage déflexeur gauche	Linke Umlenklechankupplung	1
54	0010122	Seeger esterno Ø30	Outer snap ring Ø30	Circlip externe Ø30	Außenseegerring Ø30	1
55	0014896	Spessore Ø30x42x0,5	Shim Ø30x42x0,5	Entretoise Ø30x42x0,5	Distanzstück Ø30x42x0,5	1
56	0014876	Ruota gommata piena sinistra v.50-100	Left hard tire v.50-100	Roue caoutchoutée gauche v.50-100	Linkes Gummirad v.50-100	1
	501-999B	Ruota pneumatica 13"x6" v.50-100	Air tire 13"x6" v.50-100	Roue pneumatique 13"x6" v.50-100	Luftreifen 13"x6" v.50-100	1
	503-884B	Ruota pneumatica 16"x8" v.160	Air tire 16"x8" v.160	Roue pneumatique 16"x8" v.160	Luftreifen 16"x8" v.160	1
	0014878	Boccola per ruote (non illustrata)	Bushing for tire (not shown)	Douille pour roue (pas indiquée)	Büchse (nicht gezeigt)	2
57	0052418	Vite TE M6x40	Bolt TE M6x40	Vis M6x40	Schraube M6x40	1
58	0011209	Rondella piana Ø6x18	Flat washer Ø6x18	Rondelle plate Ø6x18	Flache Scheibe Ø6x18	1
59	0003144	Rosetta elastica Ø8	Spring washer Ø8	Rondelle élastique Ø8	Sprengring Ø8	3
60	0014810	Coperchiella fino 12/2013	Cover until 12/2013	Couvercle jusqu'à 12/2013	Deckel bis 12/2013	1
61	0014885	Paraolio 16.24.5 dal 01/10/05	Oil seal 16.24.5 since 01/10/05	Pare-huile 16.24.5 dès 01/10/05	Simmering 16.24.5 ab 01/10/05	1
62	0014873	Spessore Ø20x28x0,3	Shim Ø20x28x0,3	Entretoise Ø20x28x0,3	Distanzstück Ø20x28x0,3	2
	502-051B	Scatola ingranaggi completa	Complete gearbox	Boîtier	Gehäusegruppe	1

Rotomec: Baby-Hop

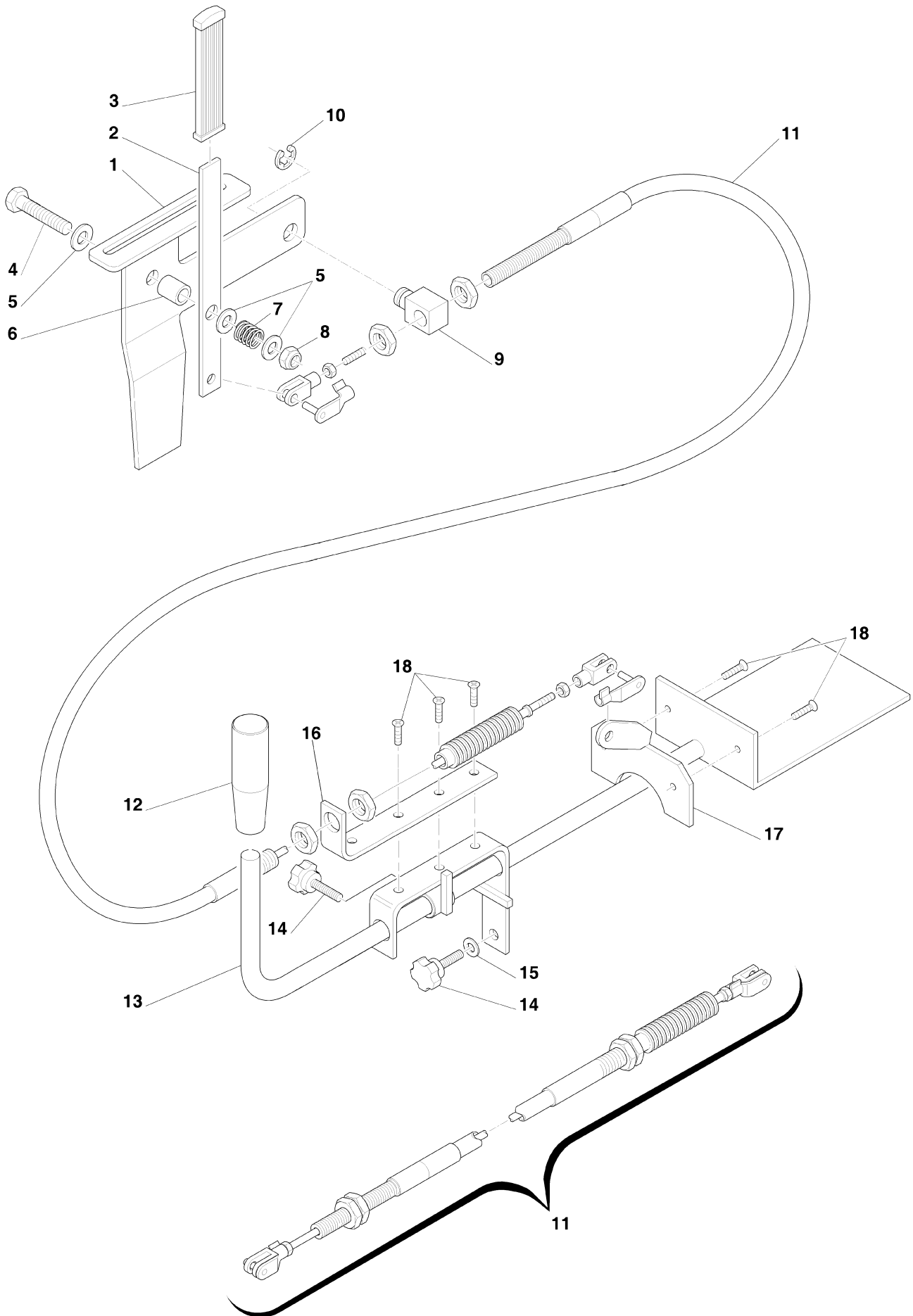

Rotomec: Baby-Hop

N.	COD.	DESCRIZIONE	DESCRIPTION	DESCRIPTION	BESCHREIBUNG	N.
1	0014981	Piastra supporto leva comando	Support plate for remote control	Plaque support levier	Hebelsupportsplatte	1
2	0014982	Leva di comando	Remote control lever	Levier commande à distance	Fernanlaßbedienungshebel	1
3	0014983	Manopola piatta rigata	Flat grooved handle	Poignée plate gouffrée	Flacher geschlitzte Handgriff	1
4	0014477	Vite TE M10x60	Bolt TE M10x60	Vis TE M10x60	Schraube TE M10x60	1
5	0002034	Rondella piana Ø10	Flat washer Ø10	Rondelle plate Ø10	Flache Scheibe Ø10	3
6	0014988	Distanziale	Spacer	Entretoise	Distanzstück	1
7	0014989	Molla	Spring	Ressort	Feder	1
8	0015237	Dado autobloccante M10	Locking nut M10	Ecrou autobloquant M10	Mutter M10	1
9	0014990	Sostegno per cavo	Cable support	Support câble	Kabelsupport	1
10	0014991	Seeger esterno Ø10	Outer snap ring Ø10	Circlip externe Ø10	Außenseegerring Ø10	1
11	0014992	Cavo	Cable	Câble	Kabel	1
	0014997	Cavo dal 09/08	Cable since 09/08	Câble dès 09/08	Kabel ab 09/08	1
12	501-639B	Pomello registro portina	Adjustment knob	Pommeau de réglage	Türeinsteilgriff	1
13	0014999	Gruppo registro portina	Flow control assembly	Groupe de réglage	Türeinsteilaggregat	1
14	501-631B	Volantino M6x16	Adjustment knob M6x16	Vis de fixation M6x16	Stellschraube M6x16	2
15	0011209	Rondella piana Ø6x18	Flat washer Ø6x18	Rondelle plate Ø6x18	Flache Scheibe Ø6x18	1
16	0014993	Piatto di sostegno per cavo	Cable supporting plate	Plate support câble	Kabelsupportplatte	1
17	0014994	Piastra attacco terminale cavo	Cable hitch plate	Plaque attelage câble	Kabelanschlußplatte	1
18	0014998	Vite TSPEI M4x10	Bolt TSPEI M4x10	Vis TSPEI M4x10	Schraube TSPEI M4x10	5

