

ROTOMECH

Operator's Manual

GREEN-RITE

**One Pass Overseeder-Aerator and/or
Seeder-Cultivator with Corrugated Roller for
Lawn and Turf Operations**

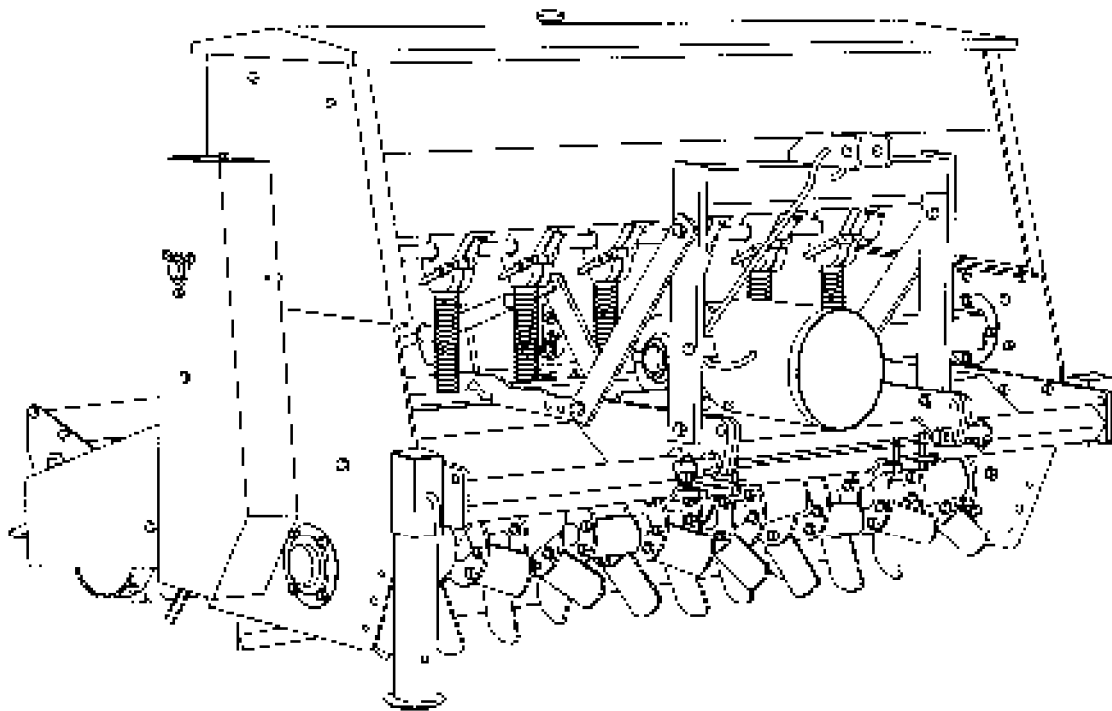

The operator's manual is a technical service guide and must always accompany the machine.

SAFETY

Take note! This safety alert symbol found throughout this manual is used to call your attention to instructions involving your personal safety and the safety of others. Failure to follow these instructions can result in injury or death.



*This symbol means:
ATTENTION!
BECOME ALERT!
YOUR SAFETY IS INVOLVED!*

Signal Words

Note the use of the signal words DANGER, WARNING and CAUTION with the safety messages. The appropriate signal words for each has been selected using the following guidelines:



DANGER: indicates an imminently hazardous situation that, if not avoided, will result in death or serious injury.



WARNING: indicates a potentially hazardous situation that, if not avoided, could result in death or serious injury, and includes hazards that are exposed when guards are removed. It may also be used to alert against unsafe practices.

SAFETY



CAUTION: indicates a potentially hazardous situation that, if not avoided, may result in minor or moderate injury.

ROTOMECH

Operator's Manual

GREEN-RITE

**One Pass Overseeder-Aerator and/or
Seeder-Cultivator with Corrugated Roller for
Lawn and Turf Operations**

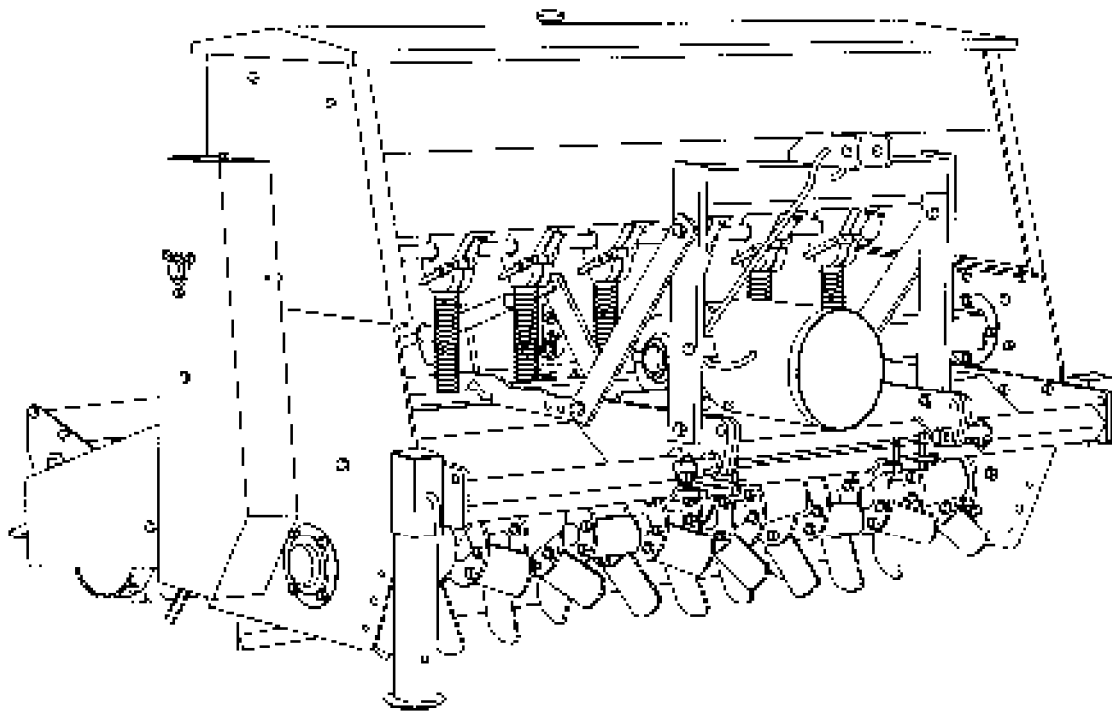

The operator's manual is a technical service guide and must always accompany the machine.

INDEX

1 - GENERAL INFORMATION	5
1.01 - General	5
1.02 - Model and Serial Number ID	5
2 - SAFETY PRECAUTIONS	7
2.01 - Preparation	7
2.02 - Starting and Stopping	8
2.03 - Messages and Signs	8
3 - OPERATION	10
3.01 - Operational Safety	10
3.02 - Set-up	12
3.03 - Rear Tailgate Adjustment	13
3.04 - Tickler Tine Adjustment	13
3.05 - Corrugated Roller Adjustment	14
3.06 - Front Roller Adjustment	15
3.07 - Front Wheels Adjustment	16
3.08 - Hopper Adjustment	16
3.09 - Seed (or Fertiliser) Hopper Calibration	18
3.10 - Driveline	20
3.11 - Safety Slip Clutch	21
3.12 - Pre-Operational Check	21
3.13 - Attaching to the Tractor	22
3.14 - Start Up	23
3.15 - Test Run	25
3.16 - Working Depth	25
3.17 - Working Speed	25
3.18 - Headland Procedure	26
3.19 - Working Limitations	26
3.20 - Uneven Terrain	26
3.21 - Transporting	27
4 - MAINTENANCE	28
4.01 - Maintenance Safety	28
4.02 - Service	29
4.03 - Changing Rotors	31
4.04 - Blade Maintenance	32
5 - REPAIR PROCEDURES	34
5.01 - Gearbox	34
5.02 - Chain Case	34
5.03 - Removing the Rotor	34
5.04 - Suggested Spare Parts	35
5.05 - Storage	35
6 - TROUBLESHOOTING	36
7 - PRE-DELIVERY CHECKLIST	37
8 - WARRANTY	38

1 - GENERAL INFORMATION

Thank you and congratulations for having chosen our implement. Your new Green-Rite is a technologically advanced machine constructed of high quality, sturdy components and will fulfil your working expectations.

The Green-Rite is the ideal machine for sport fields, parks, golf courses, airports, turf farm operations and anywhere the combination of lower labour costs and a professionally finished job is essential.

Read this manual carefully. It will instruct you on how to operate and service your implement safely and correctly. Failure to do so could result in personal injury and/or equipment damage.

1.01 - General





CAUTION: all hardware is metric. Only metric tools should be used. Other tools that do not fit properly can slip and cause injury.



CAUTION: right hand and left hand sides of the implement are determined by facing in the direction the implement will travel when going forward (see fig. 2).

1.02 - Model and Serial Number ID

Attached to the frame is an ID plate showing the model and serial number (see below). Record your implement model and serial number in the space provided below. Your dealer needs this information to give you prompt, efficient service when you order parts.

 ROTOMECC S.p.A. 37054 NOGARA (VERONA) ITALY PH.: 39.(0).442.510400 r.a.		
KW.	KG.	YEAR

Carefully read the warranty section¹ detailing coverage and limitations of this warranty. **Warranty** is provided for customers who operate and maintain their equipment as described in this manual. Warranty registration is accomplished by the dealer completing and forwarding the **Warranty Registration Form** to the Company, along with a copy of the dealer's invoice. It is in your best interest to insure that this has been done.

Warranty does not cover the following:

1. cleaning, transporting, mailing and service call charges.
2. Normal wear items such as belts, blades, bearings, drive lines, shear pins, slip clutches, tires, etc.
3. Depreciation or damage caused by normal wear, accidents, improper maintenance, improper protection or improper use.
4. The use of non original spare parts and accessories.

Your Authorised Company Dealer has genuine parts in stock. Only these approved replacement parts should be used.

This limited warranty covers defective material and workmanship. The cost of normal maintenance or repairs for accidents or improper use and related labour will be borne by the owner.

¹ See chapter 8 - Warranty.

2 - SAFETY PRECAUTIONS

Safety is the primary concern in the design and manufacture of our products. Unfortunately our efforts to provide safe equipment can be wiped out by a single careless act of an operator.

In addition to the design and configuration of equipment, hazard control and accident prevention are dependent upon the awareness, concern, prudence and proper training of personnel involved in the operation, transport, maintenance and storage of equipment.

It is the operator's responsibility to read and understand all safety and operating instructions in the manual and to follow these.

Allow only properly trained personnel to operate the machine. Working with unfamiliar equipment can lead to careless injuries. Read this manual, and the manual for your tractor, before assembly or operating, to acquaint yourself with the machines. It is the implement owner's responsibility, if this machine is used by any person other than yourself, is loaned or rented, to make certain that the operator, prior to operating, reads and understands the operator's manuals and is instructed in safe and proper use.

2.01 - Preparation



1. Before operating equipment read and understand the operator's manual and the safety signs (see fig. 2).
2. Thoroughly inspect the implement before initial operation to assure that all packaging materials, i.e. wires, bands, and tape have been removed.
3. Personal protection equipment including hard hat, safety glasses, safety shoes, and gloves are recommended during assembly, installation, operation, adjustment, maintaining and/or repairing the implement.
4. Operate the machine only with a tractor equipped with an approved Roll-Over-Protective-System (ROPS). Always wear your seat belt. Serious injury or even death could result from falling off the tractor.
5. Clear area to be cut of stones, branches or other debris that might be thrown, causing injury or damage.
6. Operate only in daylight or good artificial light.
7. Ensure equipment is properly mounted, adjusted and in good operating condition.
8. Ensure that all safety shielding and safety signs are properly installed and in good condition.

2.02 - Starting and Stopping



1. Be sure that no one is near the machine prior to engaging or while the machine is working.
2. Be sure the tractor is in %Neutral+before starting engine.
3. Equipment operating power is supplied from tractor PTO. Refer to your tractor manual for PTO engagement and disengagement instructions. Always operate PTO at 540 rpm. Know how to stop the tractor and machine quickly in case of an emergency.
4. When engaging PTO, the engine rpm should always be low. Once engaged and ready to start working, raise PTO speed to 540 rpm and maintain throughout operation.
5. Check the tractor master shield over the PTO stub shaft. Make sure it is in good condition and fastened securely to the tractor. Purchase a new shield if old shield is damaged or missing.
6. After striking an obstacle, disengage the PTO, shut the tractor down and thoroughly inspect for damage before restarting.
7. Never engage the PTO until the machine is in the down position and resting on the ground. Never raise the machine until the rotor has come to a complete stop.

2.03 - Messages and Signs



1. Read and adhere to all safety and operating decals on this machine (**see fig. 2**).
2. Before dismounting tractor: allow moving parts to stop, stop engine, set brake and remove the key of unattended equipment.
3. Keep away from rotating blades and driveline.
4. Keep guards and shields in place and in good condition.
5. Do not use with bystanders in area.
6. Allow no riders on tractor or machine.
7. Allow moving parts to stop before repair.
8. Securely support equipment before working underneath.

Additional warning and operating decals are available at no extra charge. Please specify model and serial number when ordering.

Fig. 2 - Safety decals; replace immediately if damaged.

- 1. Read this manual carefully.**
- 2. Before maintenance operations, disengage PTO and shut tractor down.**
- 3. 540 rpm PTO only.**
- 4. Keep away from rotating driveline.**
- 5. Keep away, thrown objects.**
- 6. Never allow passengers.**
- 7. Keep all shields in place.**
- 8. Keep away from rotating blades.**

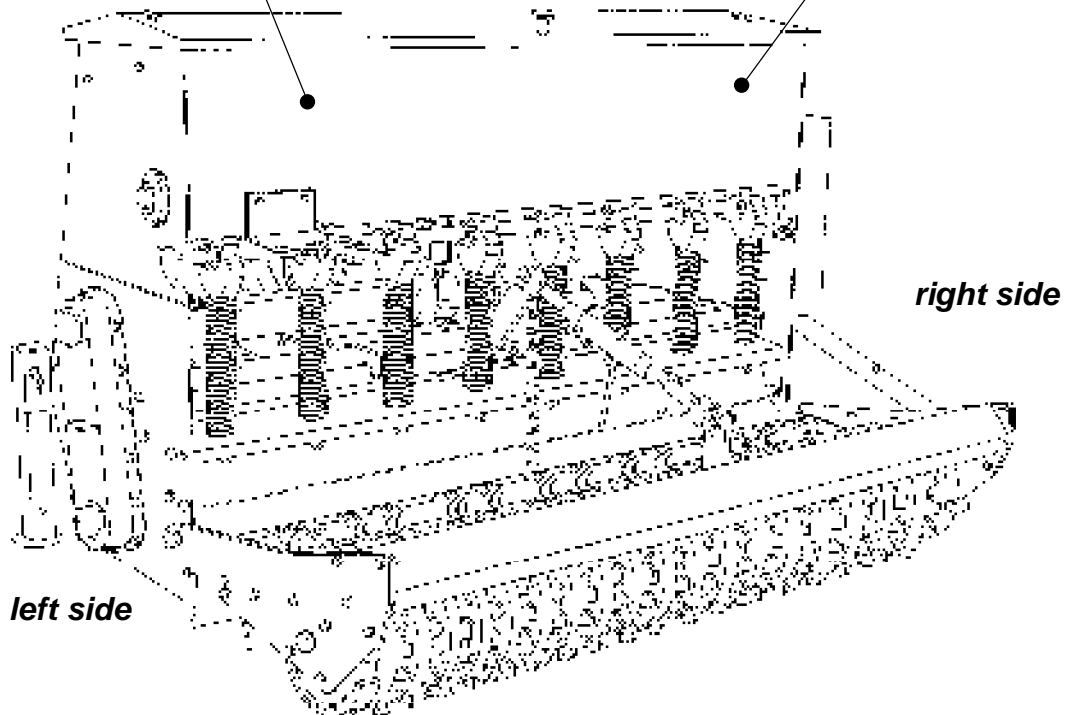
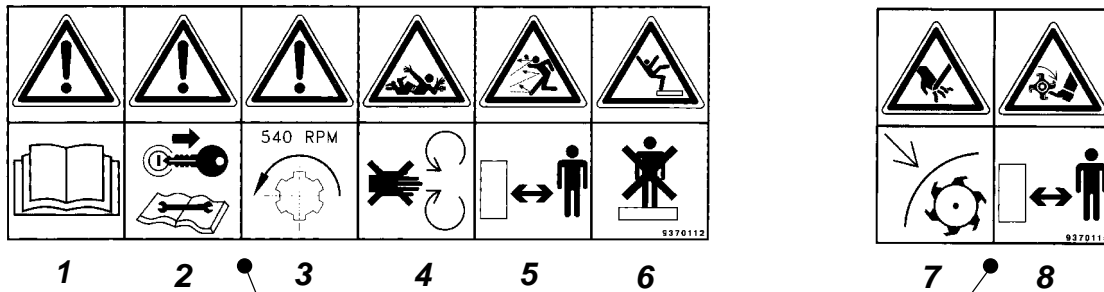

3 - OPERATION

The Green-Rite, engineered at Befco, Inc., our sister Company in the United States, is a one pass tool which aerates, seeds (or broadcasts fertiliser), levels, and compacts the soil for improved seed germination.

A tilling rotor with %C+blades is available upon request, and may be mounted in place of the straight blade aerator rotor. This converts the Green-Rite into a tiller for seed bed preparation which tills, seeds and compacts the soil in a single pass. Changing the machine over from an aerator to a tiller is a simple operation which can be performed in under 30 minutes with a pair of wrenches.

This unique machine reduces costs for grounds maintenance of sports fields, parks, highways, hospital grounds, golf courses, etc. The Green-Rite can easily pay for itself within the first few days of use.

It consists of an aerator rotor with straight blades on narrowly spaced flanges, powered by the tractor PTO. A large capacity seed hopper with precise metering cups is mounted on the base aerator and broadcasts the seed behind the slicing action of the tines along the entire working width of the machine. Tickler tines follow to help incorporate the seed into the ground through compacted soil and thatch. A corrugated roller with fibreglass rings follows behind the Green-Rite to compact the ground for optimal seed germination.

Depth control wheels with wide garden style tread or a front roller may be quickly mounted to ensure a constant depth over unlevelled terrain.

The Green-Rite comes in working widths of 145, 165 and 205 cm. (58+, 66+ and 82+ respectively).

3.01 - Operational Safety



CAUTION: our machines are designed considering safety as the most important target and are the safest available in today's market. Unfortunately, human carelessness can override the safety features built into our machines. Injury prevention and work safety, aside from the features on our machines, is very much due to the responsible use of the equipment. It must always be operated prudently following with great care, the safety instructions laid out in this manual.



1. The use of this equipment is subject to certain hazards which cannot be prevented by mechanical means or product design. All operators of this equipment must read and understand this entire manual, paying particular attention to safety and operating instructions, prior to using.

2. Do not operate the tractor and machine when you are tired, sick or when using medication.
3. Only use this model implement with 540 rpm tractors with horsepower in the correct power range².
4. Keep all helpers and bystanders at least several meters from a rotary cultivator. Only properly trained people should operate this machine.
5. When this machine is operated in populated areas where thrown objects could injure persons or property, standard equipment safety shielding (which is designed to reduce the possibility of thrown objects) must be installed.
6. The majority of accidents involve entanglements on the driveline, injury of bystanders by objects thrown by the rotating blades, and operators being knocked off the tractor by low hanging limbs and then being run over by the equipment. Accidents are most likely to occur with machines that are loaned or rented to someone who has not read the operator's manual and is not familiar with a rotary cultivator.
7. Always stop the tractor, set brake, shut off the tractor engine, remove the ignition key, lower implement to the ground and allow blades to come to a complete stop before dismounting tractor. Never leave equipment unattended with the tractor running.
8. Never place hands or feet under the implement with tractor engine running or before you are sure all motion has stopped. Stay clear of all moving parts.
9. Do not reach or place yourself under equipment until it is blocked securely.
10. Do not allow riders on the machine or tractor at any time. There is no safe place for riders.
11. Do not operate unless all personnel, livestock and pets are several meters away to prevent injury by thrown objects.
12. Before backing up, disengage the implement and look behind carefully.
13. Install and secure all guards and shields before starting or operating.
14. Keep hands, feet, hair and clothing away from moving parts.
15. This implement is designed for use only on tractors with 540 rpm power take off.
16. Never operate tractor and implement under trees with low hanging limbs. Operators can be knocked off the tractor and then run over by the rotating blades.
17. The rotating parts of this machine have been designed and tested for rugged use. However, they could fail upon impact with heavy, solid objects such as steel guard rails and concrete abutments. Such impact could cause the broken objects to be thrown outward at very high velocities. To reduce the possibility of property damage, serious injury, or even death, never allow the cutting blades to contact such obstacles.
18. Frequently check blades. They should be sharp, free of nicks and cracks and securely fastened.
19. Stop machine immediately upon striking an obstruction. Turn engine off, remove key, inspect and repair any damage before resuming operation.
20. Stay alert for holes, rocks and roots in the terrain and other hidden hazards. Keep away from drop-offs.

² See table 5, page 32.

21. Use extreme care and maintain minimum ground speed when transporting on hillside, over rough ground and when operating close to ditches or fences. Be careful when turning sharp corners.
22. Reduce speed on slopes and sharp turns to minimise tipping or loss of control. Be careful when changing directions on slopes. Do not start or stop suddenly on slopes. Avoid operation on steep slopes.
23. When using a unit, a minimum 20% of tractor and equipment weight must be on tractor front wheels. Without this weight, tractor could tip over, causing personal injury or death. The weight may be attained with a front end loader, front wheel weights, ballast in tires or front tractor weights. When attaining a minimum 20% of tractor and equipment weight on the front wheels, you must not exceed the ROPS weight certification. Weigh the tractor and equipment. Do not guess or estimate!
24. Inspect the entire machine periodically³. Look for loose fasteners, worn or broken parts.
25. Use only the driveline supplied with the machine. Do not use it if it is missing any shield or safety protection.
26. Pass diagonally through sharp dips and avoid sharp drops to prevent hanging up tractor and machine.
27. Avoid sudden starts and stops while travelling up or downhill.
28. Always use down slopes; never across the face. Avoid operation on steep slopes. Slow down on sharp turns and slopes to prevent tipping and or loss of control.

3.02 - Set-up

Notice to dealer: pre-delivery set-up and service including lubrication is the responsibility of the authorised dealer. It is up to you to assure that the machine is in perfect condition and ready to be used. It is your responsibility to ensure that the customer is aware of all safety aspects and operational procedures for the machine. You must also fill out the Pre-delivery Checklist⁴ prior to delivering the machine.



CAUTION: stand clear of bands when cutting as they could be under sufficient tension to cause them to fly loose. Take care in removing bands and wire. They often have extremely sharp edges and cut very easily.

Although the machine usually arrives set up, ready to use, it is important to check certain aspects of the machine before using it. Adjustments are normally necessary in order to adapt the Green-Rite to work under a given condition.

Check the oil in the gearbox. The proper level should be between $\frac{1}{2}$ and $\frac{2}{3}$ full. Use 90 wt. or 140 wt. gear oil. Make sure the breather cap is clear and tight in the gearbox.

³ See chapter 4 - Maintenance.

⁴ See chapter 7 - Pre-delivery Checklist.

Check all hardware for tightness, especially the bolts holding the 3 point hitch⁵.

Grease the cross and bearings and the telescopic tubes of the driveline.

Ensure that the drive chains are well greased, both the tiller drive chain in the chain housing on the left side (**see fig. 16**) as well as the roller chain which drives the hopper on the right side of the machine. Both drive chains are supplied with an automatic chain tensioner.

Grease the rotor support (**see fig. 15**).

Make sure the hopper and seed cups are mounted correctly.

3.03 - Rear Tailgate Adjustment

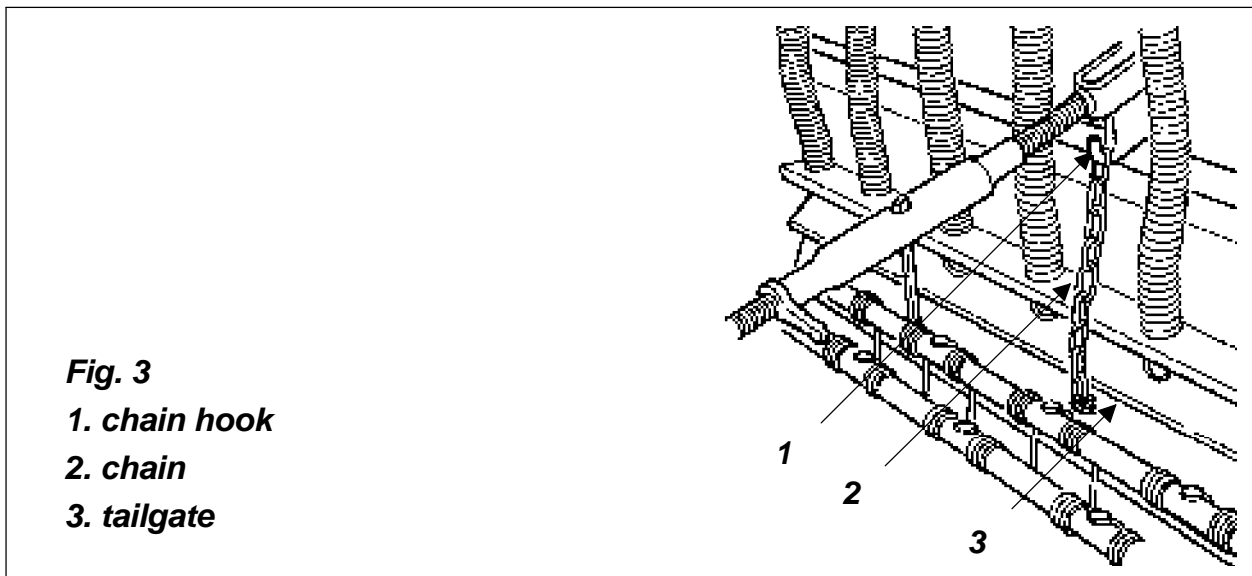

The rear tailgate, is especially important when using the tilling rotor in place of the straight blade aerating rotor. Its purpose is to improve the pulverisation of the soil as it is tilled. It can be adjusted in various positions with the chain. The closer the tailgate is to the rotor the more pulverised the soil will be. The rear tailgate also works as a shield to prevent dirt and other objects from being thrown (**see fig. 3**).

3.04 - Tickler Tine Adjustment

The Green-Rite comes with two rows of tickler tines mounted between the roller arms (**see fig. 4**). These tines work as a rake to help cover grass seed for ideal germination conditions. The tines are raised and lowered automatically as the roller follows the contour of the ground.

The roller arms have two set positions to increase or decrease the tickler tine pressure. When the tine holder is positioned in the lower hole the pressure is increased, the top

⁵ See table 4, page 32.

hole decreases the pressure. Always be sure both the right and the left side are in the same holes.

The tine holder bars can also be swivelled to increase or decrease the pressure of the tines. This also enables you to maintain a consistent pressure and angle as the tines wear. The bars can even be lifted completely up out of the way if the tickler tines are not to be used.

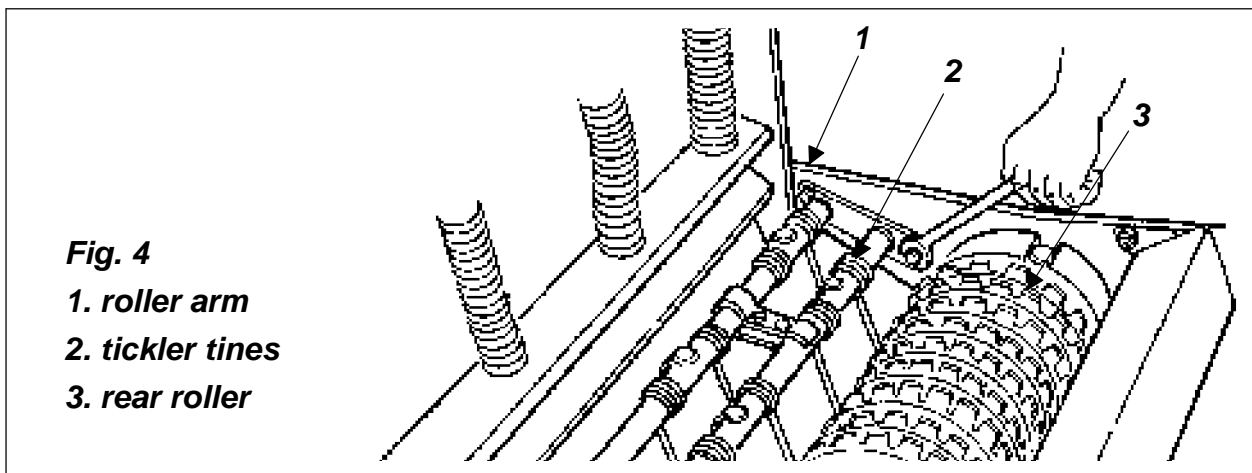

3.05 - Corrugated Roller Adjustment

The rear roller serves the following purposes:

1. controlling the working depth.
2. Levelling the ground after tilling.
3. Compacting which results in helping bury the material that is distributed. The roller rings help push seed into soil which greatly speeds up and improves germination.

A turnbuckle connected to the frame and to the roller support bar adjusts the working depth of the tines.

By shortening the turnbuckle, the corrugated roller raises thereby lowering the tines to a deeper depth (**see fig. 5**). Lengthen the turnbuckle lowers the roller which in turn raises the tines to a more shallow working depth

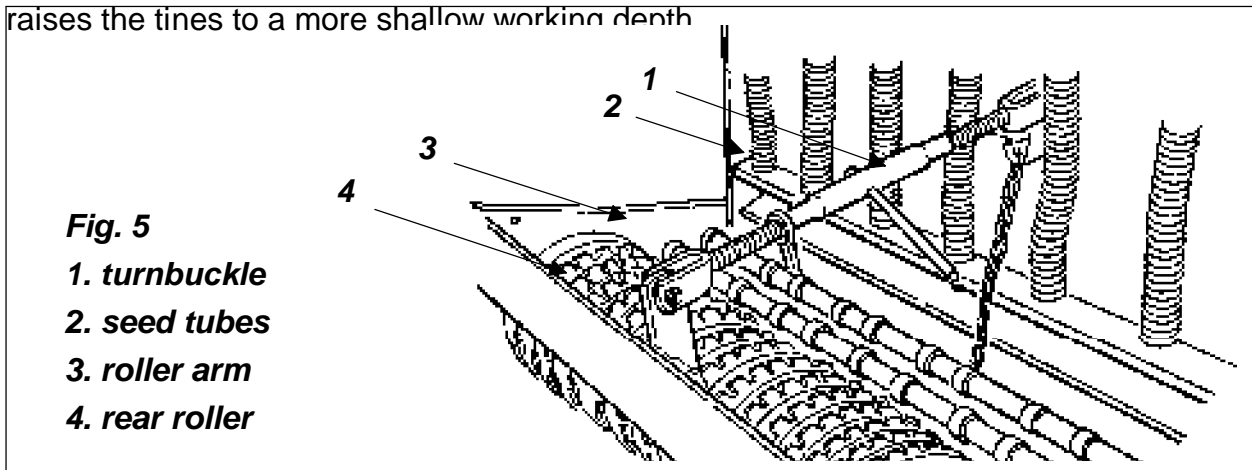

Under most conditions, the working depth for the aerating rotor needs to be only between 2 and 7 cm. ($\frac{3}{4}$ + - 1 $\frac{1}{2}$ +). The maximum obtainable depth is 18 or 22 cm. (7+ - 9+) depending on the Green-Rite model.

If the machine is using a tilling rotor the working depth needs to be deeper depending on what the operator needs. The maximum working depth is 18 or 22 cm. (7+ - 9+) depending on the Green-Rite model.

An adjustable roller-scraper bar is available upon request.



DANGER: stay clear of rotating driveline. Entanglement in rotating driveline can cause serious injury. Disengage PTO, engage parking brake or place transmission in 'Park', shut off the tractor and remove the key before working around hitch, attaching or detaching driveline, making adjustments, servicing or cleaning the machine.



DANGER: never trust the tractor hydraulics alone to support the machine. Never do any repairs or adjustments under the machine unless it is safely blocked.

3.06 - Front Roller Adjustment

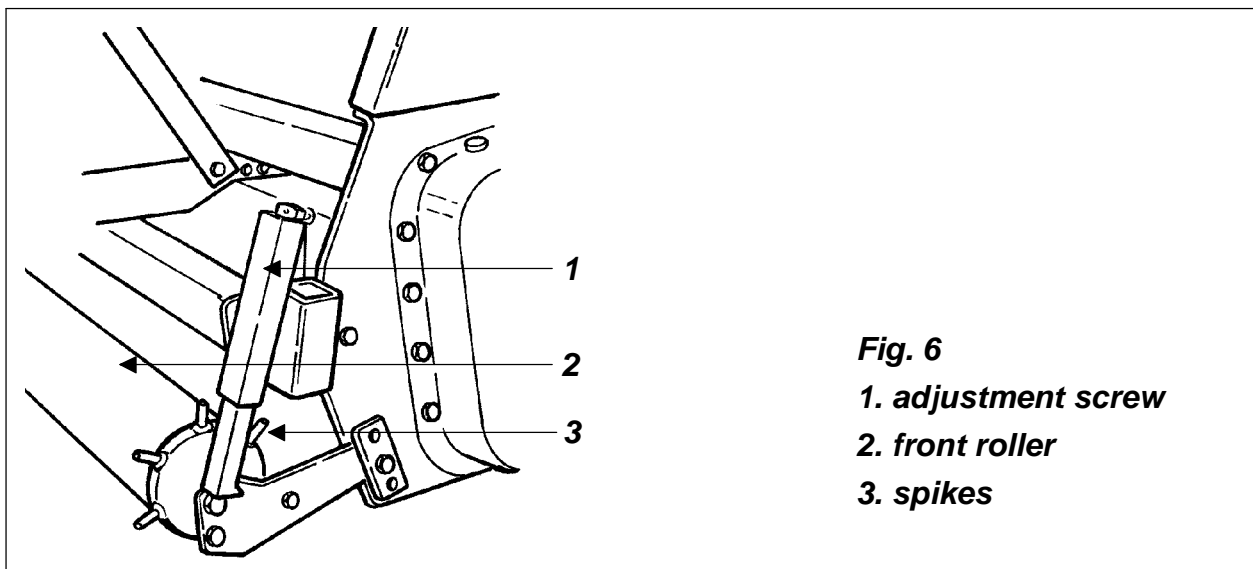

As an option, the Green-Rite can be supplied with a front roller. This option is very useful when the machine is attached to the tractor three point in the float position. This allows the machine to precisely follow the ground contour (see fig. 6).

The depth is controlled by turning the adjustment screws attached to each side of the machine. When using, be sure both adjustment screws are in the same position. The rear roller is then adjusted so the machine is working as level and parallel to the ground as possible. The spikes welded to the front roller ensure constant contact with the ground and prevents the roller from sliding along the ground and bulldozing.

3.07 - Front Wheels Adjustment

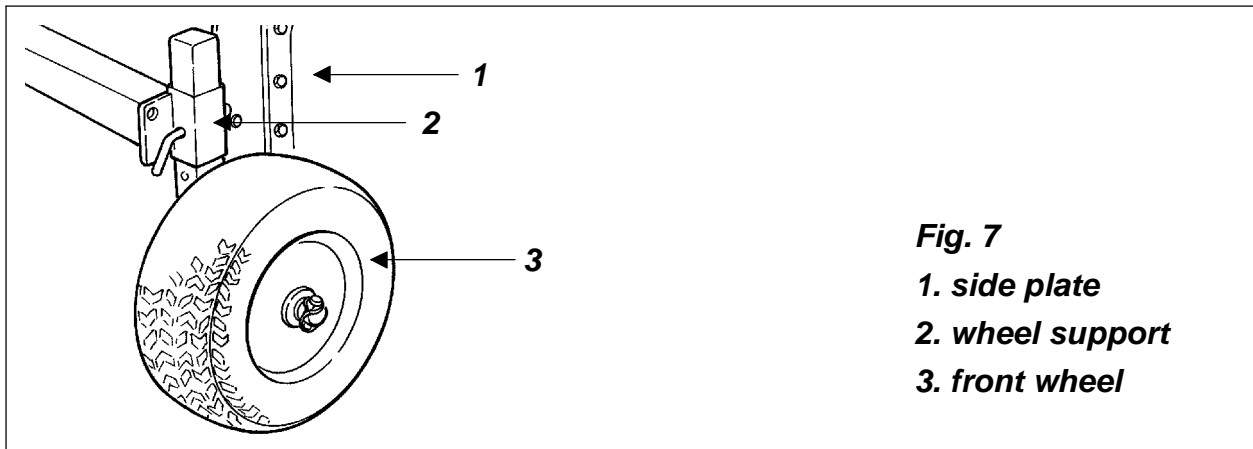

Fig. 7
 1. side plate
 2. wheel support
 3. front wheel

Upon request the machine can be adapted with two front depth control gauge wheels (see fig. 7) which are mounted on the side wheel support. These wheels have the same function as the front roller, allowing the machine to follow the ground contour. They also should be used with the tractor three point in the float position.

The depth is controlled by raising or lowering the wheels in the wheel supports attached to the side of the Green-Rite. When using, be sure both wheels are in the same position.

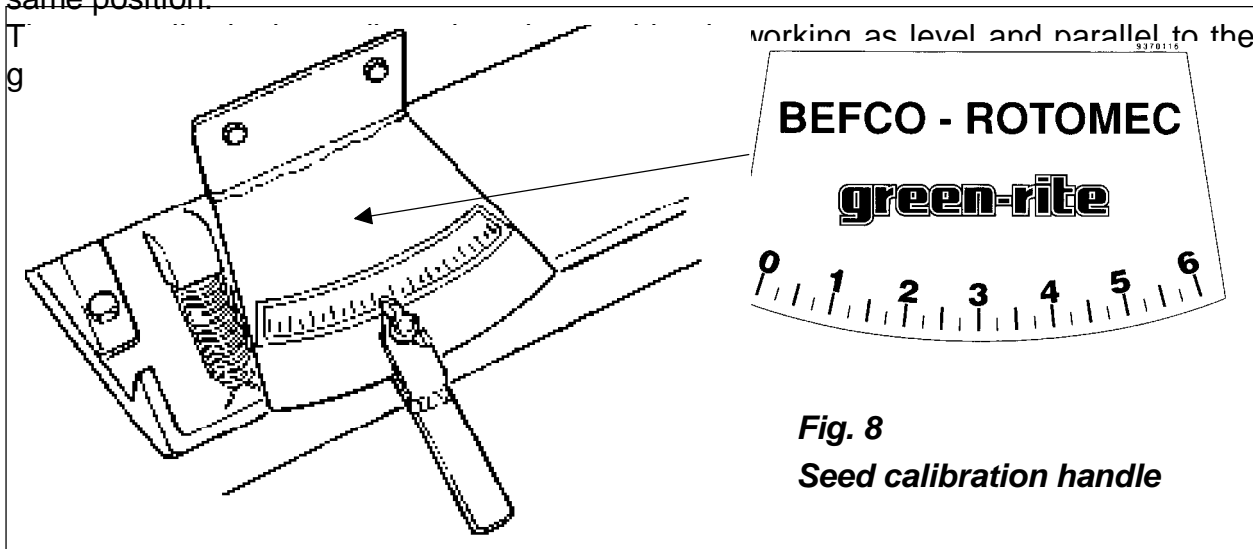

Fig. 8
 Seed calibration handle

The Green-Rite hopper capacities are for the GRT-145 of 150 litre (5.29 cu.ft.), for the GRT-165 of 170 litre (6 cu.ft.) and for the GRT-205 of 215 litre (7.6 cu.ft.). The hopper runs the entire width of the machine. It has a continuously rotating ground driven agitator to break-up clods and ensure free flow through the distribution system. On the bottom of the hopper are a certain number of rectangular slots (8, 9 or 11 depending on the width of the Green-Rite) to allow material passage. The **seed cups** mounted under the hopper, which are made entirely of non-corrosive material (nylon and fibreglass), contain an internal gear that rotates inside a housing. The amount of this gear inside the housing is regulated by a calibration handle on the rear of the hopper. The position of the handle, which has a scale of 0 to 6, determines the amount of seed collected (**see fig. 8**). The seed cups are a force feed system driven by the roller.

The material is held inside the groove of the gear until the groove rotates to the opening at the bottom of the hopper. This rotation is driven by the roller as it moves along the ground. When the handle is in position 0, the gear is completely outside the seed cup and no seed is collected, with the handle in position 6, the gear is totally inside the cup and distributes at its maximum potential (**see fig. 8**). A secondary regulation is the lever located on the side of each cup housing. This controls the position of the cleanout gate (top, middle, and bottom). Its position is determined by the size and shape of the material being dispersed (**see fig. 9**). The top position is for the smaller seeds, middle for the medium sized seed and bottom for larger seeds. Attached to the bottom of each cup is flexible tubing that the material flows through. As the material exits, it hits a split ring which divides the flow until it hits a splash pan and uniformly spreads over the entire working width of the Green-Rite.

The hopper is ground driven by the roller and automatic chain tensioners.

Although in essence a broadcast seed system, the Green-Rite ensures a precise calibrated flow. Being ground driven, the flow in the hopper is totally independent from the ground speed and is regulated solely by the regulation levers.

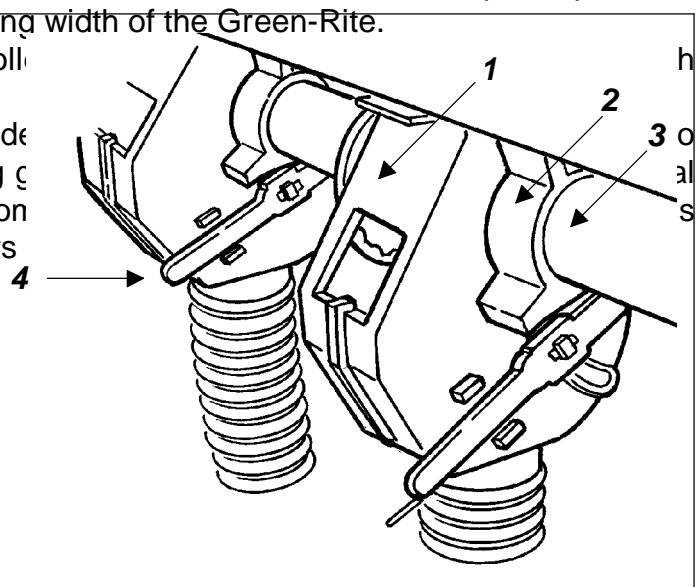

Fig. 9

- 1. seed cup**
- 2. gear support**
- 3. drive shaft bushing**
- 4. seed cup regulation lever**

3.09 - Seed (or Fertiliser) Hopper Calibration

There are two adjustments to be made to calibrate the Green-Rite hoppers:

1. the amount of gear inside the seed cup housing.
2. The position of the cleanout gate of each individual seed cup.

This system allows use of a wide variety of seed.

It is important to keep in mind that by being ground driven, the disbursement of the seed in the hopper is totally independent from the tractor PTO or the ground speed.

The output of seed differs greatly depending on their size, density, dampness, and shape. Other output factors depend on the conditions in which the machine is operating such as, in slick conditions where the roller may slip.

Table 1 lists the distribution rate in kilograms per hectare for various seed that may be used in the Green-Rite.

Keep in mind that the hopper and seed cup openings measure in volume and not in weight.

Due to the many variables, the distribution rate when using **table 1** is not always accurate.

TABLE 1 - APPROXIMATE AMOUNT OF SEED DISTRIBUTED IN KG/HA

Seed type	Calibration handle position											
	0,5	1	1,5	2	2,5	3	3,5	4	4,5	5	5,5	6
<i>Bentgrass</i>	38	80	100	139	175	204	226	258	281	300	325	343
<i>Kentucky bluegrass</i>	20	48	68	91	118	137	155	180	200	218	238	250
<i>Annual ryegrass</i>	21	60	88	118	157	186	216	255	285	313	353	382
<i>Perennial ryegrass</i>	30	72	103	135	177	210	240	283	315	346	388	420
<i>Fescue fine blade turf type</i>	18	48	70	93	122	143	167	198	220	241	270	293
<i>Fescue K-31</i>	5	34	58	80	106	128	150	177	197	218	231	235
<i>White clover</i>	60	138	197	255	333	392	449	528	586	644	722	781
<i>Red clover</i>	57	123	169	217	280	326	374	436	484	531	594	641
<i>Buffalo grass</i>	0	28	48	71	101	122	147	174	197	218	243	251
<i>Bermuda (hulled)</i>	43	97	132	168	216	251	288	336	370	407	455	491
<i>Western wheat grass</i>	8	27	40	54	72	85	100	118	131	146	162	177
<i>Crested wheat grass</i>	16	31	44	54	71	82	94	110	121	133	148	159
<i>Weeping love grass</i>	76	137	183	224	280	321	364	420	460	502	558	601
<i>Sand love grass</i>	60	115	156	209	250	290	330	385	426	466	520	560
<i>Alfalfa</i>	48	123	180	239	314	370	428	504	560	618	692	750
<i>Vetch</i>	49	108	157	195	252	297	339	396	440	484	542	586

Use **table 2 and 3** to determine if the rate you are getting is correct.

There are two ways of setting the calibration on your Green-Rite:

1. with the machine stopped and raised,
2. with the machine attached to the tractor and working.

To set the calibration with the machine stopped, do the following:

1. support the machine securely, but in a way to allow the roller to turn freely.
2. Fill the hopper with the seed or fertiliser you intend to spread.
3. Make sure the seed cups are not plugged with leaves, grass or other obstacles.
4. Remove the seed tubes from the lower bar to allow the seed to fall so it may be collected easily.
5. Move the calibration handle located in the rear of the hopper to a position between 1 and 6 (**see fig. 8**).
6. Turn the roller a precise number of complete turns (a minimum of 20-30, the greater the number the more accurate the measurement).
7. Gather up and weigh all the material distributed. Divide this by the number of turns the roller made. This will give the amount of material dispersed per turn of the roller.
8. Knowing that each roller revolution, in the GRT-145 model, corresponds to a surface area of 1.29 square meters, that 77.5 turns of a roller is equal to 100 square meters, and that 7751 revolutions is equal to 1 hectare, multiplying the quantity obtained with each revolution by 7751 will give you the kilograms of material being distributed per hectare (**see table 2**; 1 roller revolution covers 13.88 square feet and 72 revolutions equal to 1,000 square feet, thus 3,137 roller revolutions equal to 1 acre. Multiplying the quantity obtained with each revolution by 3,137 will give you the pounds of seed being spread per acre).

- If the results do not correspond to the desired amount which needs to be distributed, adjust the calibration handle accordingly.

TABLE 2 - WORKING SURFACE

GR-145	GR-165	GR-205
1 revolution=1,29 m ² (13.88 sq.ft.)	1 revolution=1,64 m ² (17.62 sq.ft.)	1 revolution=1,82 m ² (19.59 sq.ft.)
3137 revolutions = 1 acre	2773 revolutions = 1 acre	2224 revolutions = 1 acre
7751 revolutions = 1 hectare	6850 revolutions = 1 hectare	5494 revolutions = 1 hectare
77,5 revolutions = 100 m ²	68,5 revolutions = 100 m ²	54,9 revolutions = 100 m ²
72 revolutions = 1000 sq.ft.	64 revolutions = 1000 sq.ft.	51 revolutions = 1000 sq.ft.

To calibrate the Green-Rite while it is working, do the following:

- measure out a predetermined distance on the ground (for example 50 linear meters), keeping in mind that the further the distance, the more precise the measurement.
- Fill the hopper with the seed you intend to spread.
- Make sure the seed cups are not plugged with leaves, grass or other obstacles.
- Remove the seed tubes from the lower bar and attach bags to the ends to allow the material to be collected.
- Move the calibration handle located in the rear of the hopper to a position between 1 and 6.
- Drive the tractor forward pulling the machine along the predetermined distance. It is important for the roller to remain on the ground at all times and to roll continuously.
- Collect all material distributed and weigh.
- Using **table 3** determine the amount of material distributed. **Example: if the distance travelled is 50 meters and ½ kg. of material is collected, then 69 kg. per hectare of material is being distributed.**
- If the results do not correspond to the desired amount which needs to be distributed, adjust the calibration handle accordingly.

TABLE 3 - AMOUNT OF MATERIAL DISTRIBUTED IN KG/HA

KG. collected all seed cups	Distance travelled in meters									
	50	100	150	200	250	300	350	400	450	500
0,05	6,9	3,5	2,3	1,7	1,4	1,1	0,9	0,8	0,7	0,6
0,25	34,4	17,2	11,5	8,6	6,9	5,7	4,9	4,3	3,8	3,4
0,5	69	34,5	22,9	17,2	13,8	11,5	9,8	8,6	7,6	6,9
1	138	69	46	34,5	27,6	22,9	19,7	17,2	15,3	13,8
1,5	206,9	103,4	69	51,7	41,4	34,5	29,6	25,9	23	20,7
2	275,9	137,9	92	69	55,2	46	39,4	34,5	30,7	27,6
2,5	344,8	172,4	114,9	86,2	69	57,5	49,3	43,1	38,3	34,5
3	413,8	206,9	137,9	103,4	82,8	69	59,1	51,7	46	41,4
3,5	482,8	241,4	160,9	120,7	96,6	80,5	69	60,3	53,6	48,3
4	551,7	275,9	183,9	137,9	110,3	92	78,8	69	61,3	55,2
4,5	620,7	310,3	206,9	155,2	124,1	103,4	88,7	77,6	69	62,1
5	689,7	344,8	229,9	172,4	137,9	114,9	98,5	86,2	76,6	69
5,5	758,6	379,3	252,9	189,7	151,7	126,4	108,4	94,8	84,3	75,9
6	827,6	413,8	275,9	206,9	165,5	137,9	118,2	103,4	92	82,8
6,5	896,6	448,3	298,9	224,1	179,3	149,4	128,1	112,1	99,6	89,7
7	965,5	482,8	321,8	241,4	193,1	160,9	137,9	120,7	107,3	96,6
7,5	1.034,5	517,2	344,8	258,6	206,9	172,4	147,8	129,3	114,9	103,4
8	1.103,4	551,7	367,8	275,9	220,7	183,9	157,6	137,9	122,6	110,3
8,5	1.172,4	586,2	390,8	293,1	234,5	195,4	167,5	146,6	130,3	117,2
9	1.241,4	620,7	413,8	310,3	248,3	206,9	177,3	155,2	137,9	124,1
9,5	1.310,3	655,2	436,8	327,6	262,1	218,4	187,2	163,8	145,6	131

3.10 - Driveline

Carefully read and file away the driveline operator's manual supplied by the manufacturer. The following does not substitute for the information found in the driveline manual.



DANGER: only use the original driveline supplied with this machine and always with the safety shielding.

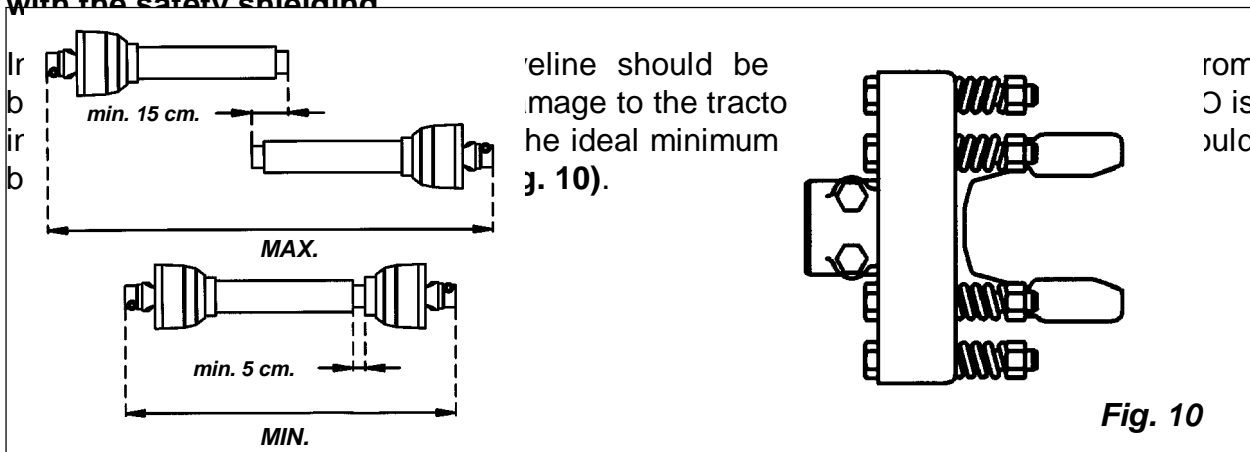

Fig. 10

If it is determined that the driveline is too long. Follow these procedures to adjust the length.

1. Separate the two driveline halves. Connect one half to the tractor PTO and the other half to the implement.
2. Raise and lower the implement with the 3 point hitch to find the position where the driveline is shortest. Hold the half shafts side by side and mark the desired length on the outer female tube guard leaving a 5 cm. (2+) gap between the end of the guard tube and bell guard.
3. Cut off both guard tubes the same amount as marked in step 2.
4. Shorten both drive tubes the same amount as the guard tubes.
5. De-burr and clean filings from drive tubes and apply grease to outside of inner telescoping tube.

Reassemble the driveline halves and connect to tractor and implement. Raise and lower machine again to be sure driveline does not bottom out in the shortest position and has a minimum overlap of 15 cm. (6+) in the longest position.

3.11 - Safety Slip Clutch

Your Green-Rite is supplied with a safety slip clutch, it is important to ensure that it is working properly. The slip clutch delivered with your machine is set at a specific torque for normal working conditions (**see fig. 10**).

If while working, the clutch slips frequently, the spring nuts need to be tightened $\frac{1}{2}$ turn. Check the clutch after 200-250 m. (600-800 ft.), if necessary repeat the operation. If after tightening the nuts down and the clutch continues to slip, the discs will have to be replaced.

Follow the instructions in reverse, if while working under normal conditions the clutch does not slip at all.

3.12 - Pre-Operational Check

Check each of the following, carefully, prior to engaging machine:

1. the rotor support has been greased and the drive chain is lubricated.
2. The oil in gearbox is between $\frac{1}{2}$ and $\frac{2}{3}$ full.
3. The driveline cross & bearings has been greased.
4. No wrappings or foreign objects are on the machine or driveline.

5. The blades are properly installed and the blade bolts and nuts properly torqued⁶.
6. All hardware is tight⁷.
7. Check the tractor to ensure correct direction of PTO and rpm speed.
8. Ensure all safety shields and guards are in their place and tightly attached.
9. No people or animals are in the work area.
10. When working, make sure the Green-Rite has its full weight riding on the roller. The front of the machine should be held upward at a slight angle by the tractor arms.



DANGER: always stay clear of rotating driveline and blades when the PTO is engaged.



WARNING: disengage the PTO, apply the parking brake, shut off the engine and remove the key before attaching or removing the driveline, or performing any maintenance or adjustments on the machine.

3.13 - Attaching to the Tractor

Unit may be used on tractors equipped with a standard rear PTO with horsepower in the correct power range⁸ and cat. 1 three point hitch.

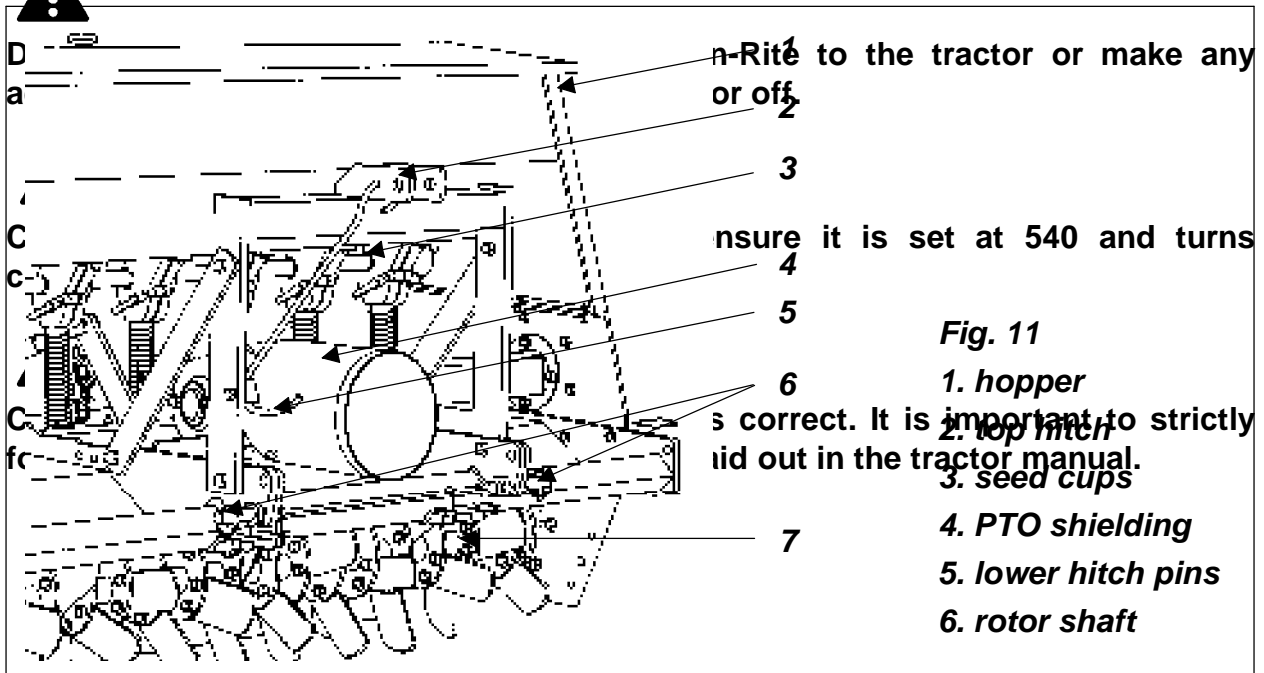

Fig. 11

1. hopper
2. top hitch
3. seed cups
4. PTO shielding
5. lower hitch pins
6. rotor shaft

⁶ See table 4, page 32.
⁷ See table 4, page 32.
⁸ See table 5, page 32.

To attach the implement to the tractor do the following:

Back the tractor up to the Green-Rite in order to slip the tractor hitch arms over the hitch pins bolted to the frame. **Turn off the tractor engine.**

The lower hitch pins (**see fig. 11**) may be put in either of 2 positions (upper or lower) depending on the tractor. Optional hitch blocks are available for use on tractors with non standard three point hitches. Secure the two arms with the lynch pins. Tighten the tractor arms side movement with either the sway chains or blocks to limit side swing to 2+3+. Connect the top link, locking it in place with the top hitch pin. Adjust it so the Green-Rite is as near parallel to the ground as possible. A 1 to 2 degree rearward tilt is acceptable (**see fig. 12**).

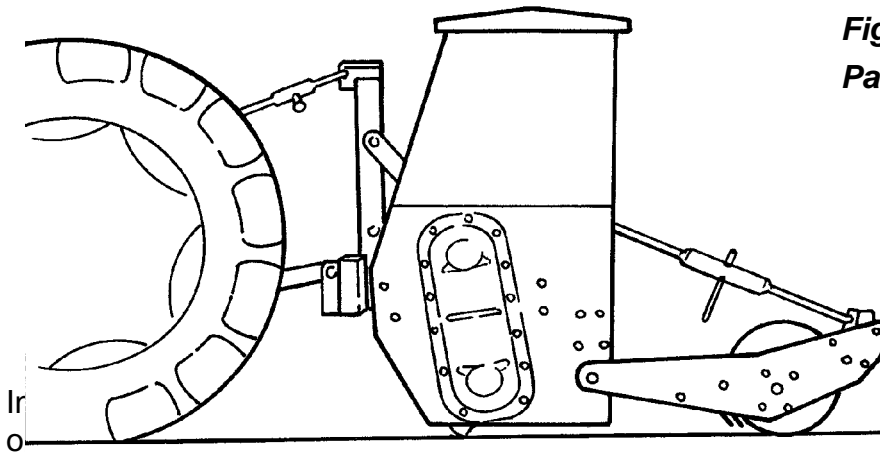

Fig. 12
Parallel to the ground

ne and the
th either the
locking pin or bolt and nut. Connect the driveline chains to the tractor and to the machine to prevent the protective shielding from rotating during operation. If it was necessary to remove the PTO protection to do any of the above operations, do not forget to replace it.

After use, if the machine is not supplied with front gauge wheels or a front roller, the machine should be lowered and allowed to rest on the stand which is supplied with the machine (see fig. 13).

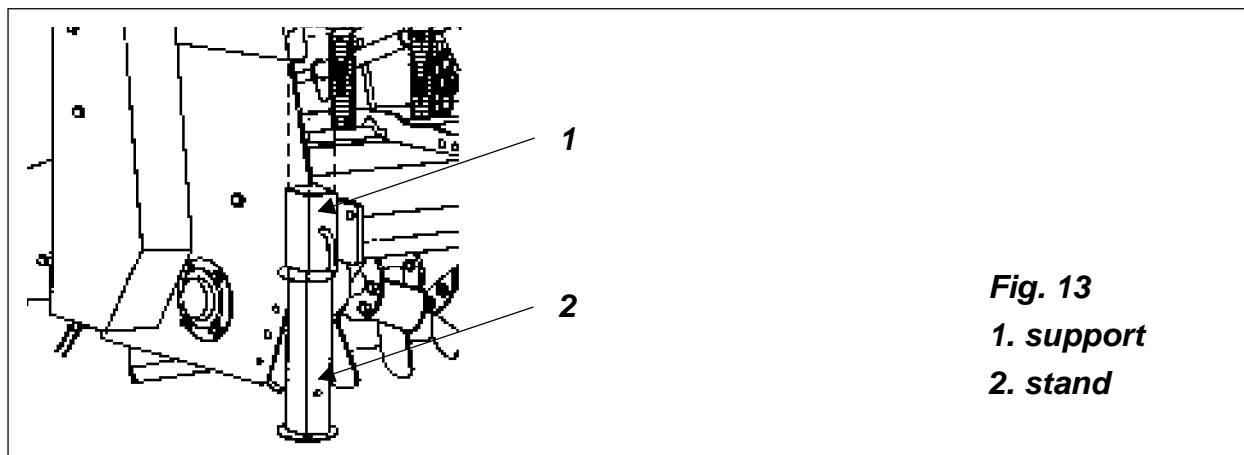

Fig. 13
1. support
2. stand

3.14 - Start Up



DANGER: never allow anyone around the Green-Rite when it is in operation. Never engage the tractor PTO before the tines are about to touch the ground.



DANGER: operate the implement only at the speed and direction of rotation indicated on the machine. Serious damage can result if this is not followed.



CAUTION: before starting work, clear the area of any obstacles or foreign objects.

The Green-Rite is set up to be used on tractors with a PTO of 540 rpm.

With the engine in neutral and tractor rpm low, engage the PTO and very slowly bring the tractor rpm up to $\frac{3}{4}$ its normal working speed. Lower the machine to the ground and increase the rpm until a PTO speed of 540 is reached. Never operate over 540 rpm.

When using the maximum rated horsepower tractors, it is important to feather in the PTO. Sudden jolts of high power can cause damage to the driveline or gearbox⁹.

⁹ See table 5, page 32.

Start out with the tractor in the lowest gear, increase gears slowly if necessary.

Avoid working in reverse.

Before beginning work always remember that the operator is responsible for:

1. safe and correct operation of the tractor and Green-Rite.
2. Learning and following precise, safe operating procedures for both the tractor and the Green-Rite.
3. Ensuring all maintenance and lubrication has been performed on the Green-Rite.
4. Having read and understood all safety aspects for the green-rite in the operator's manual.
5. Having read and understood all safety decals on the green-rite.
6. Checking the condition of the blades. Worn or damaged blades should be changed before starting.
7. Checking to ensure that the cutting edge is the leading edge of the blade.
8. Checking that there are no wires, weeds, grasses or other objects wrapped around the rotor.
9. Checking to see if front weights need to be added to the tractor in order to maintain balance.
10. Checking the tractor tires for the proper pressure in accordance to the tractor operator's manual.
11. Checking that all shielding is on the machine and securely in place.
12. Making sure the proper attire is worn. Avoiding loose fitting clothing which can become entangled. Wearing sturdy, tough-soled work shoes and protective equipment for eyes, hands, ears and head. Never operate tractor or implements in bare feet, sandals or sneakers.
13. Checking area for stones, branches and other debris that might be thrown.
14. Ensuring proper lighting is available, sunlight or good artificial lighting.



DANGER: never use the machine without first assuring all protective devices are properly installed. Never forget that due to their high blade tip speed, blades can be thrown great distances and cause injury or death to bystanders.



CAUTION: for emergency reasons, learn how to stop the tractor and implement quickly. On the Green-Rite, always disengage the PTO, lock parking brake, stop engine and allow the blades to come to a complete stop before dismounting the tractor.

3.15 - Test Run

After the first 50-100 meters it is important to stop, raise the machine and disengage the PTO just as the blades are coming out of the ground. Lower the machine, turn off the tractor engine and remove the key.

At this point make sure the Green-Rite is performing correctly. Check for loose bolts or nuts, paying particular attention to the blade bolts.

3.16 - Working Depth

When using the **aerating rotor** which comes standard with the machine, normally a depth of approximately 2 to 7 cm. ($\frac{3}{4}$ +) is all that is desired. This is enough to loosen the soil without tearing up existing grass. It is very important to check the depth prior to the corrugated roller going over where the blades have cut into the ground.

With the optional **tilling rotor** the depth of cut is determined largely by the condition of the ground. When working hard or previously unworked ground, set depth at no more than 5-7 cm. (2+3+). Greater depth may require a second pass. The maximum tilling depth is 18 or 22 cm. (7+or 9+) depending on the Green-Rite model.

NOTE: excessive vibration or jumping of the machine is an indication that the machine is working too deep for conditions, such as in hard, parched or compacted soil and should be adjusted accordingly.

3.17 - Working Speed

Ground speed is determined by the soil condition, depth of cut, and tractor power. Simple experimentation will soon determine the best speed for the desired results, usually 2 to 3 km/h (1 to 2 mph).

When using the **aerating rotor** the blades need to make a continuous slice, if there is some skipping you need to slow down the ground speed.

A slow ground speed with the **tilling rotor** will result in a finer soil, as a faster ground speed will render the opposite. The rear shield, besides being a safety device, will help in producing a finer worked soil. Test results show that a raised shield will leave a coarser finished surface.

3.18 - Headland Procedure

When the headland is reached, it is important that the following be observed:

1. raise the machine from the ground and as soon as the blades leave the ground, disengage the tractor PTO.
2. Turn the tractor facing the new desired direction of travel.
3. Begin working again¹⁰.

¹⁰ See paragraph 3.12 - Pre-Operational Check.

NOTE: best practice dictates that the machine be lifted no more than just enough to clear the ground. Running the machine at an extreme angle could damage the PTO.

3.19 - Working Limitations

When using the tilling rotor, if the blades will not penetrate the ground easily or the machine jumps and vibrates excessively, conditions may be too dry, tough or compacted. (Also make sure that the blades are properly installed¹¹ with the proper scroll and the bolts properly torqued¹²).

Under these extreme conditions it may be wise not to use the tiller as a primary tillage tool. Run over the ground with a disc or plow prior to tilling.

3.20 - Uneven Terrain



DANGER: be careful when operating tractor and machine over uneven ground to avoid rollover. In extremely uneven terrain rear wheel weights, front tractor weights and/or tire ballast should be used to improve stability.

When working over uneven terrain, observe the type of terrain and develop a safe travel pattern. Whenever traction or stability is doubtful, first test drive over the terrain with the PTO disengaged.

Operate the machine up and down steep slopes, not across slopes, to prevent the tractor from tipping. Avoid sudden stops and starts and slow down before changing directions on a slope.

Pass diagonally through sharp dips and avoid sharp drops to prevent hanging up the tractor and machine.

Slow down on sharp turns and slopes to prevent tipping or loss of control.

Avoid tipping the machine while working. Watch for holes, roots or other hidden objects. Do not work near the edge of a gully, ditch or stream bank.

3.21 - Transporting



CAUTION: All operations of transport are to be done without the Green-Rite working and respecting all local traffic rules and regulations.

¹¹ See paragraph 4.04 - Blade Maintenance.

¹² See table 4, page 32.

During transport or when the machine is lifted from the ground, it is advisable to adjust the tractor lift arms in order to be able to raise the machine 35-40 cm. (14%±6+) from the ground (**see fig. 14**).

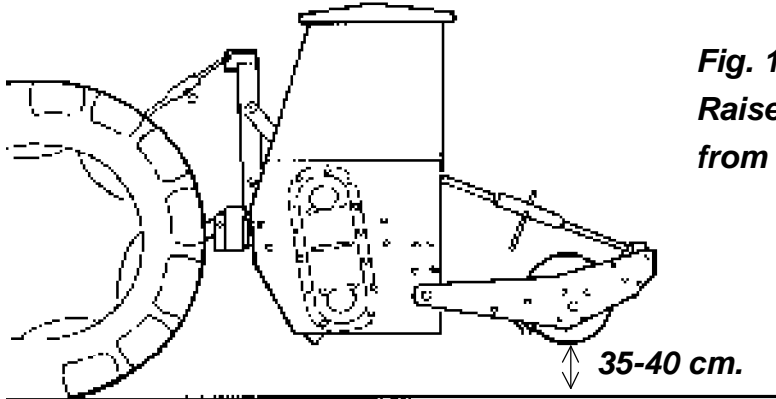

Fig. 14
Raise the machine 35-40 cm.
from the ground during transport.

4 - MAINTENANCE



DANGER: stop engine, lock parking brake and remove key before performing any service or maintenance.

Never rely on the tractor lift system. Install blocks or stands under the machine to prevent it from falling. Always use personal protection devices, such as glasses or gloves when performing maintenance.

Keep fingers out of slots to prevent injury.

4.01 - Maintenance Safety



1. Good maintenance is your responsibility.
2. Keep service area clean and dry. Be sure electrical outlets and tools are properly grounded. Use adequate light for the job at hand.
3. Make sure there is plenty of ventilation. Never operate the engine of the towing vehicle in a closed building. The exhaust fumes may cause asphyxiation.
4. Make no repair or adjustments with the tractor engine running. Before working on the machine, disengage the PTO, shut off the engine, set the brakes, and remove the ignition key.
5. Be certain all moving parts on attachment have come to a complete stop before attempting to perform maintenance.
6. Never work under equipment unless it is blocked securely.
7. Never trust the tractor hydraulics alone to support the machine. Before repairing or adjusting, the machine should be lowered and allowed to rest on the supplied stand.
8. Always use personal protection devices such as eye, hand and hearing protectors, when performing any service or maintenance.
9. Frequently check blades. They should be sharp, free of nicks and cracks and securely fastened.
10. Periodically tighten all bolts, nuts and screws and check that all cotter pins are properly installed to ensure unit is in a safe condition.
11. When completing a maintenance or service function, make sure all safety shields and devices are installed before placing unit in service.
12. Do not attempt to mount a tire unless you have the proper equipment and experience to do the job.
13. Inflating or servicing tires can be dangerous. Whenever possible, trained personnel should be called to service and/or mount tires.
14. After servicing, be sure all tools, parts and service equipment are removed.

15. Never replace hex bolts with less than grade five bolts unless otherwise specified, i.e. shear bolts¹³.
16. When the machine is not hooked to the tractor, the driveline must be supported by the storage hook to the top link.
17. Where replacement parts are necessary for periodic maintenance and servicing, genuine replacement parts must be used to restore your equipment to original specifications. The company will not claim responsibility for use of unapproved parts and/or accessories and other damages as a result of their use.
18. Unauthorised modifications to the machine may impair the function and/or safety of the machine and reduce its life. If equipment has been altered in any way from original design, the manufacturer does not accept any liability for injury or warranty.

4.02 - Service

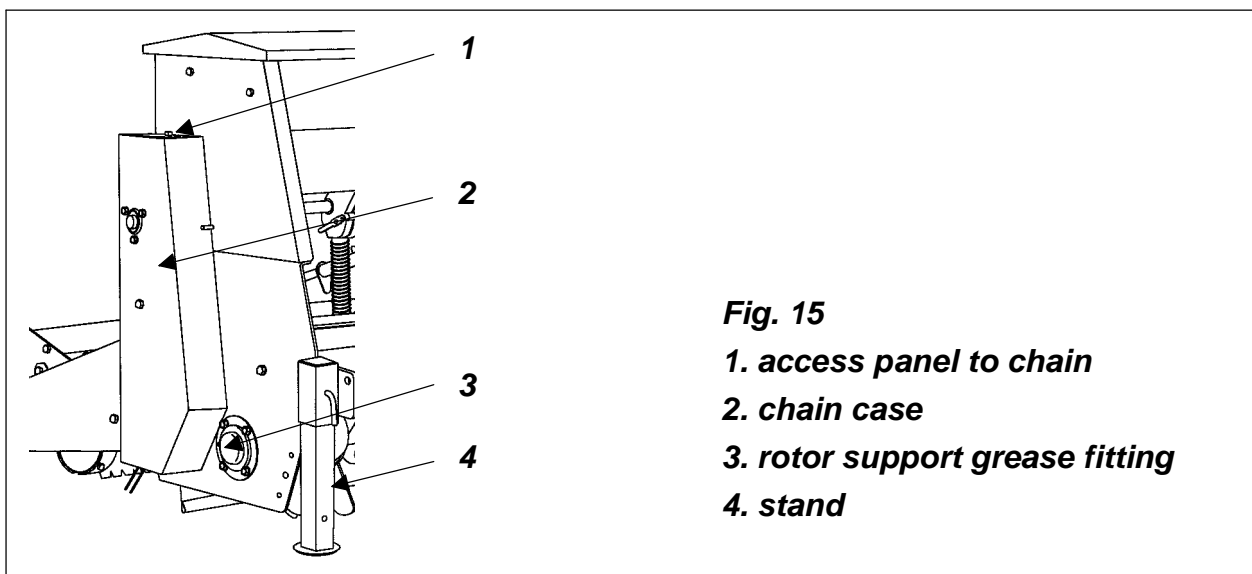

The following illustrations show lubrication points. The frequency of lubrication given is based on normal operating conditions. Severe or unusual conditions may require more frequent lubrication.

Use a good quality SAE multipurpose type grease for all locations shown. Be sure to clean fittings thoroughly before using grease gun. Immediately replace any broken or missing fittings.

Use 90 wt. or 140 wt. gear oil in gearbox.

Hourly or whenever an obstacle is hit:

1. check machine condition, particularly the blades.
2. Replace any damaged or worn blades.
3. Remove any wrapping (stalks, weeds, trash, etc.) from rotor, especially from around bearing supports on the rotor ends.

¹³ Refer to table 4 - Torque Specifications, for head identification marking.

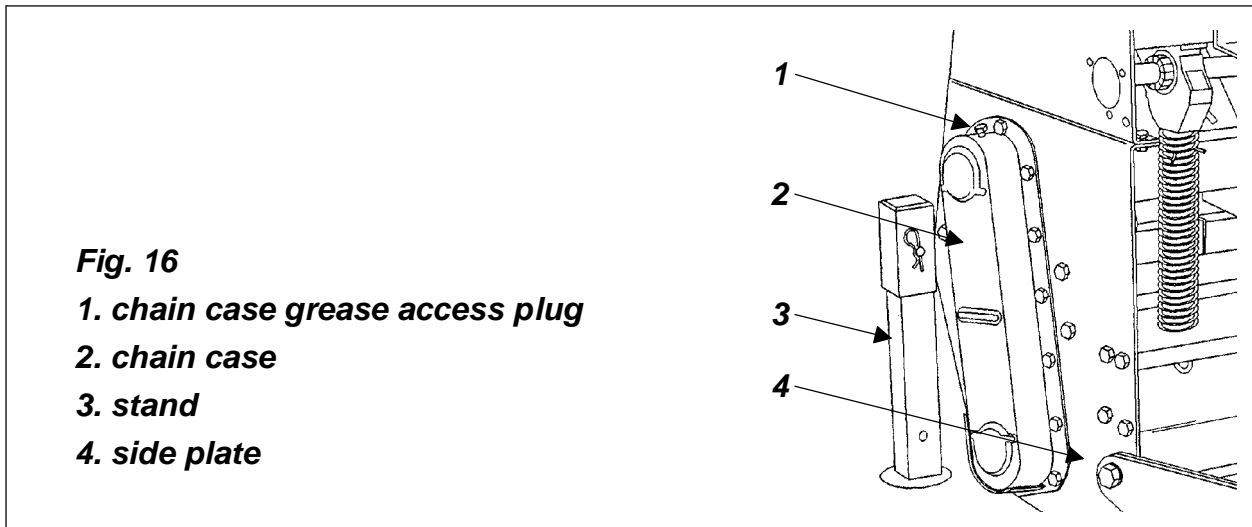
**Every 8 hours:**

1. **grease the rotor support (see fig. 15) and the roller support (see fig. 17), the driveline cross & bearings and telescopic tubes.** Apply two or three shots of grease to the driveline cross and bearings and the telescoping shafts. Apply the same amount to the rotor and roller bearings. See the driveline manufacturer operator's manual for further information on the driveline.
2. **Gearbox oil level:** check gearbox oil level, it should be between $\frac{1}{2}$ and $\frac{2}{3}$ full. If needed add either SAE 90 wt. or SAE 140 wt. gear oil.

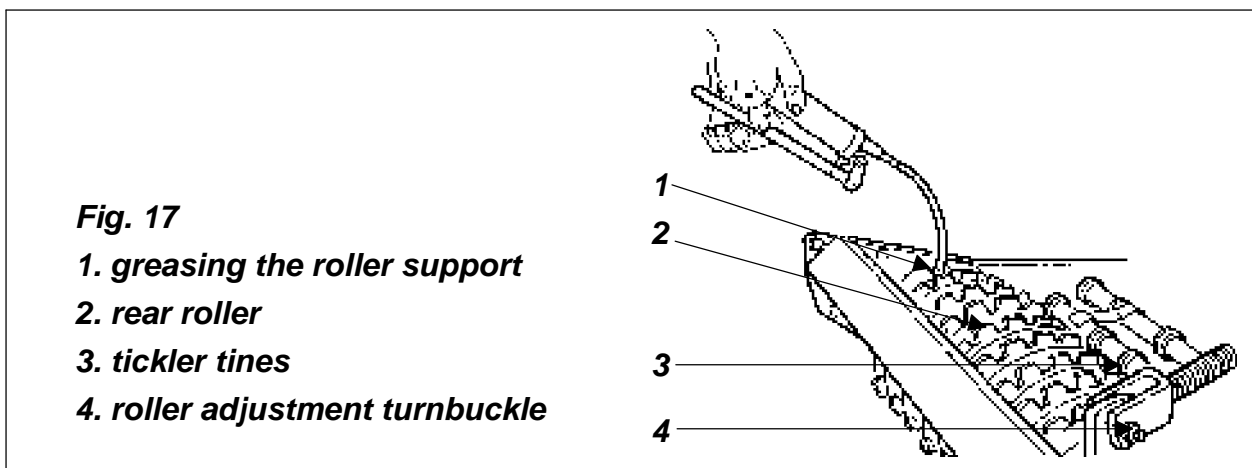

Whenever the hopper is used for fertiliser spreading it is extremely important to carefully clean out the hopper and wash the machine with hot water. Do not forget that fertiliser is highly corrosive and should be not left in the hopper any longer than necessary.

Every 25 hours:

hardware tightness: vibration can loosen bolts¹⁴. Check tightness of the hardware periodically¹⁵.

Every 50 hours:

check the blades for excessive wear or damage. Be sure the rotor turns freely. Look at all the drive chains and make sure they are well lubricated (**see fig. 15 and 16**).

After the first 200 hours:

remove the chain case cover (being sure not to damage the gasket), clean the chain sprockets with kerosene, replace the sprockets and reassemble using fresh GP grease (approximately) 1 kg (2.2 lb.).

4.03 - Changing Rotors

The Green-Rite can use two different types of blades; a straight aerating blade and a standard tilling blade. Each of the two types requires a different rotor.

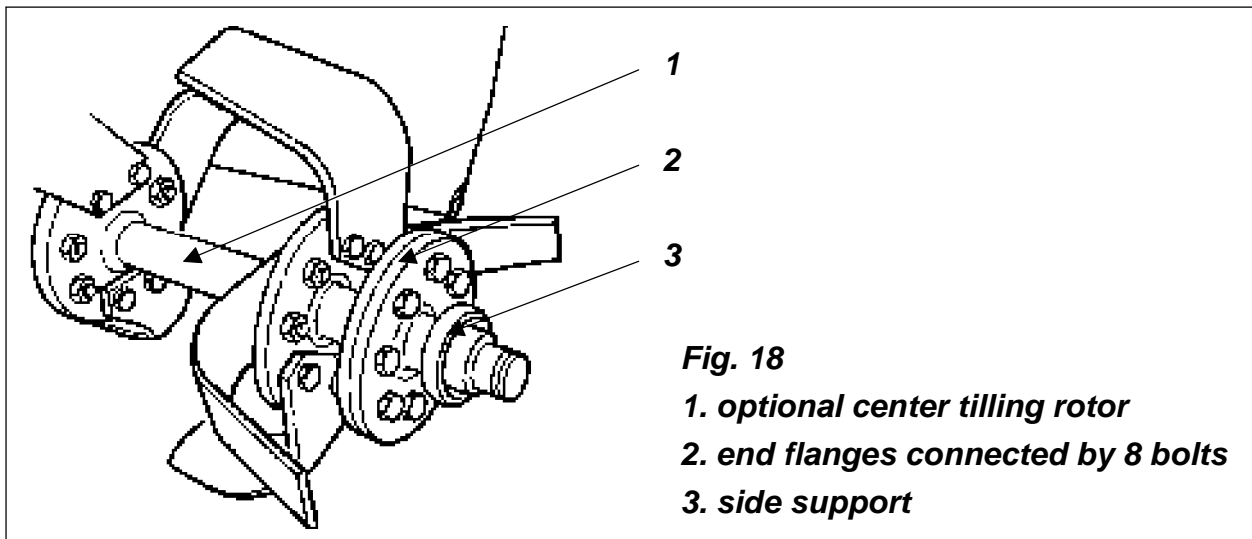

Fig. 18
1. optional center tilling rotor
2. end flanges connected by 8 bolts
3. side support

It is always recommended to purchase the machine with both rotors in order to get the most use out of the Green-Rite. Changing the rotor is a very simple operation. Both types consist of two side supports and a the centre flanged rotor. The centre flanged rotor is either an aerating rotor or a tilling rotor. The two side supports (one left and one right) are the same for whichever centre rotor is being used. The centre rotor is bolted to the two side supports by 16 bolts (8 per side) (**see fig. 18**).

To change from one rotor to the other, unbolt these 16 bolts, remove the centre rotor and bolt the other rotor in place. An operation which is performed in just a few minutes but gives great flexibility to the machine.

¹⁴ See table 4, page 32.

¹⁵ See table 4, page 32.

4.04 - Blade Maintenance



WARNING: avoid possible injury. Wear proper eye and hand protection when servicing machine blades.

It is important to change blades after **they have worn down 2.5 - 3 cm. (1-1¼")** from their original length. When replacing blades, it is best to replace them one at a time to maintain the original scroll pattern. If, however, it becomes necessary to remove them all, **it is essential to maintain the scroll pattern of the blades (see fig. 19)**. To do this, remove one blade and immediately replace it with a new one. Be sure the bolt head (see #3, fig. 20) is touching the blade #4, while the washer #5 and nut #6 contact the flange. Sometimes a locknut is used instead of a lockwasher and nut. Proceed until all blades needed to be changed are changed.

After putting on the new blades, tighten the nuts to their proper torque specifications.

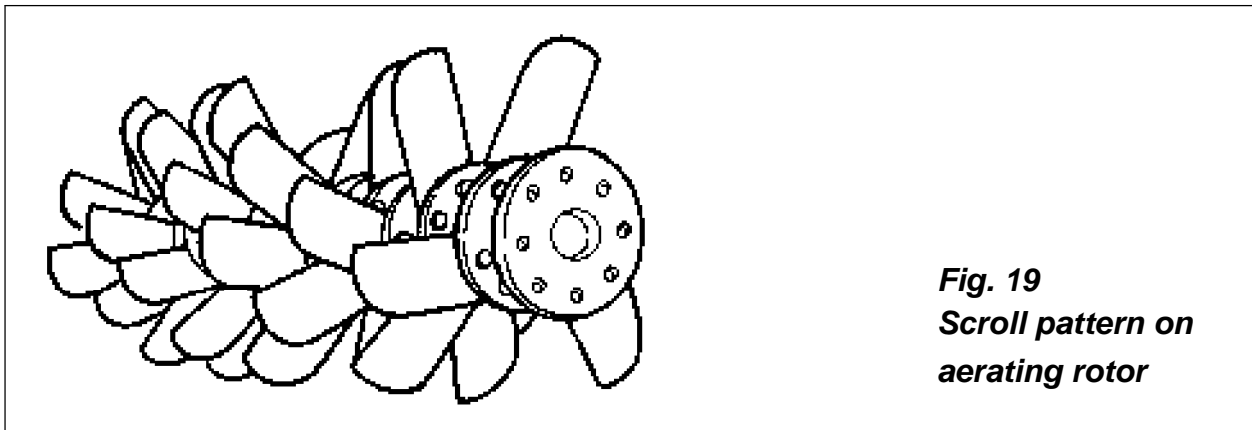

Fig. 19
Scroll pattern on
aerating rotor

After putting on the new blades, tighten the nuts to their proper torque specifications.

To determine if a blade is right or left, do the following:

1. hold the blade in the palm of the hand with the bend pointing upward.
2. If the cutting edge points toward the right then the blade is right-handed.
3. The cutting edge pointing to the left indicates a left-handed blade.

NOTE: on the aerating rotor, all blades are the same. It is not necessary to determine a left or right.



DANGER: proper torque must be used when tightening the blade retaining bolt. If these safety precautions are not followed, the blade could come off during operation and be thrown tens of meters from the machine.

GR-205	40-70	205	226	675	215	10	40	231	12-14	220	ASAE 6 th cat.
--------	-------	-----	-----	-----	-----	----	----	-----	-------	-----	---------------------------

5 - REPAIR PROCEDURES



CAUTION: all repair procedures must be done by authorised dealerships. It is not recommended that untrained individuals perform any repair work. The following operations are detailed for qualified personnel only.

5.01 - Gearbox

To remove the gearbox from the side shift frame proceed as follows:

1. remove the front and the rear bolts holding the gearbox to the side shift frame.
2. Slide the side shift frame over until the gearbox is off the hexagonal shaft.
3. Whenever the bearings are removed from the gearbox, all **oil seals should be replaced** to assure no leaks when the box is reassembled.
4. To avoid damage to components, bearings should always be removed with bearing pullers and pressed in when being replaced.
5. When reassembling the gearbox, ensure that there is a precise match between ring and pinion gears.

5.02 - Chain Case

To remove the chain do the following:

1. unbolt chain case cover.
2. Remove the chain case cover taking care not to damage the gasket.
3. Release the automatic chain tensioner spring.
4. Remove the two snap rings holding the chain sprockets
5. Slip off both chain sprockets at the same time.

To replace the chain follow the procedure in reverse order, ensuring the gasket is not damaged. If damaged it must be changed.

5.03 - Removing the Rotor

To remove the rotor proceed as follows (**see fig. 18**):

1. unbolt the 16 bolts holding the centre rotor to the right and left side supports.
2. Remove the rotor.

When replacing the rotor, do not force and take care not to damage the bearings and seals in the supports.

5.04 - Suggested Spare Parts

It is suggested that the following spare parts be kept on hand at all times to prevent a minor problem from delaying work:

Description	Quantity
Aerating blades	6
Tilling Blade - Right	5
Tilling Blade - Left	5
Blade bolts	10
Nuts	10
Chains	1 set

5.05 - Storage

After seasonal use it is important to perform the following for prolonged storage:

1. remove the machine from the tractor.
2. Wash the Green-Rite carefully, especially the hopper.
3. Inspect the Green-Rite and replace worn or damaged parts.
4. Tighten all hardware¹⁶.
5. Grease all areas indicated under maintenance.
6. If the machine is not supplied with the optional gauge wheels or front roller, lower the stand and pin in its lowest position (**see fig. 13**).
7. Hang the tractor end of driveline in the storage hook (**see fig. 11**).
8. Cover the Green-Rite from the elements in order to have it in perfect condition for the start of the next season.

¹⁶ See table 4, page 32.

6 - TROUBLESHOOTING



WARNING: be sure tractor engine is off, parking brake is locked, and key is removed before making any adjustments.

PROBLEM	POSSIBLE CAUSE	SOLUTION
Machine makes intermitting clicking noise.	Loose blade bolts. Gearbox gears or chain damaged.	<i>Tighten blade bolts. Replace damaged gears or chain.</i>
PTO vibrates.	Worn cross & bearings. Driveline at too great of an angle. Wrappings around rotor shaft.	<i>Replace worn cross and bearings. Machine working too high and the driveline at too much of an angle. Check for wrappings on rotor shaft.</i>
Gearbox noise is noticeable and constant.	Oil level low. Worn Gears.	<i>This can be normal on a new machine until it has been run in. Check oil level. Replace worn gears.</i>
Blades stop turning but PTO, gearbox and hexshaft are.	Broken drive chain.	<i>Remove chain case and check for broken connector link.</i>
PTO turning but not blades.	Slip clutch slipping.	<i>Adjust slip clutch or replace discs.</i>
Machine skips and leaves crop residue.	Worn blades. Slip Clutch slipping. Ground speed too fast.	<i>Check for badly worn blades. If worn down to tip, overlap will be lost and cutting will deteriorate. Replace worn blades. If slip clutch is used, check performance. Reduce ground speed.</i>
Machine smells hot or begins to smoke.	Wrappings around rotor. Gearbox oil low. Slip clutch slipping.	<i>Can be caused by friction from trash heavily wrapped around bearing protection covers. Remove trash immediately, as damage to bearing could result. Check oil level in gearbox and lubricant on chain. Check slip clutch if fitted. Adjust if needed.</i>
Oil leak from gearbox.	Oil seal damaged. Gearbox overfilled.	<i>Replace oil seal. Remove excess oil.</i>

7 - PRE-DELIVERY CHECKLIST

To the dealer: inspect the machine thoroughly after assembly to assure it is functioning properly before delivering it to the customer. The following checklist is a reminder of points to cover. Check off each item as it is found satisfactory or after proper adjustment is made.

- Gearbox oil level.
- Guards and shields properly fastened.
- Lubrication of grease fittings.
- All hardware properly tightened.
- All decals properly located and readable (**see fig. 2**).
- Blades properly installed and blade bolts & nuts tightened.
- Overall condition (touch up scratches, clean and polish).
- Test run, check for excessive vibration or overheating of bearings.
- Operator's Manual.

Review the operator's manual with the customer. Explain the following:

- Warranty.
- Safe operation and service.
- Correct machine installation and operation.
- Daily and periodic lubrication, maintenance and inspections.
- Troubleshooting.
- Operational procedures and storage.
- Parts and service.
- Remove and fill out the Delivery and Warranty Registration form.
- Give customer the operator's manual and encourage the customer to read the manual carefully.

IMPORTANT: warranty is not valid unless Delivery and Warranty Registration Form in operator's manual is completed in detail and mailed to the Company.

Model Number: _____

Serial Number: _____

Delivery Date: _____

Dealer's Signature: _____